

Schlumberger

Instruments Division

Schlumberger Technologies GmbH  
8000 München 46, Ingolstädter Straße 67 a, Postfach 46 07 29  
Telefon 0 89/3 18 89-0, Telefax 0 89/31 88 91 60, Telex 5 215 015 smg d

Communication Test Set

# STABILOCK 4031

Service Manual

Valid for series L188-L488

## LIST OF CONTENTS

Register	Name	Drawing no.
<b>A</b>	Code list of manufacturers	
<b>B</b>	<b>OVERALL UNIT</b>	
	Block diagram	108 800 B
	RF cabling	201 231 S
	RF motherboard	361 135 S
	<i>AF Motherboard</i>	361 136 S
	Panelling	108 801
	Location of stages	201 231
	Location of cables	202 231
	Assembly design	361 135
		361 136
	Electrical parts lists	201 231 Sa
		202 231 Sa
		361 135 Sa
		361 136 Sa
<b>CD</b>	<b>POWER SUPPLY</b>	
	Circuit diagram	204 031 S
	Assembly design	204 031 LP 1
		204 031 LP 2
	Electrical parts lists	204 031 Sa 1-28
<b>E</b>	<b>MODULATION GENERATOR A</b>	
	Functional description	208 029 F
	Alignment instructions	208 029 A
	Circuit diagram	208 029 S
	Assembly design	208 029
	Electrical parts list	208 029 Sa
	<b>MODULATION GENERATOR B</b>	
	Functional description	208 032 F
	Alignment instructions	208 032 A
	Circuit diagram	208 032 S
	Assembly design	208 032
	Electrical parts list	208 032 Sa

Register	Name	Drawing no.		
<b>F</b>	<b>AF DETECTOR</b>			
	Functional description	209 031 F		
	Alignment instructions	209 031 A		
	Circuit diagram	209 031 S		
	Assembly design	361 407		
		361 408		
		361 483		
	Electrical parts lists	209 031 Sa		
		361 407 Sa		
		361 408 Sa		
		361 483 Sa		
		<b>10-MHz REFERENCE CRYSTAL</b>		
		Functional description	214 031 F	
		Alignment instructions	214 031 A	
		Circuit diagram	214 031 S	
		Assembly diagram	361 419	
		Electrical parts lists	214 031 Sa	
			361 419 Sa	
		<b>G</b>	<b>DECADE SYNTHESIZER</b>	
			Functional description	210 041 F
Alignment instructions			210 041 A	
Circuit diagram	210 041 S			
Assembly diagram	361 403			
	361 445			
	361 446			
	361 447			
	361 448			
	361 449			
Electrical parts lists	210 041 Sa			
	361 403 Sa			
	361 445 Sa			
	361 446 Sa			
	361 447 Sa			
	361 449 Sa			

Register	Name	Drawing no.
<b>H</b>	<b>UHF SYNTHESIZER</b>	
	Functional description	213 041 F
	Alignment instructions	213 041 A
	Block diagram	213 041 B
	Circuit diagram	213 041 S
	Assembly diagram	361 401
		361 435
		361 436
		361 437
		361 438
		361 439
	Electrical parts lists	213 041 Sa
		361 435 Sa
		361 436 Sa
		361 437 Sa
		361 438 Sa
		361 439 Sa
<b>IJ</b>	<b>FM MODULATOR</b>	
	Functional description	217 031 F
	Alignment instructions	217 031 A
	Circuit diagram	217 031 S
	Assembly diagram	361 402
		361 455
		361 456
		361 457
	Electrical parts lists	217 031 Sa
		361 402 Sa
		361 455 Sa
		361 456 Sa
		361 457 Sa
<b>K</b>	<b>ATTENUATOR</b>	
	Functional description	226 031 F
	Circuit diagram	226 031 S
	Assembly diagram	361 171
		361 420
	Electrical parts lists	226 031 Sa
		361 171 Sa
		361 420 Sa



Register	Name	Drawing no.
<b>L</b>	<b>CONTROL PANEL</b>	
	Functional description	227 031 F
	Alignment instructions	227 031 A
	Circuit diagram	227 031 S
	Location of circuit boards and adjusters	227 031
	Assembly diagram	361 421
		361 422
	Electrical parts lists	227 031 Sa
		361 421 Sa
		361 422 Sa
<b>M</b>	<b>DUPLEX FM DEMODULATOR</b>	
	Functional description	229 033 F
	Alignment instructions	229 033 A
	Circuit diagram	229 033 S
	Assembly diagram	361 440
		361 464
		361 482
		361 383
	Electrical parts lists	229 033 Sa
		361 440 Sa
		361 464 Sa
		361 482 Sa
		361 383 Sa
<b>NO</b>	<b>RF POWER METER</b>	
	Functional description	229 031 F
	Alignment instructions	229 031 A
	Circuit diagram	229 031 S
	Location plan	229 031
		300 675
	Assembly diagram	361 424
	Electrical parts lists	229 031 Sa
		361 424 Sa
<b>PQ</b>		
<b>R</b>	<b>IF UNIT</b>	
	Functional description	229 032 F
	Alignment instructions	229 032 A
	Circuit diagram	229 032 S
	Assembly diagram	229 032
	Electrical parts list	229 032 Sa

Register	Name	Drawing no.
<b>S</b>	<b>OUTPUT UNIT</b>	
	Functional description	230 031 F
	Alignment instructions	230 031 A
	Block diagram	230 031 B
	Circuit diagram	230 031 S
	Assembly diagram	361 400
		361 425
		361 426
		361 427
	Electrical parts lists	230 031 Sa
		361 400 Sa
		361 425 Sa
		361 426 Sa
		361 427 Sa
<b>SCH</b>	<b>EXTERNAL MEMORY</b>	
	Functional description	235 032 F
	Circuit diagram	235 032 S
	Assembly diagram	361 433
	Electrical parts list	361 433 Sa
<b>St</b>	<b>MONITOR CONTROL</b>	
	Functional description	236 032 F
	Alignment instructions	236 032 A
	Circuit diagram	236 032 S
	Assembly diagram	236 032
		361 412
	Electrical parts lists	236 032 Sa
		361 412 Sa
	<b>MONITOR</b>	
	Functional description	239 003 F
	Alignment instructions	239 003 A
	Circuit diagram	239 003 S
	Assembly diagram	361 461
	Electrical parts lists	239 003 Sa
		361 461 Sa

Register	Name	Drawing no.
<b>TV</b>	<b>DATA MODULE</b>	
	Functional description	236 034 F
	Alignment instructions	236 034 A
	Circuit diagram	236 034 S
	Assembly diagram	236 034
	Electrical parts list	236 034 Sa
	<b>CONTROL INTERFACE A/B/C</b>	
	Functional description	236 035/36/37 F
	Alignment instructions	236 035/36/37 A
	Circuit diagram	236 035 S
		236 036 S
		236 037 S
	Assembly diagram	236 035
		236 036
		236 037
	Electrical parts lists	236 035 Sa
		236 036 Sa
		236 037 Sa
	<b>RF COUNTER</b>	
	Functional description	237 032 F
	Alignment instructions	237 032 A
	Circuit diagram	237 032 S
	Assembly diagram	237 032
		361 470
	Electrical parts lists	237 032 Sa
		361 470 Sa

Register	Name	Drawing no.
<b>W</b>	<b><u>OPTIONS</u></b>	
	<b>OPTION CARD</b>	
	Functional description	236 033 F
	Alignment instructions	236 033 A
	Circuit diagram	236 033 S
	Assembly diagram	236 033
		361 411
	Electrical parts lists	236 033 Sa
		361 411 Sa
	<b>C-NET EXPANDER</b>	
	Functional description	248 116 F
	Alignment instructions	248 116 A
	Circuit diagram	248 116 S
	Assembly diagram	248 116
	Electrical parts list	248 116 Sa
	<b>DTMF MODULE</b>	
	Functional description	248 171 F
	Alignment instructions	248 171 A
	Circuit diagram	248 171 S
	Assembly diagram	248 171
	Electrical parts list	248 171 Sa
	<b>DC/VA METER</b>	
	Functional description	248 172 F
	Alignment instructions	248 172 A
	Circuit diagram	248 172 S
	Assembly diagram	248 172
		361 476
	Electrical parts lists	248 172 Sa
		361 476 Sa
	<b>300-Hz LOWPASS FILTER</b>	
	Functional description	248 174 F
	Alignment instructions	248 174 A
	Circuit diagram	248 174 S
	Assembly diagram	248 174
	Electrical parts list	248 174 Sa

Register	Name	Drawing no.
<b>W</b>		
<b>4-kHz BANDPASS FILTER</b>		
	Functional description	248 175 F
	Alignment instructions	248 175 A
	Circuit diagram	248 175 S
	Assembly diagram	248 175
	Electrical parts list	248 175 Sa
<b>6-kHz Bandpass Filter</b>		
	Functional description	248 176 F
	Alignment instructions	248 176 A
	Circuit diagram	248 176 S
	Assembly diagram	248 176
	Electrical parts list	248 176 Sa
<b>VARIABLE NOTCH FILTER 200-600 Hz</b>		
	Functional description	248 179 F
	Alignment instructions	248 179 A
	Circuit diagram	248 179 S
	Assembly diagram	248 179
	Electrical parts list	248 179 Sa
<b>3-kHz LOWPASS FILTER</b>		
	Functional description	248 186 F
	Alignment instructions	248 186 A
	Circuit diagram	248 186 S
	Assembly diagram	248 186
	Electrical parts list	248 186 Sa
<b>300-Hz HIGHPASS FILTER</b>		
	Functional description	248 199 F
	Alignment instructions	248 199 A
	Circuit diagram	248 199 S
	Assembly diagram	248 199
	Electrical parts list	248 199 Sa

Register	Name	Drawing no.
<b>XZ</b>	<b>STABITEXTER</b>	
	Functional description	248 181 F
	Alignment instructions	248 181 A
	Circuit diagram	248 181 S
	Assembly diagram	361 525
	Electrical parts list	361 525 Sa
	<b>HOST COMPUTER</b>	
	Functional description	250 031 F
	Circuit diagram	250 031 S
	Assembly diagram	250 031
	Electrical parts list	250 031 Sa
	<b>SLAVE COMPUTER</b>	
	Functional description	250 032 F
	Alignment instructions	250 032 A
	Circuit diagram	250 032 S
	Assembly diagram	250 032
	Electrical parts list	250 032 Sa



CODE LIST OF MANUFACTURERS - HERSTELLERVERZEICHNIS

Actual Code Aktuelle Bezeichg.	Old Code Alte Bez.	Manufacturers Hersteller	Our Suppliers Unsere Lieferanten
AEG		AEG	AEG Telefunken, Arnulfstr. 205, D-8000 München 19
ALB		Albrecht	G. Albrecht, Gartenstr. 8, CH-6331 Hünenberg
ALAN		Alan Industries	microscan GmbH, Schloßgartenweg 1, D-8045 Ismaning
ALLEN		Allen-Bradley	Allen-Bradley GmbH, Kochstr. 49, D-4150 Krefeld
AMD		Advanced Micro Devices	Advanced Micro Devices, Herzog-Heinrich-Str. 3, D-8000 München 2
AMP		AMP Deutschland	AMP Deutschland GmbH, Amperestr. 7-11, D-6070 Lange
AMPH		Amphenol	Amphenol Europa GmbH, Grünwalder Weg 30, D-8024 Deisenhofen
ANAL		Analog Dev.Inc.	Analog Devices GmbH, Mozartstr. 17, D-8000 München
ANZ		anzac	Interelectronic KG, Hochbrückenstr. 10, D-8000 München 2
ASSM		Assmann	Assmann + Söhne, Am Ramsberg 27, D-5880 Lüdenscheid
AUG		Augat	Neumüller GmbH, Eschenstr. 2, D-8021 Taufkirchen
AVAN		Avantek	Telemeter Electronic GmbH, Posthof 4, D-8850 Donauwörth
BECK		Beckman	Beckman Instruments GmbH, Frankfurter Ring 115, D-8000 München 45
BERT		Bertram	Bertram, Planegger Str. 125, D-8000 München 60
BONN		Bonn	Dipl.-Ing. H. Bonn, Mariahilfplatz 2, D-8000 München 90
BOSCH	BO	Bosch	Robert Bosch GmbH, Bregenzer Str. 12, D-7000 Stuttgart-Feuerbach
BOUR		Bourrghs	A. Neye-Enatechnik GmbH, Maria-Theresia-Str. 6 D-8000 München 80
BUR		Burster	B.Präzisionstechnik Hubert Burster, Talstrasse 7, D-7562 Gernsbach
CAN		Cannon	Cannon Electric GmbH, Poststr.17, D-7056 Weinstadt
C-ASS		Circuit-Assembly Corp. (CA)	Seltronics GmbH, Hermannstr. 4, D-8014 Neubiberg
CELD		Celduc	Componenta, Rudolf-Diesel-Str.18, D-8012 Ottobrunn
CHERRY		Cherry	Cherry-Mikroschalter GmbH, Postfach 2340, D-8580 Bayreuth 2
CIRC		Circuit Assembly	Neumüller GmbH, Eschenstr. 2, D-8021 Taufkirchen
CLAB		Centralab	Bodamer GmbH, Südl. Münchner Str. 24 a, D-8022 Grünwald
CLAIR		Clairex Electron.	Ginsbury Electronic GmbH, Ahornstr. 10, D-8012 Ottobrunn
COM		Comatel	Comatel GmbH, Würbenthalerstr.2, D-7032 Sindelfingen
CONT		Contraves	Contraves, Schaffhausener Str.580, CH-8034 Zürich
CORC		Corcom	Tekelec-Airtronic GmbH, Nussbaumstr. 4, D-8000 München 2
COY		Mc Coy	Ginsbury Electronic GmbH, Ahornstr. 10, D-8012 Ottobrunn
CSF		Thomson CSF	Thomson CSF GmbH, Fallstr. 42, D-8000 München 70
CTS	KNI	CTS Knights Inc.	CTS Knights Inc., Sandwich, Illinois 60548, U.S.A.
DALE		Dale	Dale Electronics GmbH, Falkweg 51, D-8000 München 60
DEC		Digital Equipment	Digital Equipment, Arabellastr. 30, D-8000 München 81
DELE		Delevan	Amphenol Europa GmbH, Grünwalder Weg 30, D-8024 Deisenhofen
DIEL		Dielektra	Dielektra AG, Kaiserstr. 127, D-5050 Porz

Actual Code Aktuelle Bezeichg.	Old Code Alte Bez.	Manufacturers Hersteller	Our Suppliers Unsere Lieferanten
DITRA		Ditratherm	Ernst Roederstein, Ludmillastr. 23/25, D-8300 Landshut
DRAL	DRALOR	Draloric (former Dralowid)	Draloric Electronic GmbH, Postfach 1180, D-8672 Selb (resistors, capacitors) Draloric, Kaiserstr.21, D-5050 Porz (potentiom.)
DUNK		Dunker	Christian Dunker, Postfach 13, D-7823 Bonndorf
EBB		EBB	EBB, Körnerstr. 19-21, D-1000 Berlin 30
EBE		Elektro-Bauelem.	EBE Elektro-Bauelemente GmbH, D-7021 Stetten/Filder
ECI		MECA	Electronic Components + Instruments, Oskar- Maria-Graf-Ring 17, D-8000 München 83
EDAK		EDAK	EDAK Metall,-Geräte u. Apparatebau, Postfach, CH-8201 Schaffhausen
EDI		Electronic Devices Inc.	Indeg GmbH, Kemmatenstr. 66, D-8000 München 19
EHW		E.H.W.	Elektro- Heiz- u. Widerstands-GmbH, D-5750 Minden/Sauerland
ELCO		Elco	Deutsche Elco GmbH, Alter Weg 1, D-5241 Nieder- dreisbach
ELEC		Electronic GmbH	Electronic GmbH, Münchner Str.51, D-8025 Unterhaching
ELF		elfein	E.Sommer Elektronik GmbH, Jahnstr. 43, D-6000 Frankfurt/Main
ELMA		ELMA Electronic	ELMA Electronic AG, Am Schönaich, CH-8620 Wetzikon
EMC		EMC Technology	E. Parzich, Karwendelstr. 8, D-8911 Pürgen
ERIE		ERIE	ERIE Elektronik GmbH, Postfach 20, D-8500 Nürnberg 52
ERNI		ERNI	ERNI-Elektroapparate, Seestr.9, D-7321 Adelberg
ETTING		Ettinger	E.Ettinger, Florian-Geyer-Str.1, D-8000 München 70
FAIR		Fairchild	Electronic 2000 Vertriebs-GmbH, Neumarkter Str.75, D-8000 München 80
FAUL		Faulhaber	Dr. F.Faulhaber, Postfach 46, D-7036 Schönaich
FERN		dto. -->	Fernsteuergeräte Kurt Oelsch KG, Jahnstr. 68-72, D-1000 Berlin 11
FISCH		Fischer Elektron.	Fischer Elektronik oHG, Postfach 2304, D-5880 Lüdenscheid
FRÖ		Frötherm	Frötherm, Glonnerstr. 12, D-8011 Oberpframmern
GARD		Gardners Transf.	Gardners Transformers Ltd. Christchurch/Hampshire BH 23/3 PN, England
GENRAD G + H	GERA	General Radio Grote + Hartmann	General Radio Comp., Helenastr.3, CH-8034 Zürich Grote + Hartmann, Otto-Hahn-Str. 7, D-5600 Wuppertal 21
GHIEL GI	GEIN	Ghielmetti General Instrum.	Ghielmetti GmbH, Siemensstr.5, D-6392 Neu-Anspach 1 General Instrument Deutschland GmbH, Neumarkter Str. 61, D-8000 München 80
GOSS GOW		Gossen Gowanda	Gossen GmbH, Nägelsbachstr. 25, D-8520 Erlangen A. Roßmann electronic-Vertrieb, Keltenstr. 13, D-8911 Windach
GRU GRUN GÜN		Grundmann Gruner Günther	H. Grundmann, Strassbergerstr. 28, D-8000 München 40 W.Gruner KG, Postfach 16, D-7209 Wehingen W. Günther GmbH, Postfach 740, D-8500 Nürnberg 1
HAM		Hamlin	Amphenol Europa GmbH, Grünwalder Weg 30, D-8024 Deisenhofen
HAR		Harris	Kontron Elektronik GmbH, Breslauer Str. 2, D-8057 Eching
HARM		Hartmann	Eduard Hartmann, D-7061 Schornbach



Actual Code Aktuelle Bezeichg.	Old Code Alte Bez.	Manufacturers Hersteller	Our Suppliers Unsere Lieferanten
HART H + B	HABR	Harting Hartmann + Braun	W. Harting, Postfach 106, D-4992 Espelkamp-Mittwald Hartmann u. Braun AG, Seeligerstr. 10, D-8000 München 81
HEIL HELL HERM HIR HOLZ		Otto Heil oHG Hellermann (Hermeyer) Hirschmann Holzinger	Otto Heil oHG, Postfach 446, D-6370 Oberursel P.Hellermann GmbH, Siemensstr.5, D-2080 Pinneberg no more existing/nicht mehr existent(see Günther) R.Hirschmann, Ottilienstr.19, D-7300 Esslingen Max Holzinger + Co. GmbH, Woelkestr. 4, D-8069 Schweitenkirchen
HP	HEPA	Hewlett Packard	Hewlett Packard, Berliner Str. 117, D-6000 Frankfurt-Niedereschbach 56
HUG HYBRID		Hughes Hybrid Systems C.	Hughes, Riverton, New Jersey, U.S.A. Hybrid GmbH, Luisenplatz 4, D-6100 Darmstadt
INDEG INTER INTERS ISO ITT		Indeg Intertec Intersil Isophon Intermetall(diode (switches)	Indeg GmbH, Kemnatenstr. 66, D-8000 München 19 Kontron Elektr.GmbH, Breslauerstr.2,D-8057 Eching Spezial-Electronic, Ortlerstr.8, D-8000 München 70 Radio Rim, Bayerstr. 25, D-8000 München 2 Intermetall GmbH, Postfach 840, D-7800 Freiburg Intermetall Gmbn, Postfach 2907,D-8500 Nürnberg 1
JAHRE JAU JEAN JERM	JAHR	Jahre Jautz Jeanrenaud Jermyn	Richard Jahre, Lützowstr. 90, D-1000 Berlin 30 Karl Jautz, Urbanstr. 34, D-7310 Plochingen Usine Jeanrenaud, 42 Ave. de Gray, F-39 Dôle Jermyn-Industries, Schulstr.36, D-6277 Camberg
KIE KLAR		Kienzle Klar+Beilschmidt	Kienzle GmbH, Führichstr. 70, D-8000 München 80 Klar u. Beilschmidt, Landshuter Str. 52, D-8300 Landshut
KLAS		Klasing	Hermann Klasing u. Co., Ettinger Str. 36, D-8070 Ingolstadt see CTS
KNI KNITT KNÜRR KOCH KORD KROM		Knitter Knürr Koch Kordes Kromberg u. Schubert	knitter-switch, Postfach 8, D-8011 Baldham Knürr KG, Ampfingstr. 27, D-8000 München 80 Koch Elektronik KG, Postfach 1350,D-3257 Springe 1 Norbert Kordes, Elektr.Fabrik, D-3419 Sohlingen Kromberg u. Schubert, Postfach 220 206, 5600 Wuppertal-Langerfeld
KVG	KVN	Kristall-Verarb.	Kristallverarbeitung GmbH, Postfach 7, D-6924 Neckarbischofsheim
LAM LEON		Lambda Leonische Drahtw.	Astronic, Winzererstr. 47 d, D-8000 München 40 Leonische Drahtwerte AG, Marienstr. 7, D-8500 Nürnberg
LITRON LORCH		Litronix Lorch	Omni-Ray GmbH, Ritzbruch 41, D-4054 Nettetal 1 Auriema Distribution GmbH, Uhdestr. 33, D-7100 Heilbronn
LUMB		Lumberg	Karl Lumberg KG, Postfach 1170,D-5885 Schalkmühle 1
MACH MARQ MA SCHUH		Machate Marquardt Magnet-Schultz	Ing.J. Machate, Asslkofenerstr.32, D-8017 Ebersberg Marquardt KG, Schalterfabrik, D-7201 Rietheim Magnet-Schultz GmbH, Postfach 1940, D-8940 Memmingen
MATSU		Matsushita Elec. Works Ltd.	SDS Elektro GmbH, Fichtenstr.5, D-8024 Deisenhofen
MATSUO		Matsuo	Spezial-Electronic, Hermann-Lingg Str. 16, D-8000 München 2

Actual Code Aktuelle Bezeichg.	Old Code Alte Bez.	Manufacturers Hersteller	Our Suppliers Unsere Lieferanten
MCL		Mini Circuits Lab.	Industrial Electronics GmbH, Klüberstr. 14, D-6000 Frankfurt/Main
MCMU		McMurdo Instr.Ltd.	The McMurdo Instruments Ltd., Ashtead, Surrey, England
MECA		MECA	ECI GmbH, Hochbrückenstr. 10, D-8000 München 2
MEGA		Megatron	Megatron EK, Hermann-Oberth-Str.7,D-8011 Putzbrunn
MEM		MEM microelectron.	Unilab Electronics, Hermann-Oberth-Str.7, "
MEN		Mentor	Mentor, Ing.Dr. Paul Mozar, Postfach 15, D-4006 Erkrath-Unterbach
MENZ		Menzel	Dr. Oscar Menzel Nachf., Kronwinklerstr. 36, D-8000 München 60
METRO		Metrofunk	Metrofunk, Schmidt-Ott-Str.5a,D-1000 Berlin 41
MIAL		MIAL	MIAL Elektro.Bauelemente GmbH, Landbergerstr.20, D-8000 München 2
MIC		Micro Associates	Micro Associates Ltd., Cradeck Road, Luton/ Bedfordshire, England
MICRO		Micropac	Nucletron GmbH, Gärtnerstr.60,D-8000 München 50
MILT		Milton	Milton Ross Co. Ltd., 14 New Road Warford, Herfordshire, England
MINL		Minleit	Minleit GmbH, Haagenerstr. 20, D-7850 Lörrach
MON		Monsanto	Alfred Neye-Enatechnik, Schillerstr. 14, D-2085 Quickborn
MONOL		Monolithic Memories	Neumüller GmbH, Eschenstr.2, D-8021 Taufkirchen
MOT		Motorola	Motorola Semiconductor Prod. Inc., Phoenix Arizona 85008, U.S.A. or: Motorola Halbleiter GmbH, Fiedlerstr. 5, D-8000 München 71
NARDA		Narda Microwave	Rohde + Schwarz GmbH, Mühldorfstr. 15, D-8000 München 80
NARD		Nardeux	Nardeux, Bête Postale No. 109, F-37600 Loches
NEC		NEC	Microscan GmbH, Schlossgartenweg 1, D-8045 Ismaning
NEO		Neosid	Neosid-Pemetzrieder GmbH, Langenscheider Weg 26, D-5894 Halver
NEUB		Neuberger	Josef Neuberger Messinstrumente KG, Steinerstr.16, D-8000 München 70
NIEB		Niebling	Niebling, Seeshaupterstr. 56, D-8122 Penzberg
NS	NASEM	National Semicond.	Sasco GmbH, Hermann-Oberth-Str. 16, D-8011 Putzbrunn or: Neumüller GmbH, Eschenstr. 2, D-8021 Taufkirchen
OHMIC		Ohmic Bourns	Bourns AG, Eberhardstr. 63, D-7000 Stuttgart 5
OPCOA		Opcoa	Neumüller GmbH, Eschenstr. 2, D-8021 Taufkirchen
PAND		Panduit	Panduit GmbH, Postfach 1923, D-6380 Bad Homburg 6
PAPST		Papst	Papst Motoren KG, Postfach 35,D-7742 St.Georgen
PHIL		Philips	Philips, Röntgenstr. 22, D-2000 Hamburg 63
PIEZO		Piezo Technology	Ginsburg Electronic GmbH, Ahornstr. 10, D-8012 Ottobrunn
PLES		Plessey	Plessey GmbH, Altheimer Eck 10, D-8000 München 2
PREH		Preh	Preh Vertriebs-GmbH, Postfach 1540, D-8740 Bad Neustadt
QUAK		Quarzkeramik	Quarzkeramik GmbH, Gautinger Str. 23, D-8031 Stockdorf
QUAT		Quarztechnik	Quarztechnik Willi Müller, Metzener Str. 24-26, D-5568 Daun

Actual Code Aktuelle Bezeichg.	Old Code Alte Bez.	Manufacturers Hersteller	Our Suppliers Unsere Lieferanten
RAFI		Rafi	Rafi GmbH + Co. Raimund Finsterhölzl, Postfach 2060, D-7980 Ravensburg
RAYT		Raytheon	PAN Electronic, Schlesierstr.4, D-8021 Taufkirchen
RCA		Radio Corp.of Amer.	Radio Corp.of America, Harrison, N.J.07029, USA
REFE		Rhein.Feindraht...	Rheinische Feindraht Industrie Dr.Ing. Schildbach, D-5281 Eckenhausen
REL		Reliability	Tisco GmbH, Arabellastr. 13-15, D-8000 München 81
RELIC		Relcom	Watkins Johnson International, Münchnerstr. 17, D-8031 Planegg
RES		Resista	Resista GmbH, Ludmillastr. 23-25, D-8300 Landshut
RIG		(Rosenthal-Isolatoren)	no longer existing, existiert nicht mehr
RUF	RUW	Ruf oHG	Now: Draloric Electronic GmbH, Postfach 1180, D-8672 Selb Sasco GmbH, Hermann-Oberth-Str. 16, D-8011 Putzbrunn or: Ruf oHG, D-8011 Höhenkirchen
RUS		Ruhstrat	Ruhstrat KG, D-3401 Lenglern
RYA		Ryam	ELMA Electronic AG, Am Schönaich, CH-8620 Wetzikon
SACO		Sasco	Sasco GmbH, Hermann-Oberth-Str. 16, D-8011 Putzbrunn
SASS		Sasse	Dr. E. Sasse KG, Mühlenstr. 4, D-8540 Schwabach
SCHB		Schalbau	Schalbau GmbH, Hohenwaldeckstr. 1, D-8000 München 90
SCHL		Schlumberger	Schlumberger Meßgeräte GmbH, Ingolstädter Str. 67a D-8000 München 46
SCHÖ		Schöllner	Schöllner + Co., Dreieichstr.6, D-6082 Mörfelden
SCHU		Schurter	H. Schurter AG, Werkhofstr. 8, CH-6002 Luzern
SCI		Semicond.Circuits	Astronic, Winzererstr. 47 d, D-8000 München 40
SCOTCH			see 3M
SDS		SDS	SDS-Elektro-GmbH, Fichtenstr.5, D-8024 Deisenhofen
SE		Spezial-Electronic	SE Spezial-Electronic KG, Oberauer Str. 15, D-8000 München 70
SEL	SAF	SEL	SEL-Kontakt-Bauelemente, Postfach 2907, D-8500 Nürnberg 2
SEMI		Semicon	Semicon International, Siegmundstr. 200, D-8500 Nürnberg 113
SGS		SGS	SGS Deutschland, Postfach 1269, D-8090 Wasserburg
SIG		Signetics	Valvo GmbH, Postfach 106 323, D-2000 Hamburg 1
SILI		Siliconix	Siliconix, Postfach 1340, D 7024 Bernhausen
SILIC		Silicon General	Neumüller GmbH, Eschenstr. 2, D-8021 Taufkirchen
SIV		Sivers Lab.	Philips, Röntgenstr. 22, D-2000 Hamburg 63
SOCA		Socapex	Thomsen CSF GmbH, Fallstr.42, D-8000 München 70
SOLIT		Solitron	Neumüller GmbH, Eschenstr. 2, D-8021 Taufkirchen
SONN		Sonnenschein	Sonnenschein GmbH, Postfach 1180, D-6470 Büdingen-Tiergarten
SOUR		Sourian	Sourian Elektronik GmbH, Heinrich-Hertz-Str. 1, D-4006 Erkrath-Unterbach
S u. H		Siemens u. Halske	Siemens AG, Richard-Strauss-Str. 76, D-8000 München 80
STEA		(Steatit-Magnesia)	no more existing/existiert nicht mehr
STET		Stettner	Now: Draloric, Kaiserstr. 21, D-5050 Porz
STGR		Standard grigsby	Stettner u. Co., Hersbrucker Str. 22, D-8560 Lauf
STO		Stocko	W. Günther GmbH, Postfach 740, D-8500 Nürnberg 1
SUHN		Suhner	Stocko Metallwarenfabrik, Postfach 81, D-5600 Wuppertal-Elberfeld
SYL		(Synvania GmbH)	Suhner u. Co. AG, CH-9100 Herisau
SYN		Synertek	Suhner GmbH, Postfach 900 660, D-8000 München 90 no more existing/existiert nicht mehr
			Astronic, Winzererstr. 47 d, D-8000 München 40

Actual Code Aktuelle Bezeichg.	Old Code Alte Bez.	Manufacturers Hersteller	Our Suppliers Unsere Lieferanten
TECK TEK TEKE		Teckentrup Tektronix Tekelec	Teckentrup KG, Wilhelmstr.28,D-5970 Plettenberg 1 Rohde + Schwarz, Mühlendorfstr.15,D-8000 München 80 Tekelec Airtronic GmbH, Nussbaumstr. 4, D-8000 München 2
TELC		telcom	telcom-funksysteme GmbH, Marktstr. 15, D-7540 Neuenburg 1
TELED TELEM		Teledyne Philbrick Telemeter	Teledyne Philbrick, Burgstr.6-8,D-6200 Wiesbaden Telemeter Electronic GmbH, Posthof 4, D-8850 Donauwörth
TELEQ		Telequarz	Telequarz GmbH, Landstr.13, D-6924 Neckarbischofsheim 2
TELON		Telonic Industries	Telonic Industries GmbH, Alte Heerstr. 91, D-5400 Koblenz
TEXSC TF THERM TI	TELE   TEX	Texscan Telefunken Thermalloy Texas Instruments	Texscan GmbH, Peschelanger 11,D-8000 München 83 Telefunken AG, Widenmayerstr. 19, " " 22 Neumüller GmbH, Eschenstr. 2, D-8021 Taufkirchen Texas Instruments Inc., P.O. Box 5012, Dallas, Texas 75222, U.S.A.
TOYCO TRA TRANSIT TRON TUCH		Toyco Traub Transitron Tronser	Grenz + Co.KG, Bülowstr. 27, D-8000 München 80 J. Traub oHG, St.Pauls-Platz 7,D-8000 München 2 PAN-Electronic, Schlesierstr.4,D-8021 Taufkirchen A.Tronser Apparatebau GmbH, D-7543 Engelsbrand 1 see Amphenol
VAC VAL VAR	VACU	Vacuumschmelze Valvo Varta	Vacuumschmelze GmbH,Postfach 109, D-6450 Hanau Valvo GmbH, Burchardstr. 19, D-2000 Hamburg 1 Varta GmbH, Nymphenburger Str. 128, D-8000 München 19
VARO VATE		Varo Vakuumentchnik	Indeg GmbH, Kemnatenstr. 66, D-8000 München 19 Vakuumentchnik GmbH, Fliessbachstr. 16, D-8520 Erlangen
VID		Videon	S.A.Videon, 95 rue d'Agnesseau,F-92 Boulogne sur Seine
VIT		Vitrohm	Deutsche Vitrohm GmbH + Co.KG, Siemensstr. 7-9 D-2080 Pinneberg
VOGT		Vogt	Vogt GmbH + Co.KG, D-8391 Erlau
WAKE		Wakefield	Wakefield Eng. Inc., Delta Division, Wakefield, Mass. 01880, U.S.A.
WEIG		Weigand	Weigand GmbH, Mittlere Schulstr. 4, D-8520 Erlangen
WEIN		Weinschel	Kontron Elektronik GmbH, Breslauerstr. 2, D-8057 Eching
WEST		Weston Instr.	Weston Instruments Inc., 614 Frelinghuysen Ave. Newark, N.J. 07114, U.S.A.
WJ WICK		Watkins-Jonson Wickmann	Watkins-Jonson. Manzinger Weg 7,D-8000 München 60 Componenta GmbH, Rudolf Diesel Str. 18, D-8012 Ottobrunn
ZELT		Zeltex	Knott Electronic GmbH, Benediktstr.1, D-8021 Hohenschäftlarn
ZENTRO		Zentro	Zentro Elektronik GmbH KG, Sandweg 20, D-7530 Pforzheim
3 M	SCOTCH	Minnesota Mining Manufacturing	Minnesota Mining Manuf. GmbH, Denningerstr. 25, D-8000 München 81

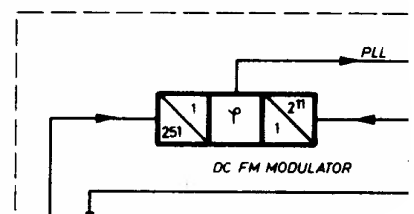
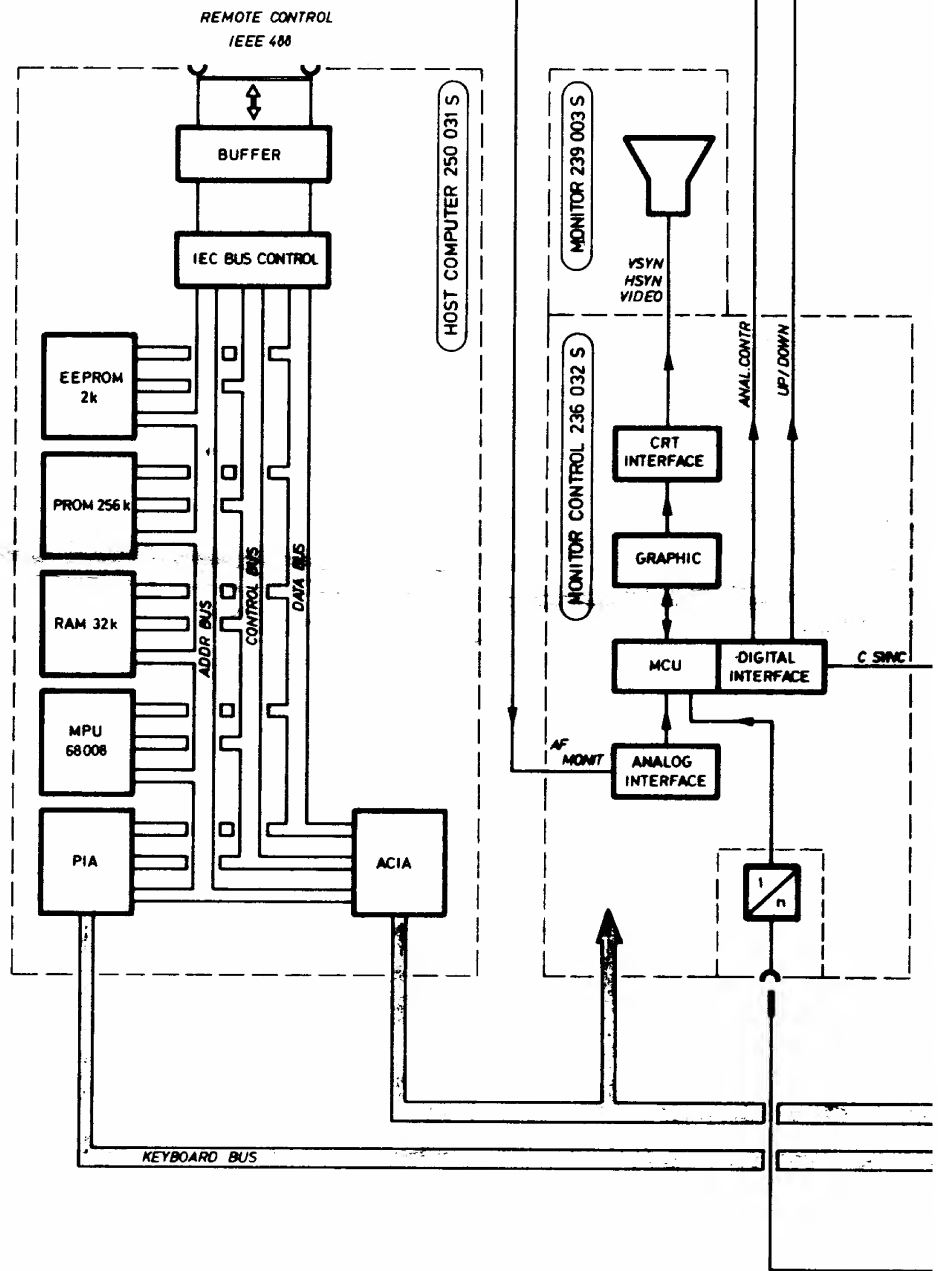

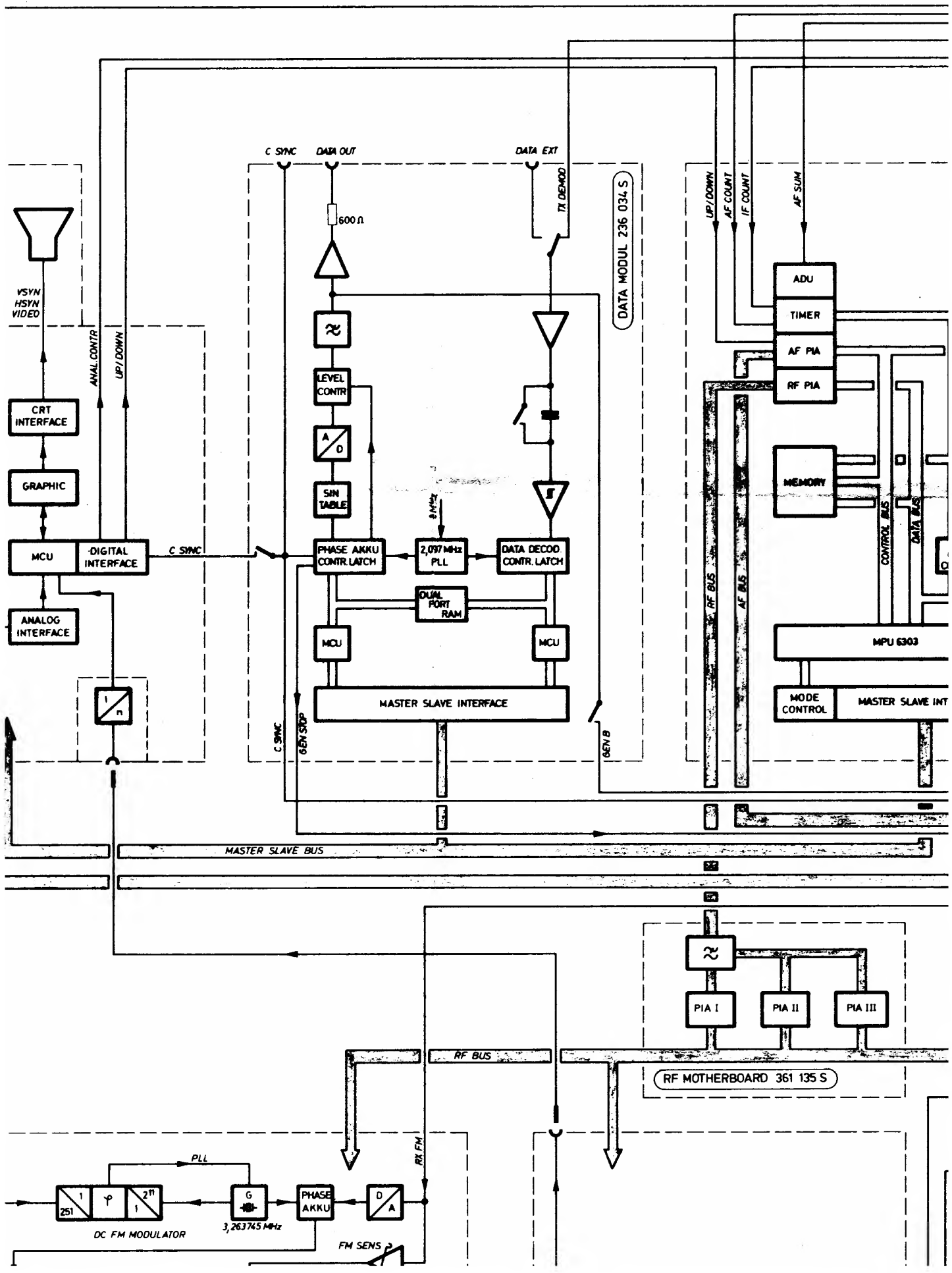

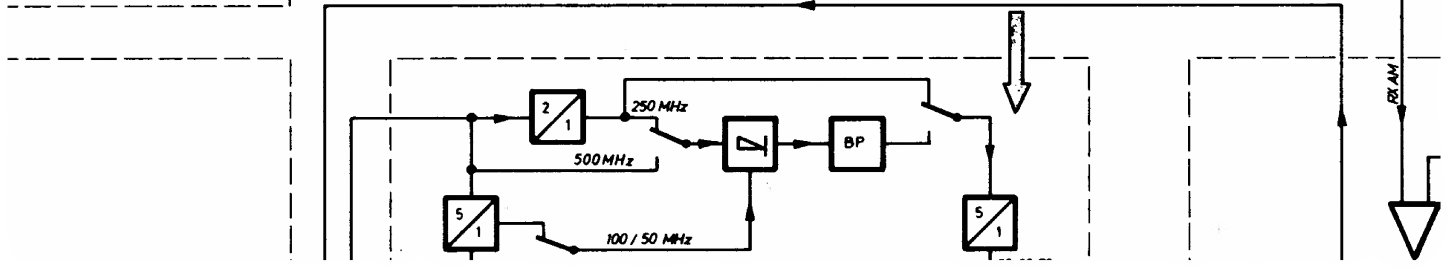
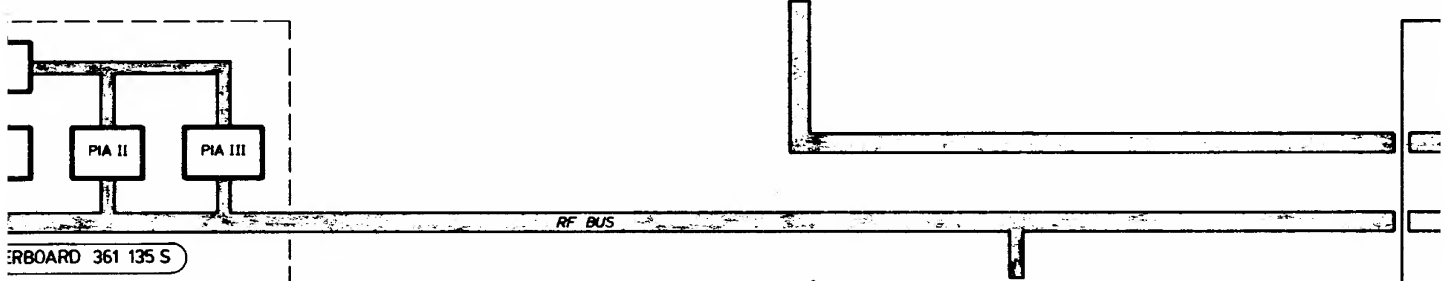
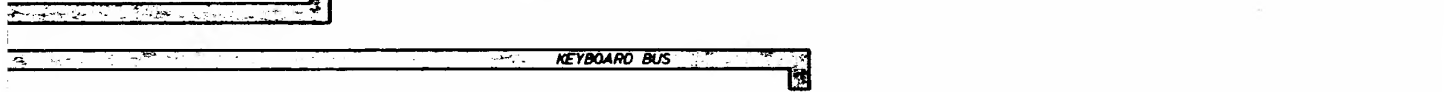
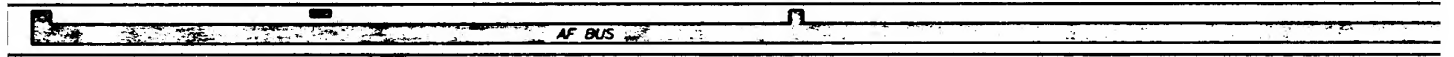
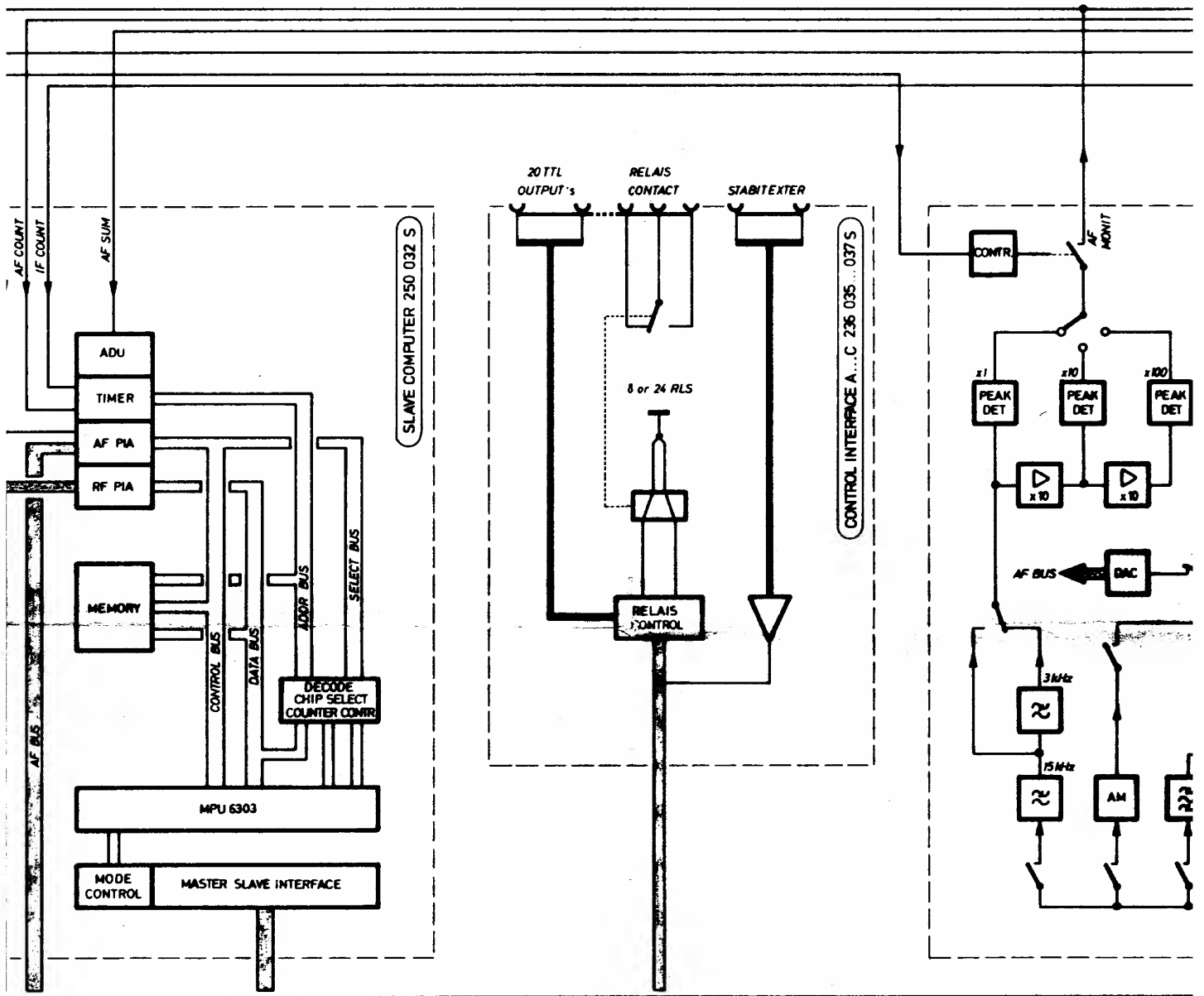

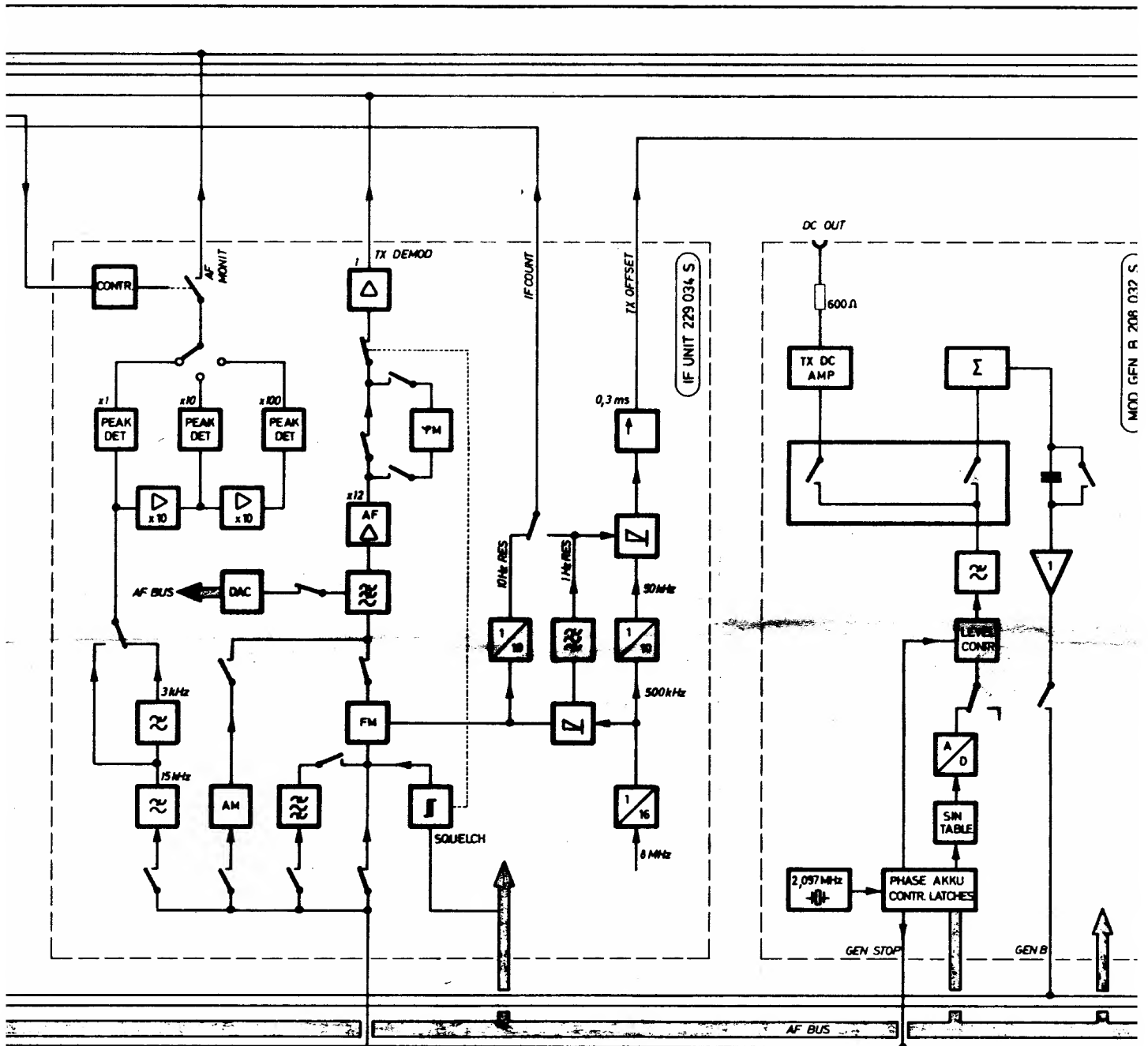

MOD GEN R 208 032 S

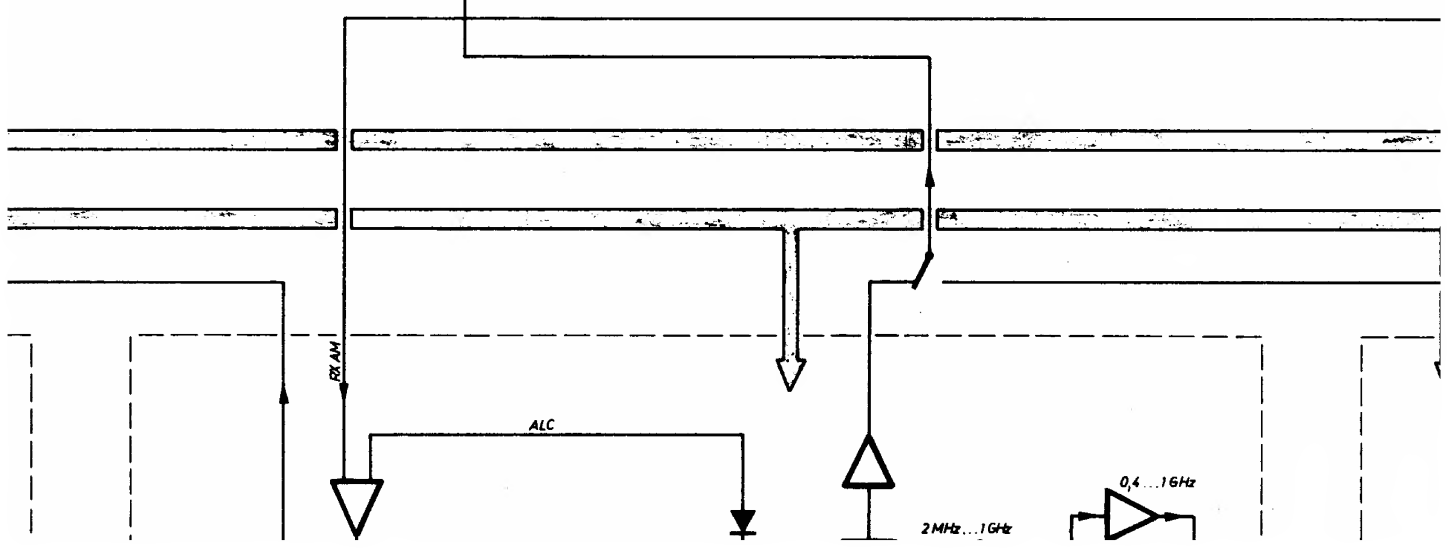



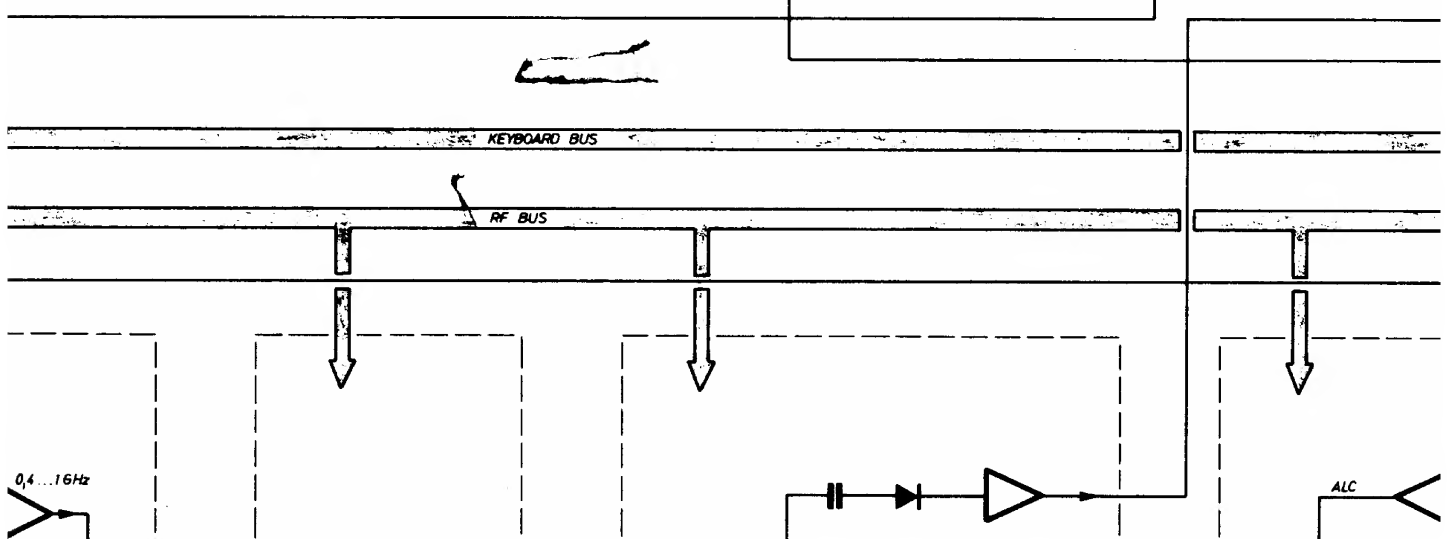
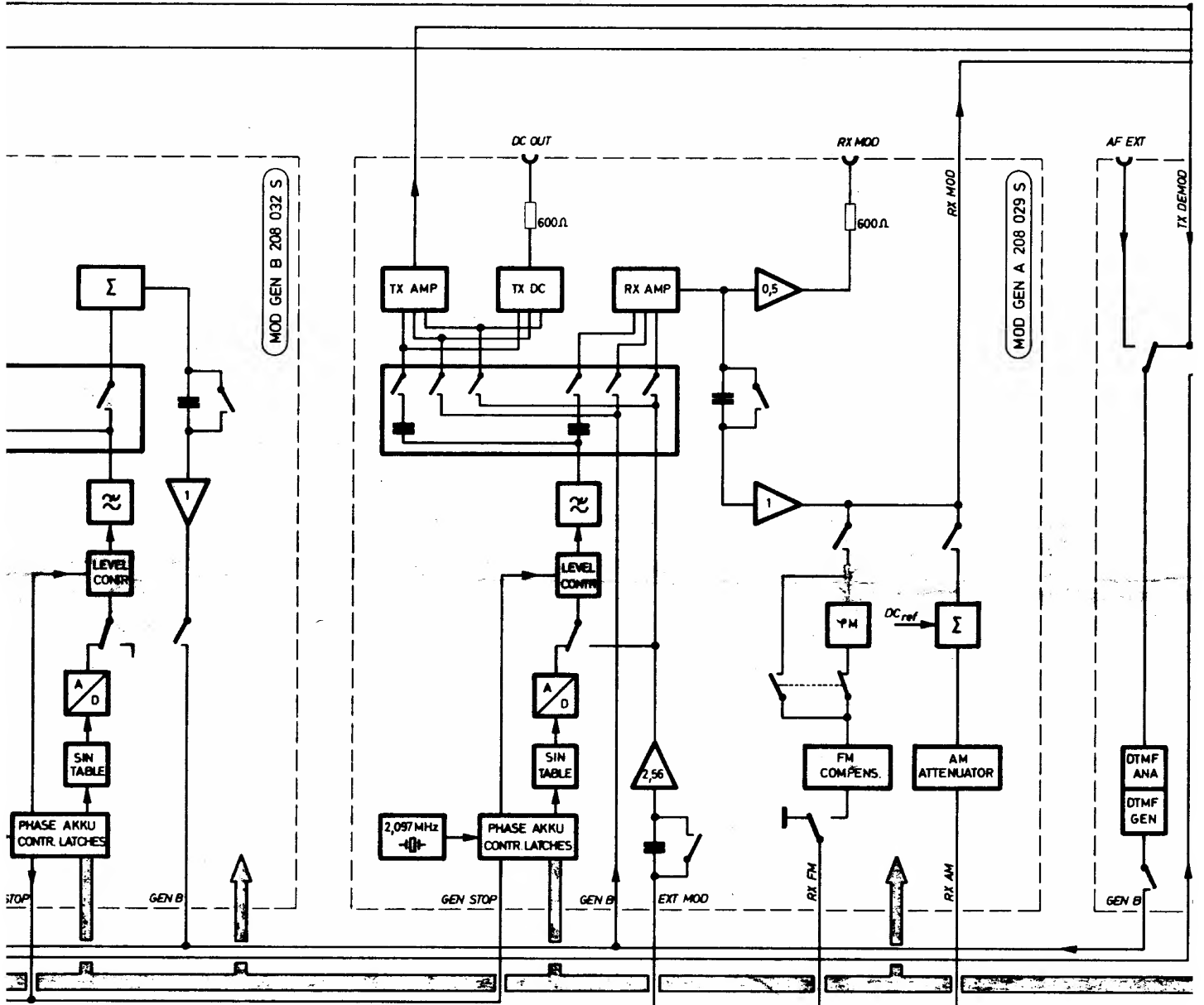

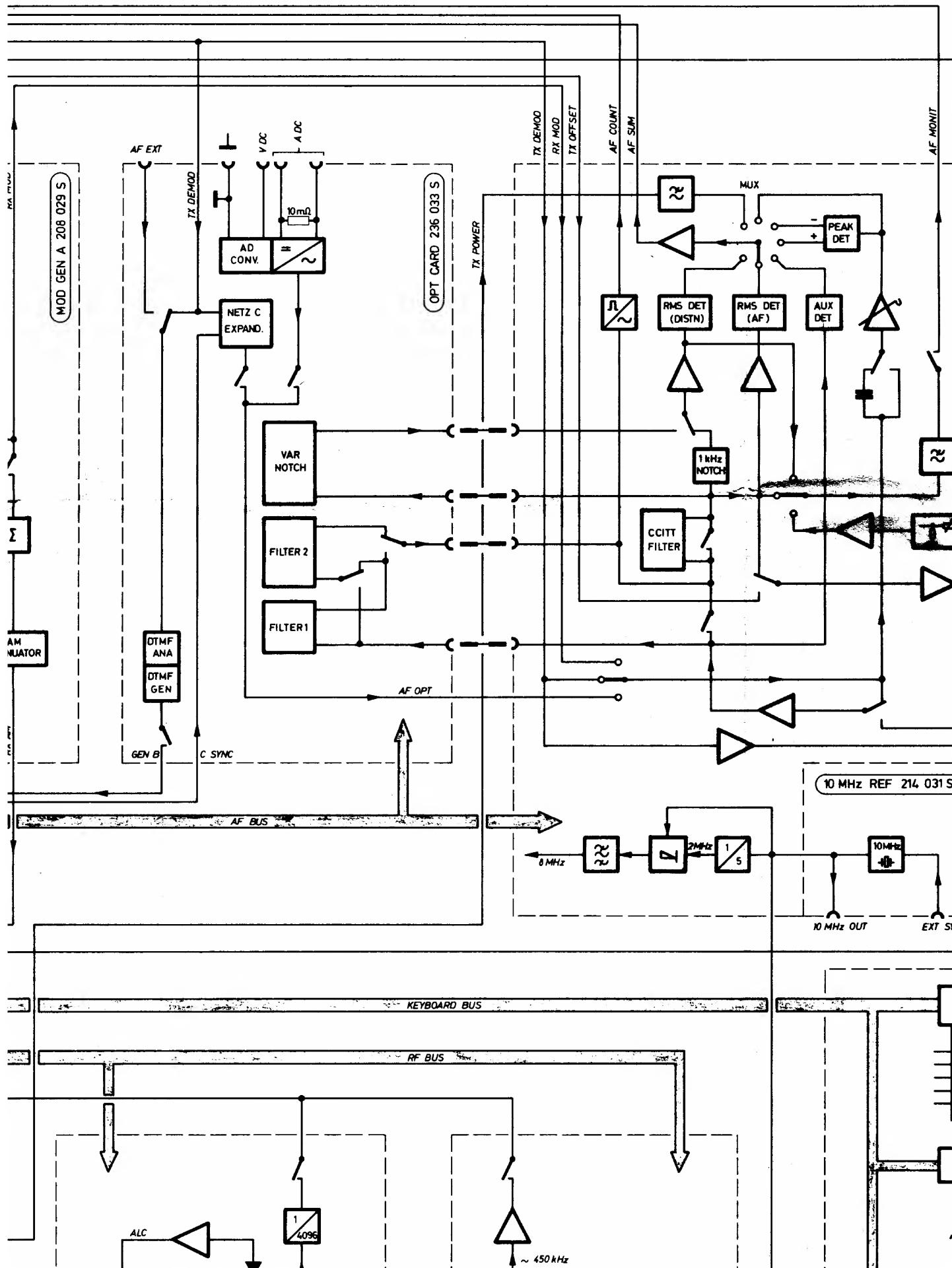

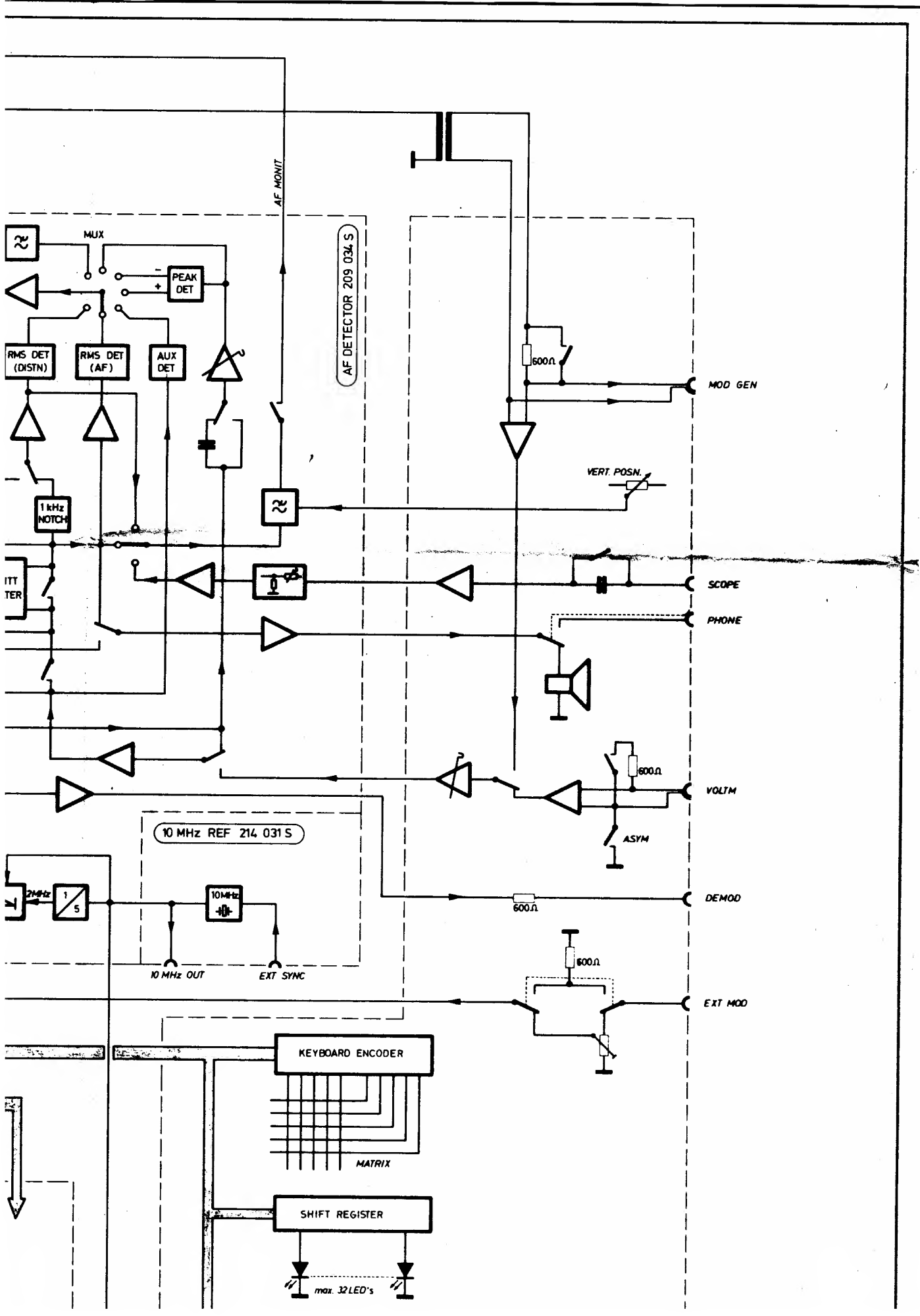

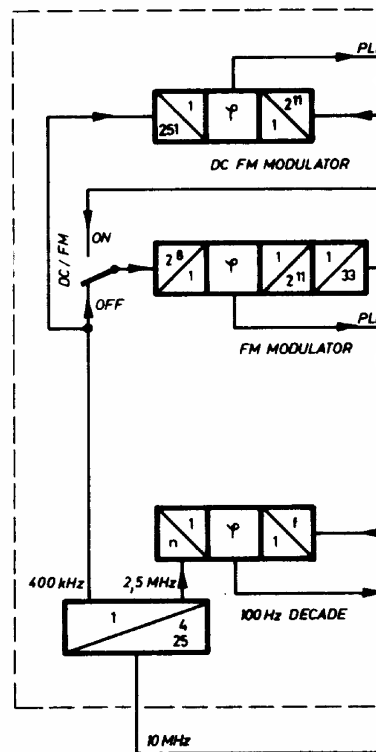
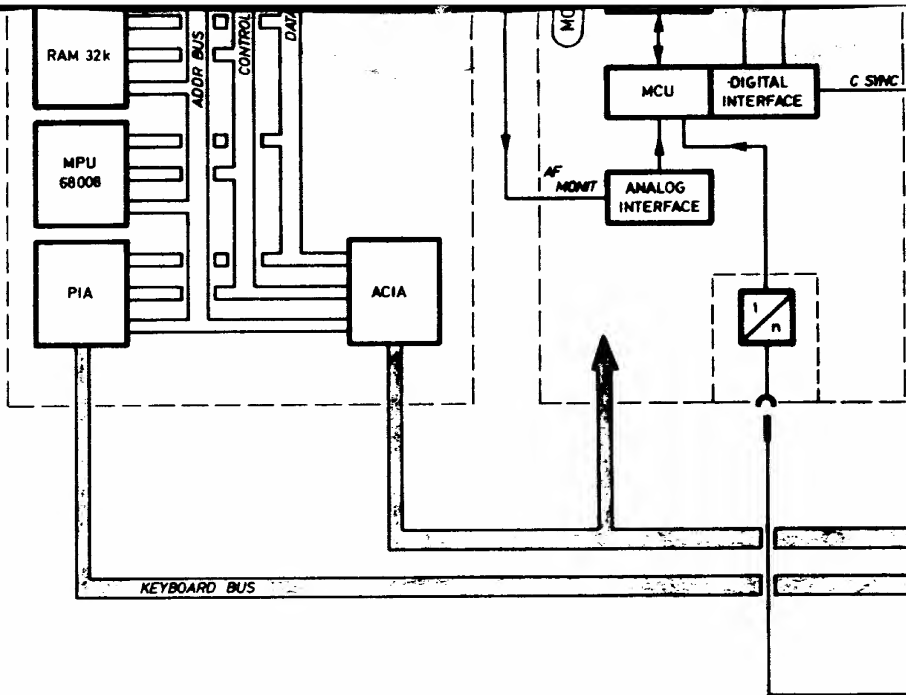

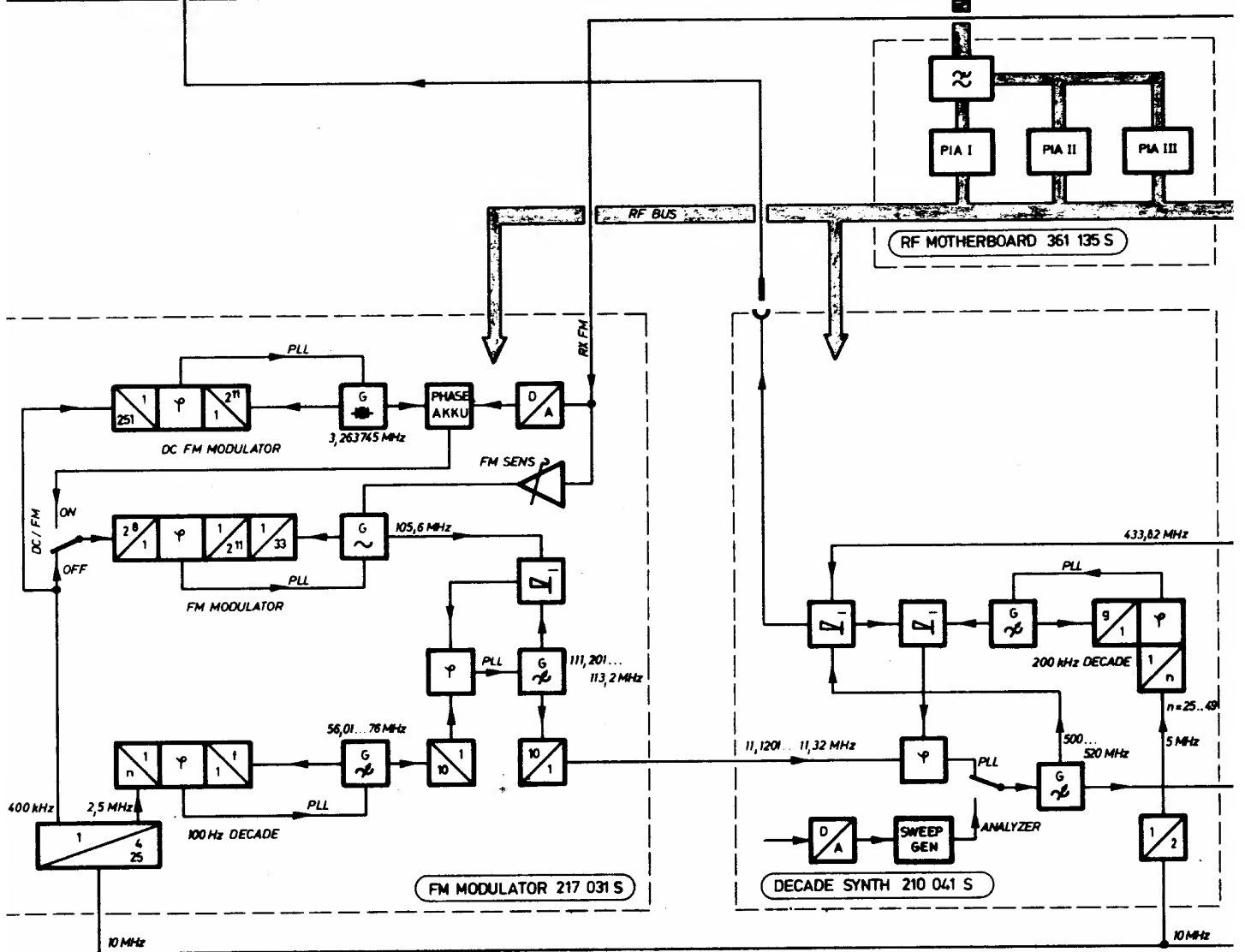
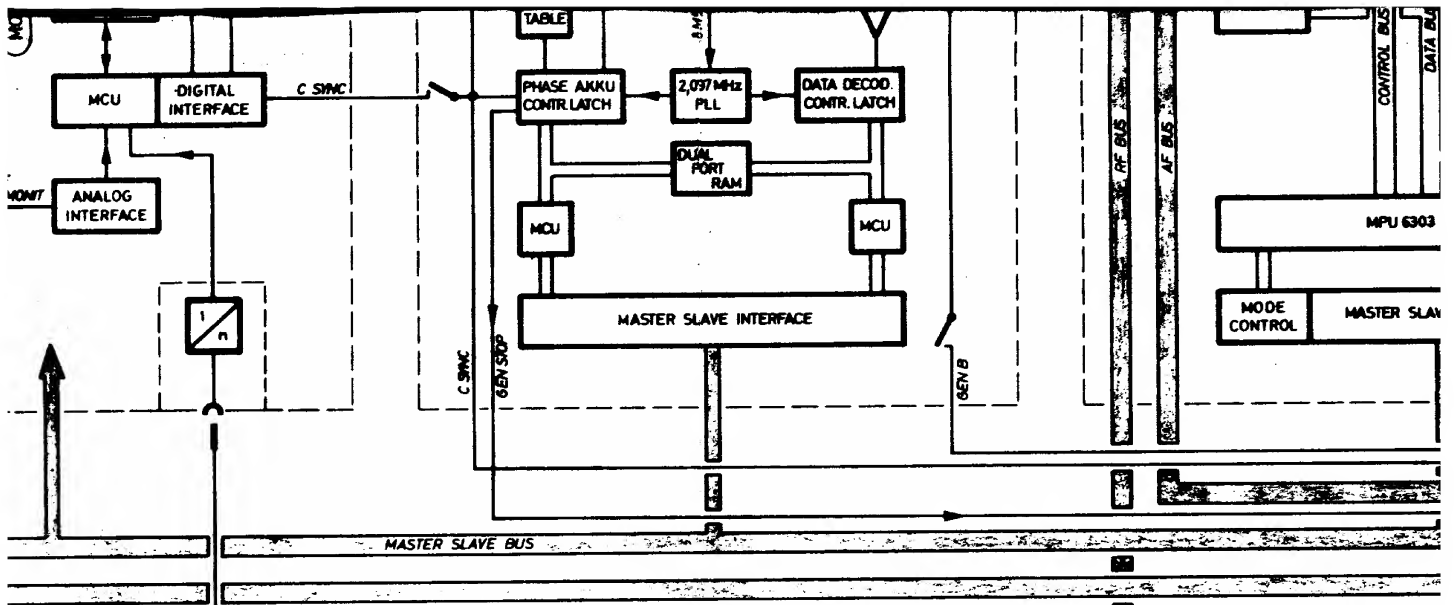



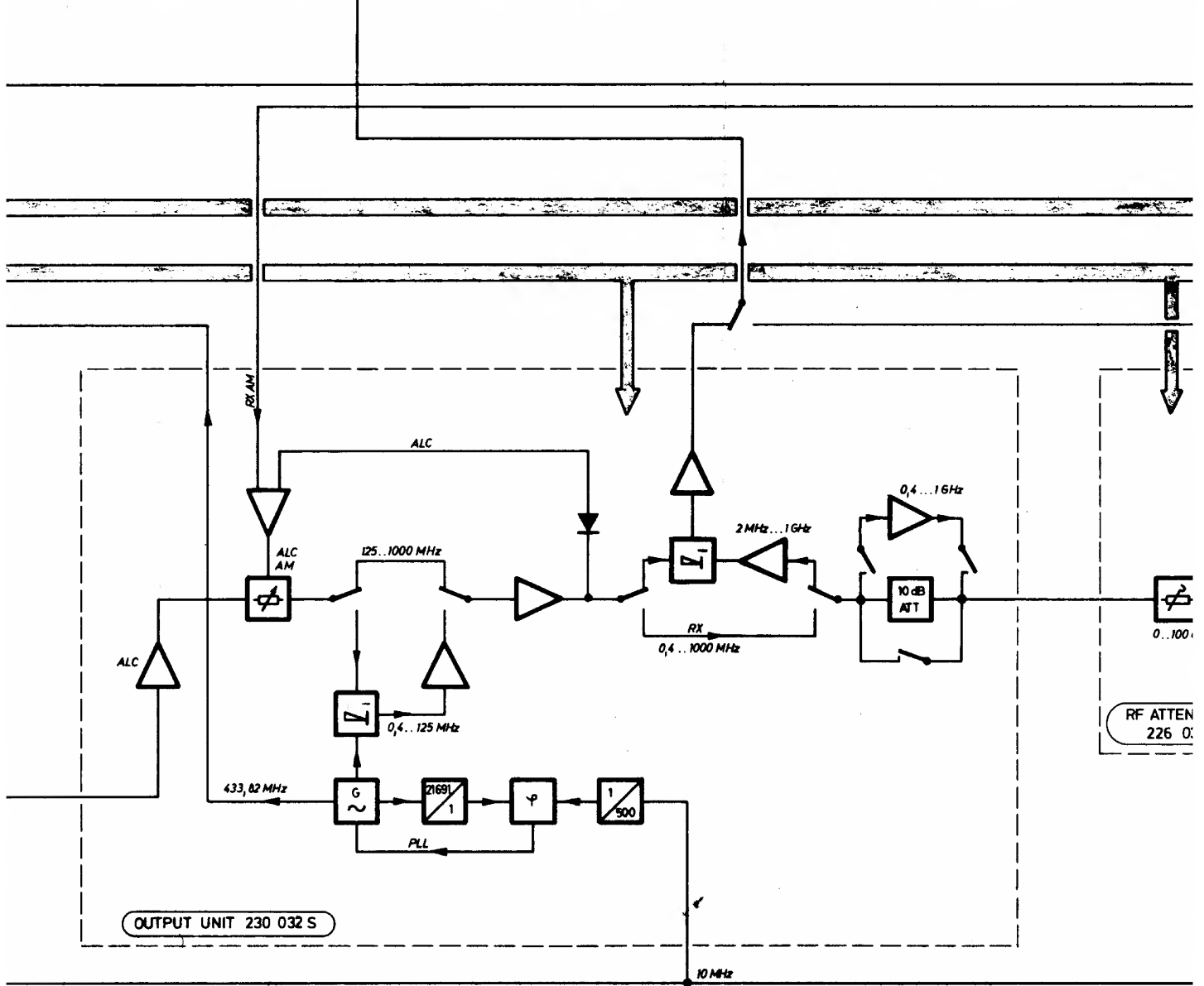
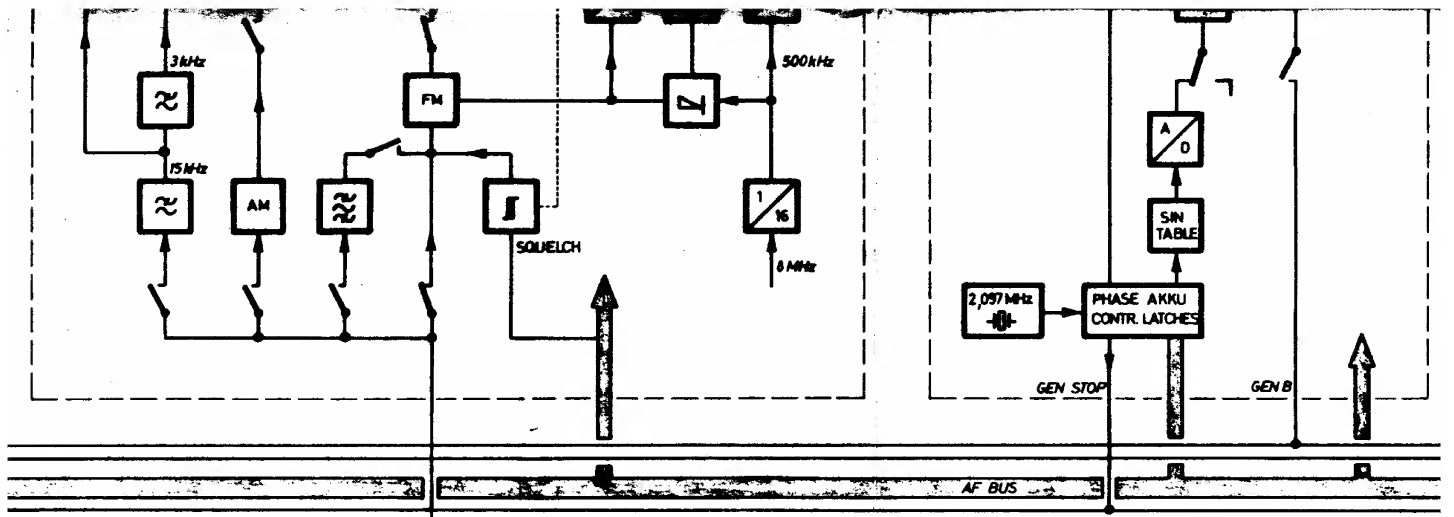

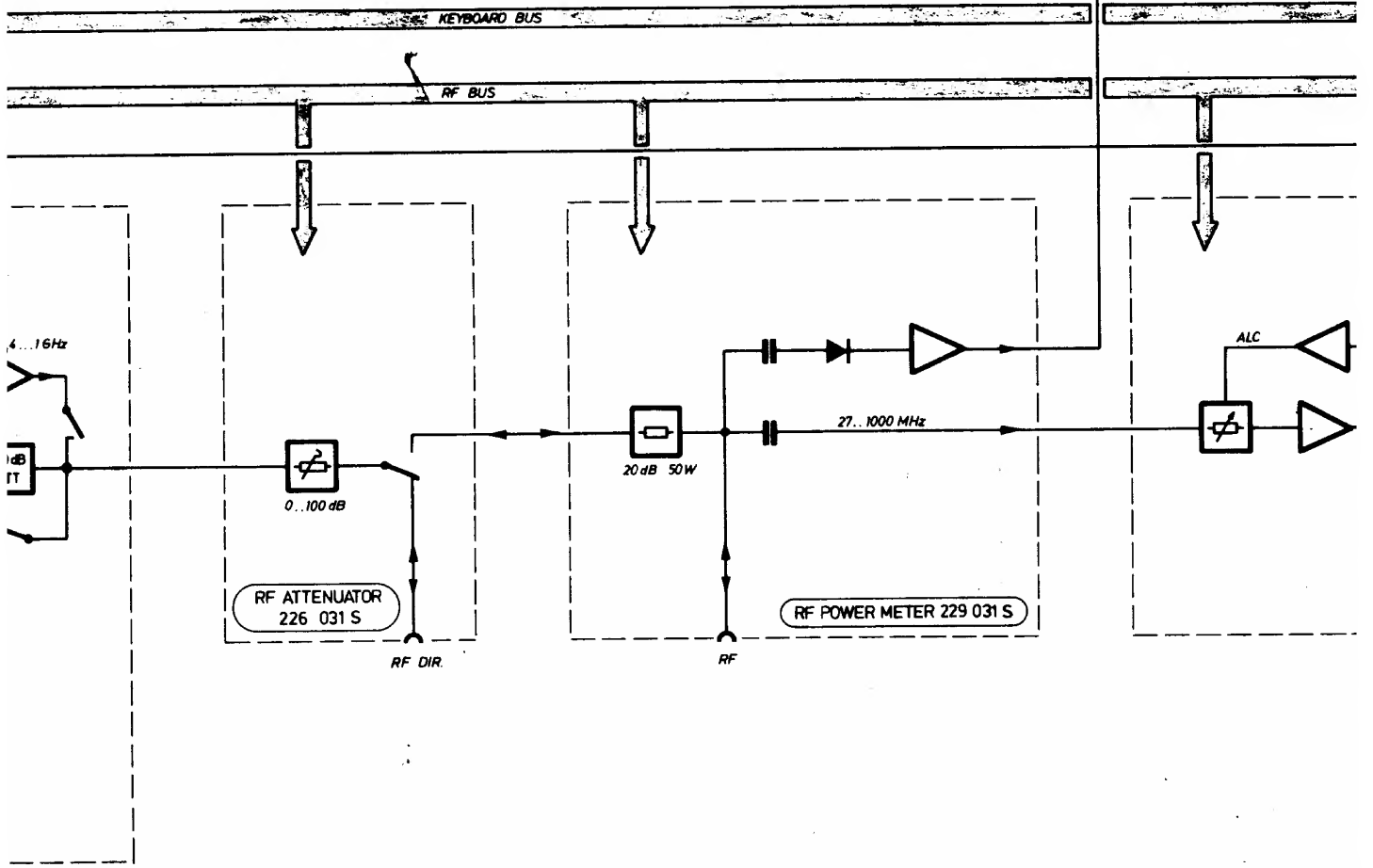
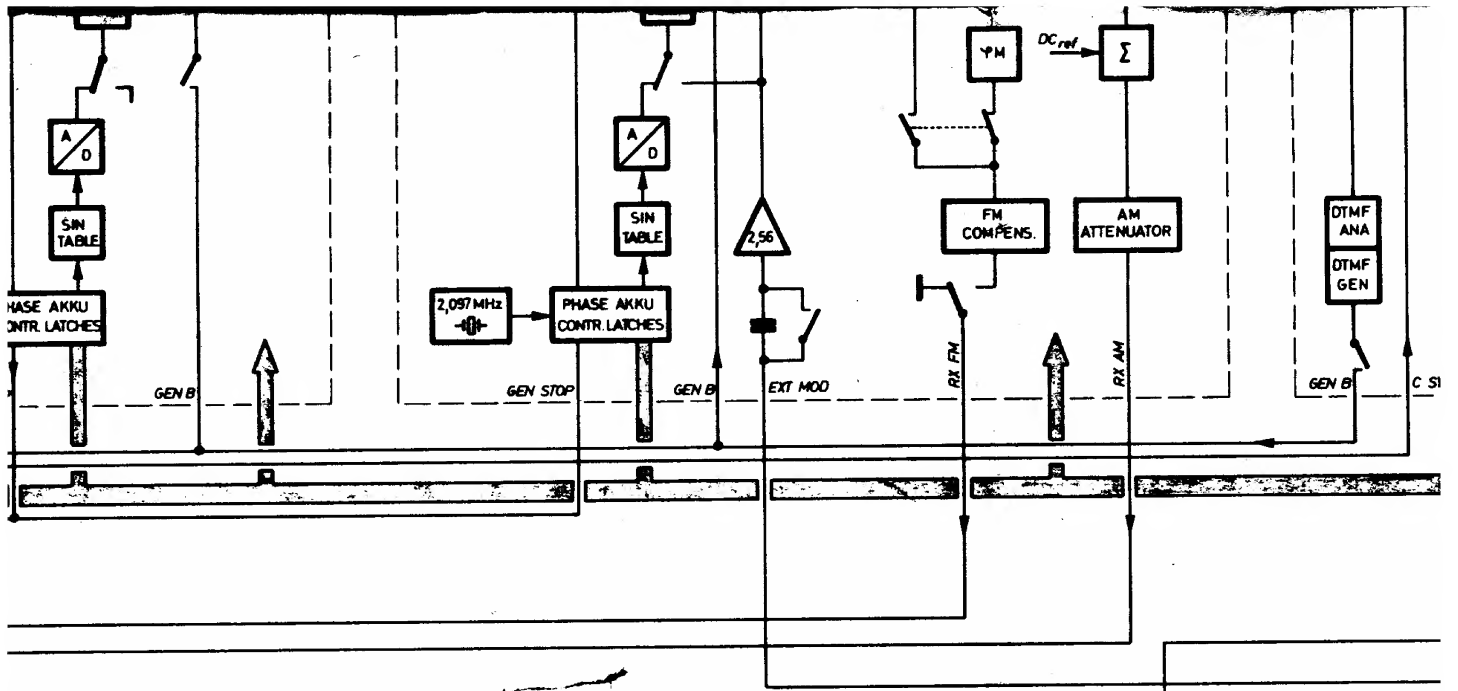



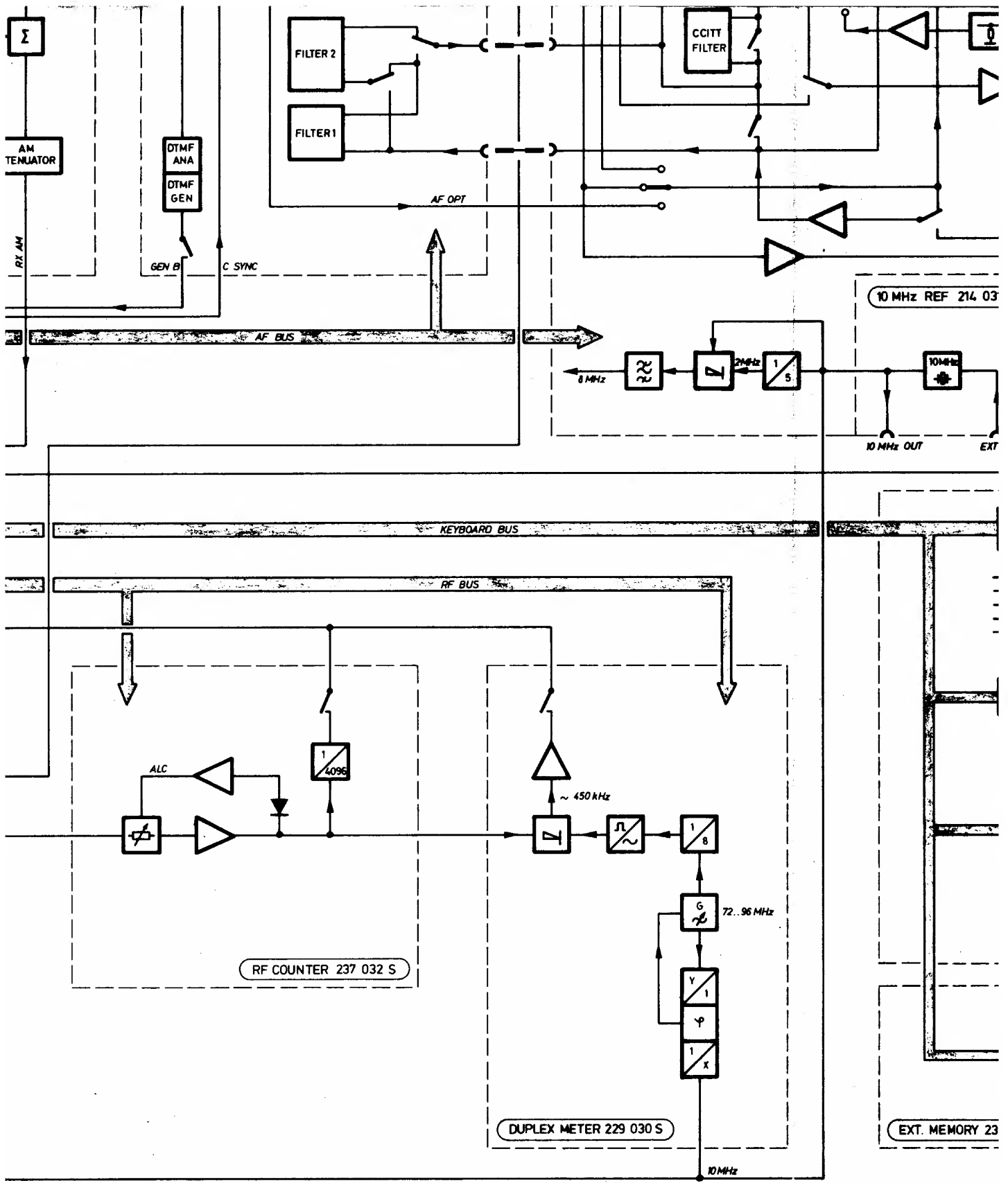

sw BLACK	bl BLUE
br BROWN	vi VIOLET
rt RED	gr GREY
rs ROSE	ws WHITE
ge YELLOW	tr TRANSPARENT
gn GREEN	

03	9808.11	13.2.89	Mg	norm		
Ausg	A-Mittig	Datum	Name	gepr	22.4.88	Kr
ISS	MODIF	DATE	NAME	bepr	1988	
				Datum	Name	
				DATE	NAME	

**Schlumberger o/s**  
 Meßgerätekau + Vertrieb GmbH  
 8 München 46

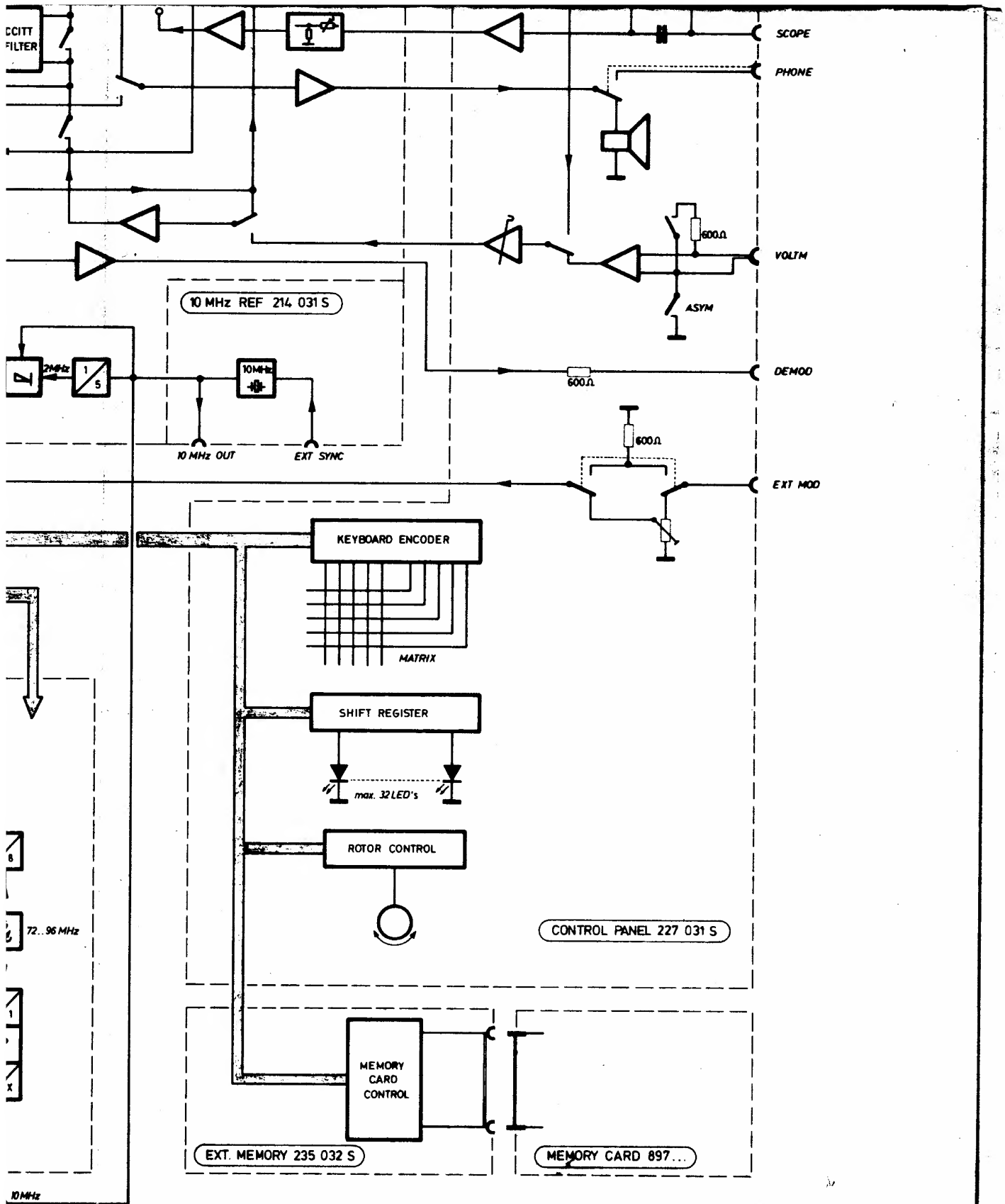

22.4.88 Kr		Schlumberger o/s Meßgerätebau u. Vertrieb GmbH 8 München 46	COMMUNICATION TEST SET	108 800 B
DATE	NAME			

Alle Rechte vorbehalten. Nachdruck, Vervielfältigung und Verbreitung, auch auszugsweise, ist ohne schriftliche Genehmigung der Schlumberger o/s.

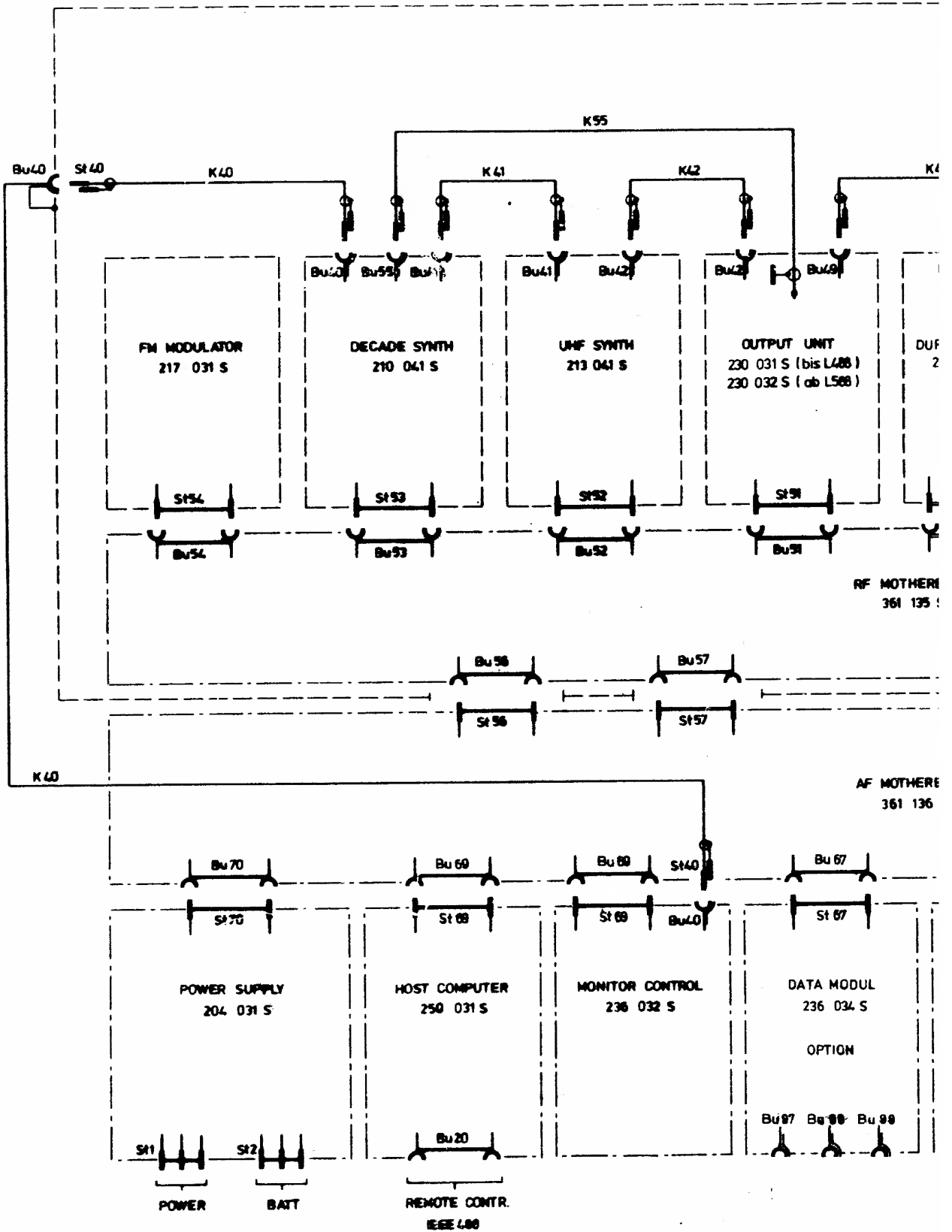

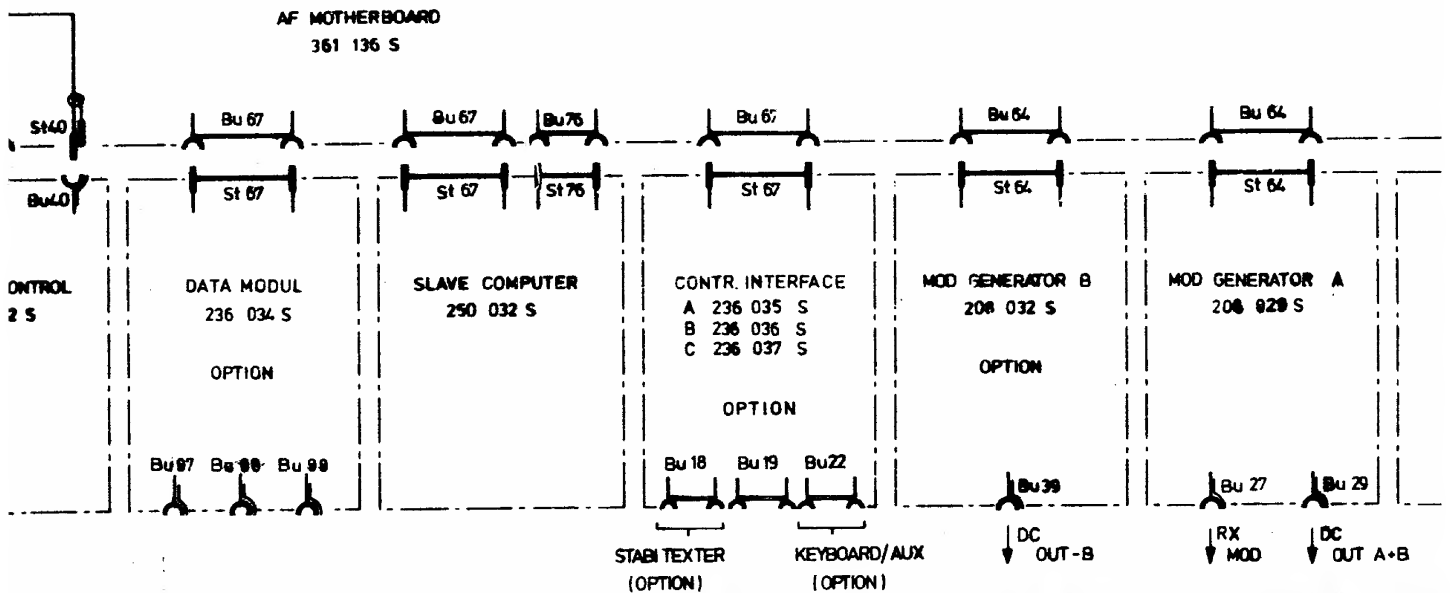
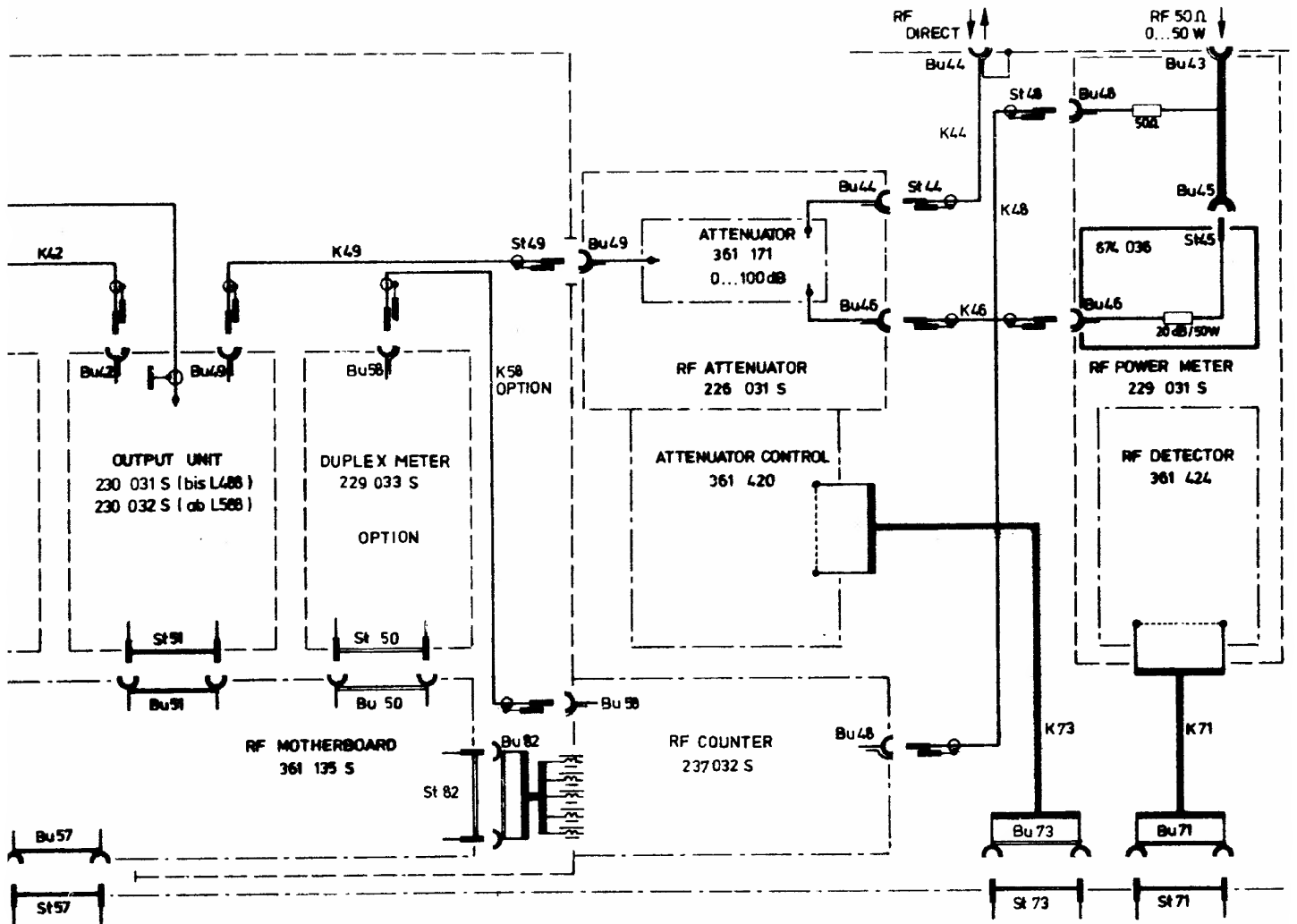

02	8088.19	10.2.88	Kc	name	
01	7088.185	18.11.87	Kc	SNP	25.9.87
03	8088.174	27.9.88	Kc	name	18.2.88
Atrop	A-Messg	Stemp	Name	1987	Datum
REL	KZHF	DATE	NAME		DATE

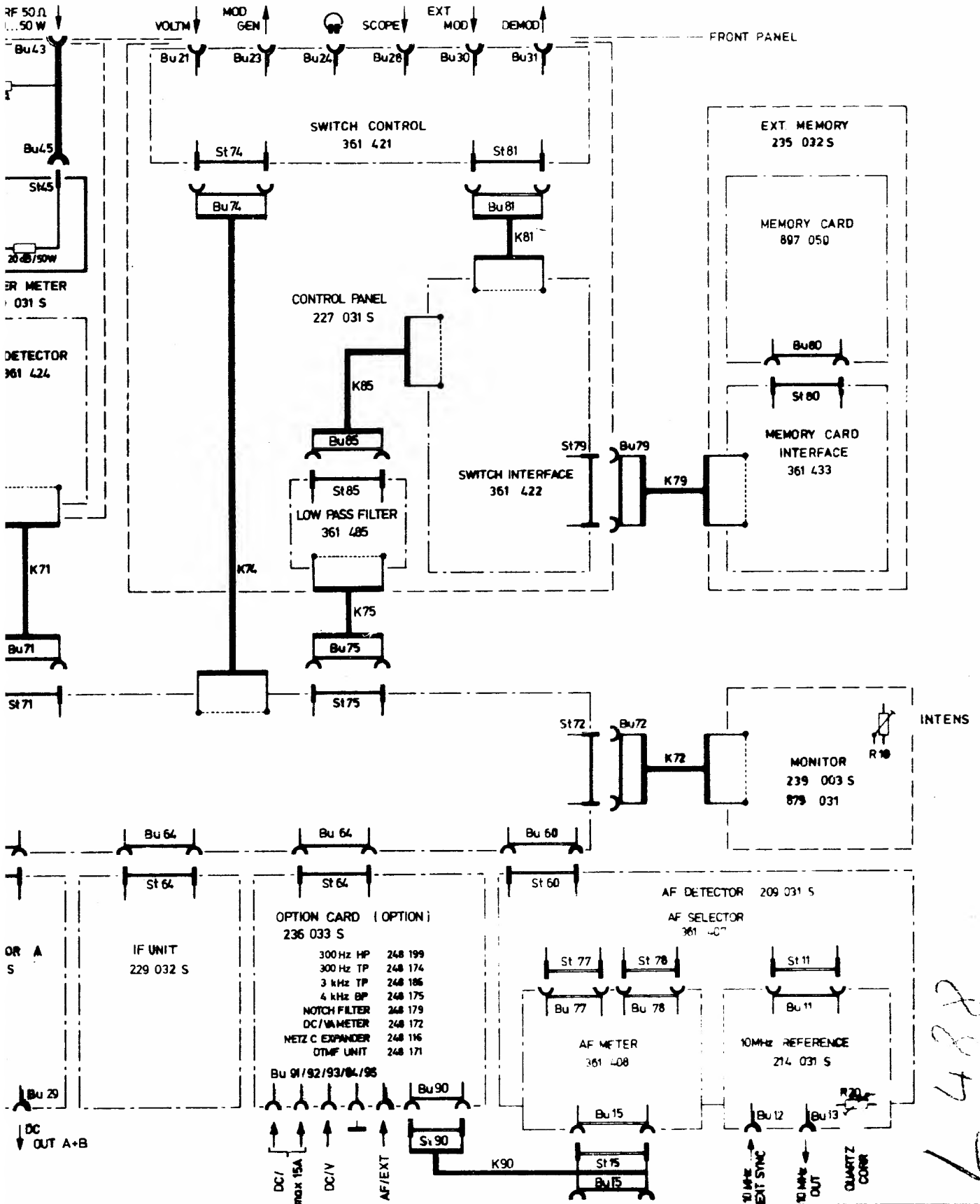

name		Schlumberger Maßgeräte GmbH Ingoletztaler Straße 67 a 8000 München 46	<b>COMMUNICATION TEST SET</b>	<b>201 231 S</b>
SPF	23982			
mark	TR 200/10			
year	1987	Datum NAME		
		BASE NAME		

© Schlumberger Messtechnik GmbH

AF - MOTHERBOARD  
361 136 S

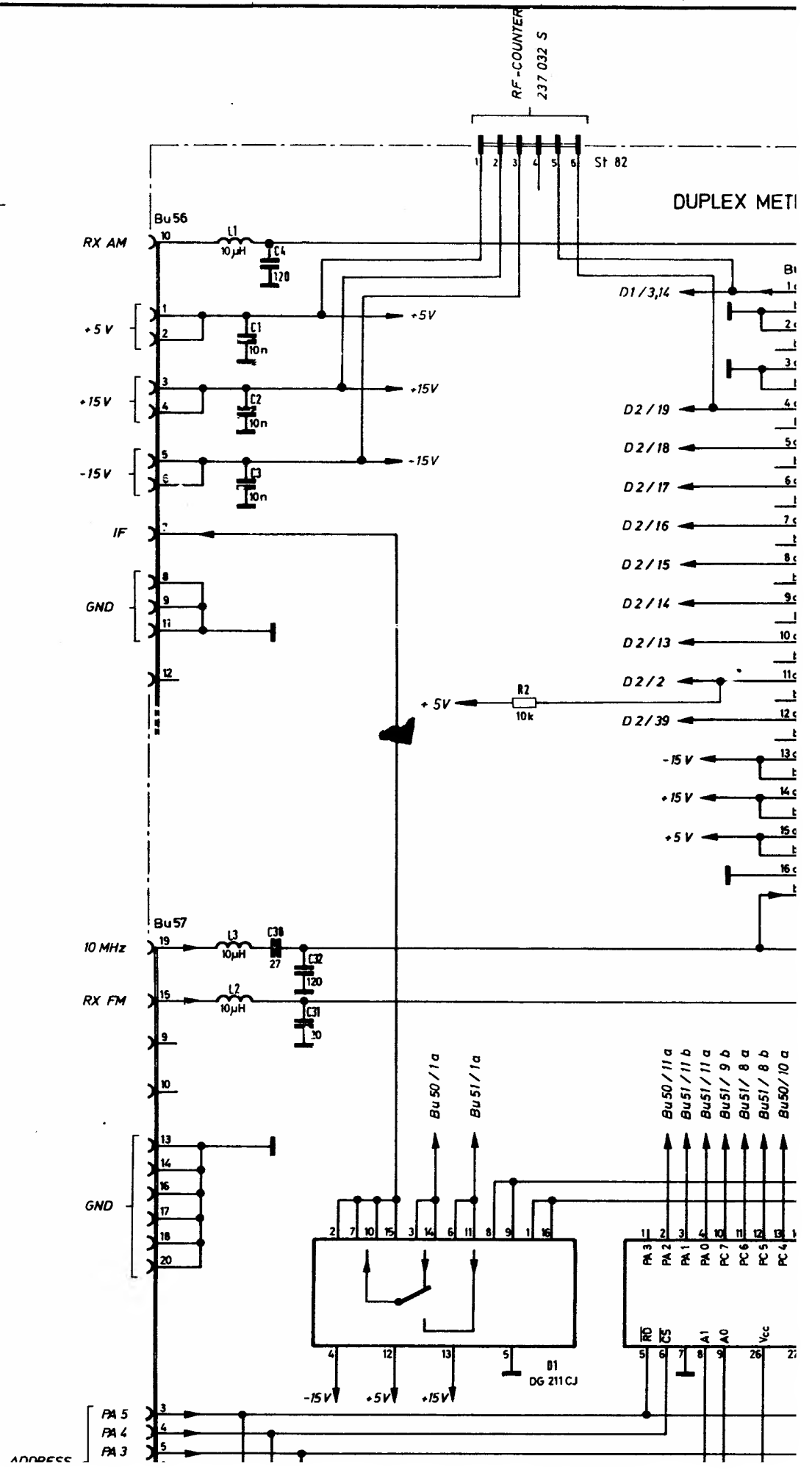

DUPLEX METER 229 030 S

OUTPUT UNIT 230 031 S

UHF SYNTH. 213 041 S

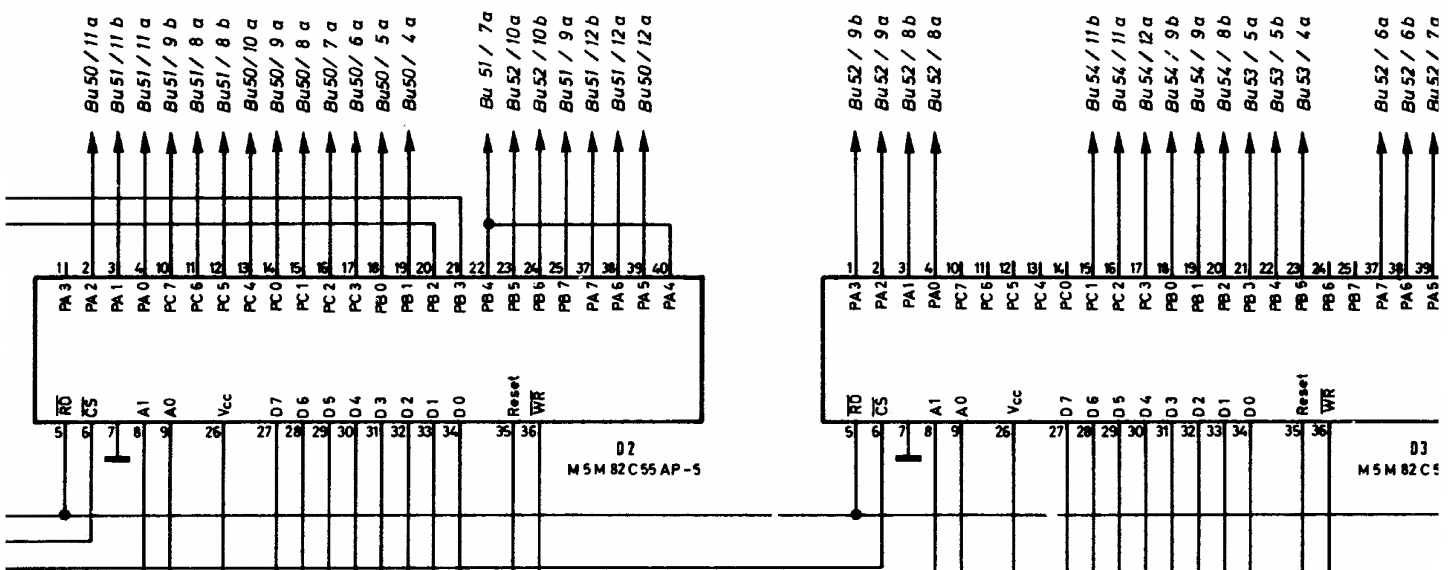
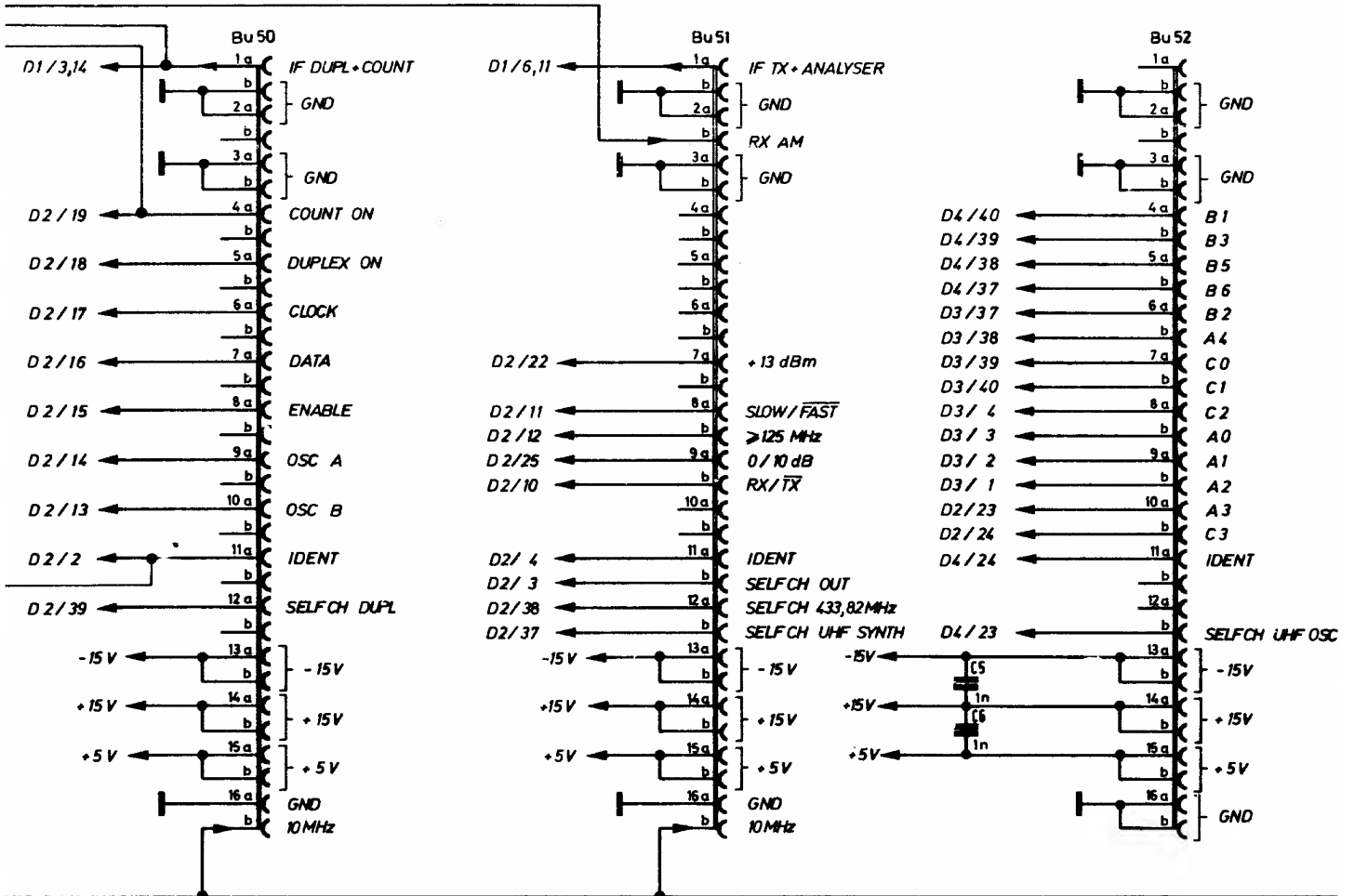

NTH. 213 041 S

DECADE SYNTH. 210 041 S

FM MODULATOR 217 031 S

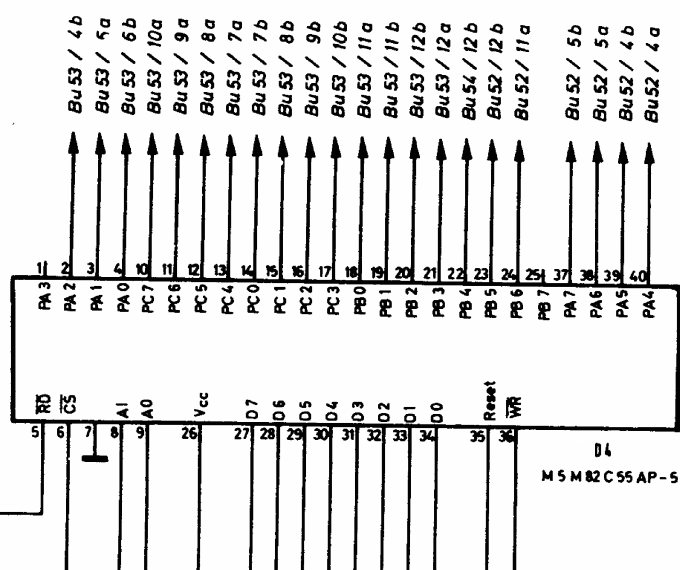
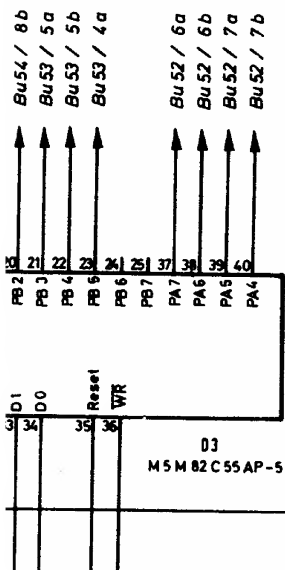
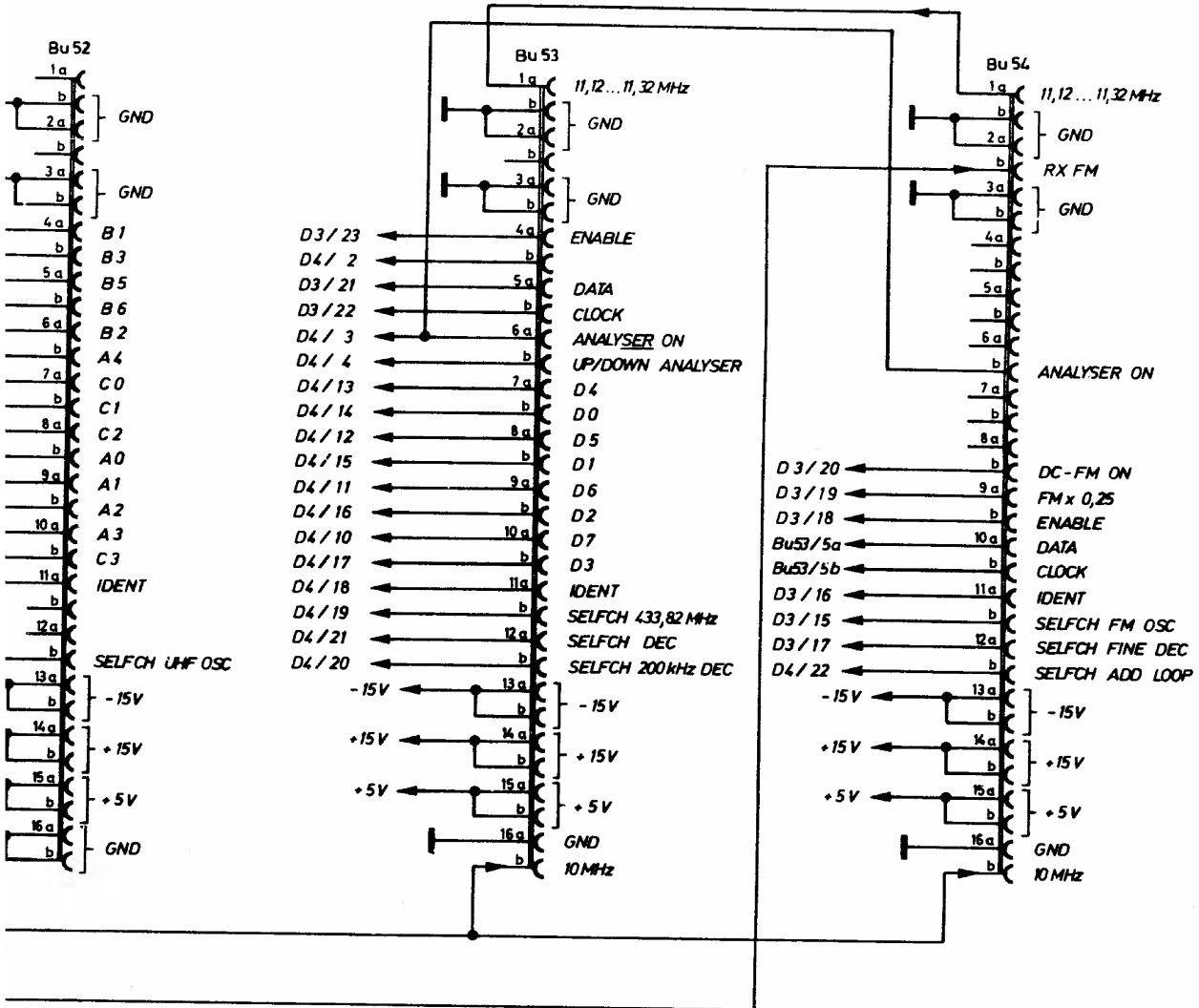







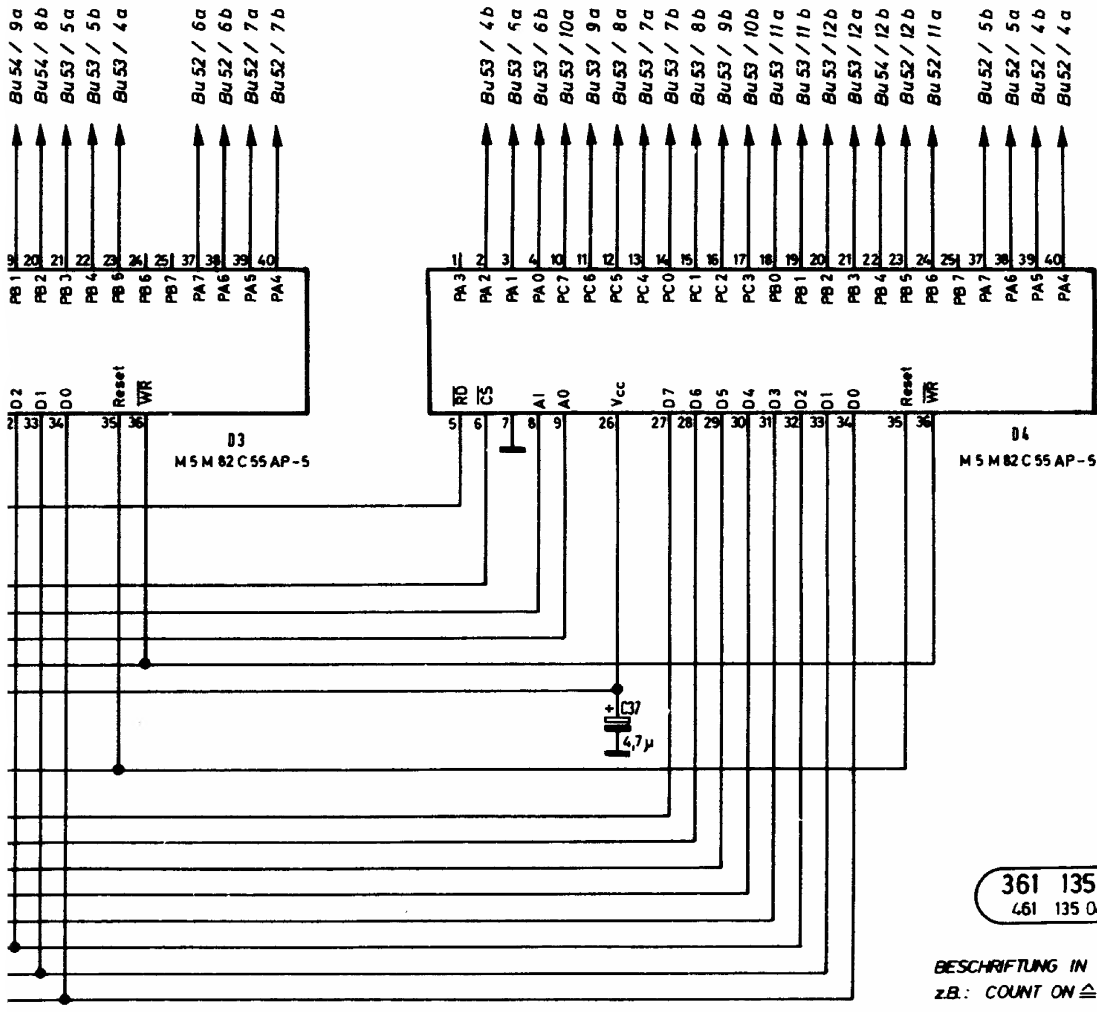
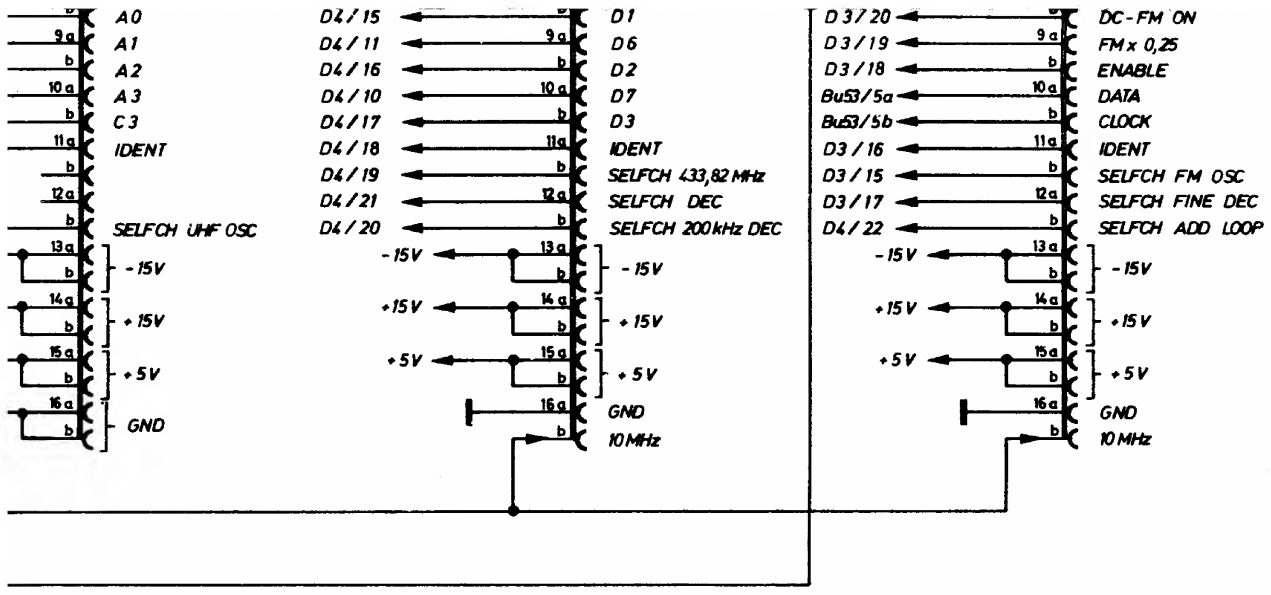

361 135  
461 135 04

BESCHRIFTUNG IN POS. LOGIC  
z.B.: COUNT ON  $\triangleq$  HIGH

norm		Kc	Schlumberger o/s	RF MOTHERBOARD	361 135 S
gepr					
beorb	9.9.86	Kc	Meßgerätebau u. Vertrieb GmbH		
1986	DATE	NAME	8 München 46		Typ: 4031

Zeichnungsausgabe

ISSUE  $\triangle$  Serie

361 136

481 136 03

04 L 488  
05 L 588

- CB 1 1a
- PB 6 1b
- PB 7 1c
- PB 5 1d
- PB 4 1e
- PB 3 1f
- PB 2 1g
- PB 1 1h
- PB 0 1i
- PA 7 2a
- PA 6 2b
- CB 2 2c
- PA 4 2d
- PA 5 2e
- PA 2 2f
- PA 3 2g
- PA 0 2h
- PA 1 2i
- CA 2 3a
- CA 1 3b

Bu76  
SLAVE COMPUTER

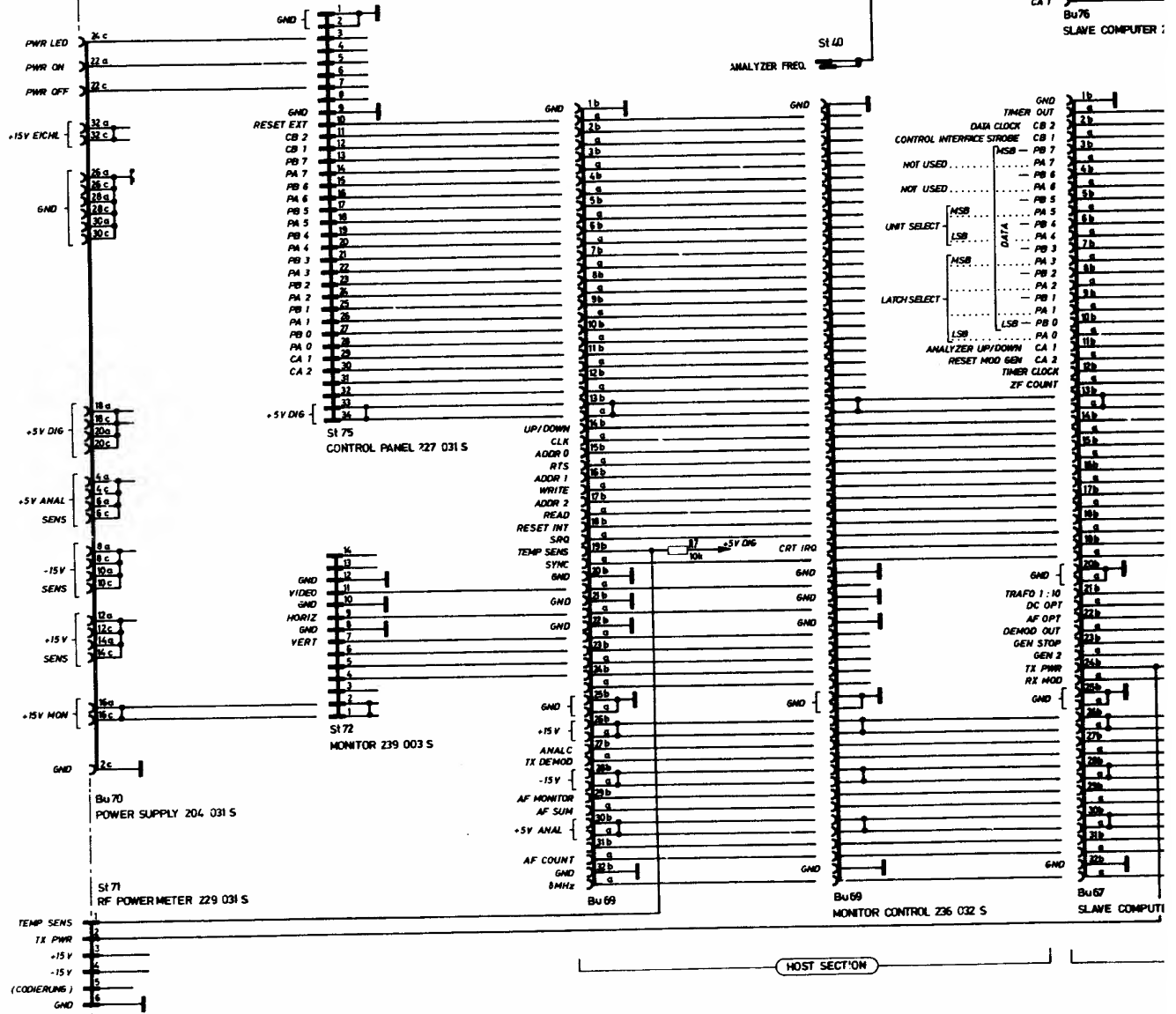

HOST SECTION



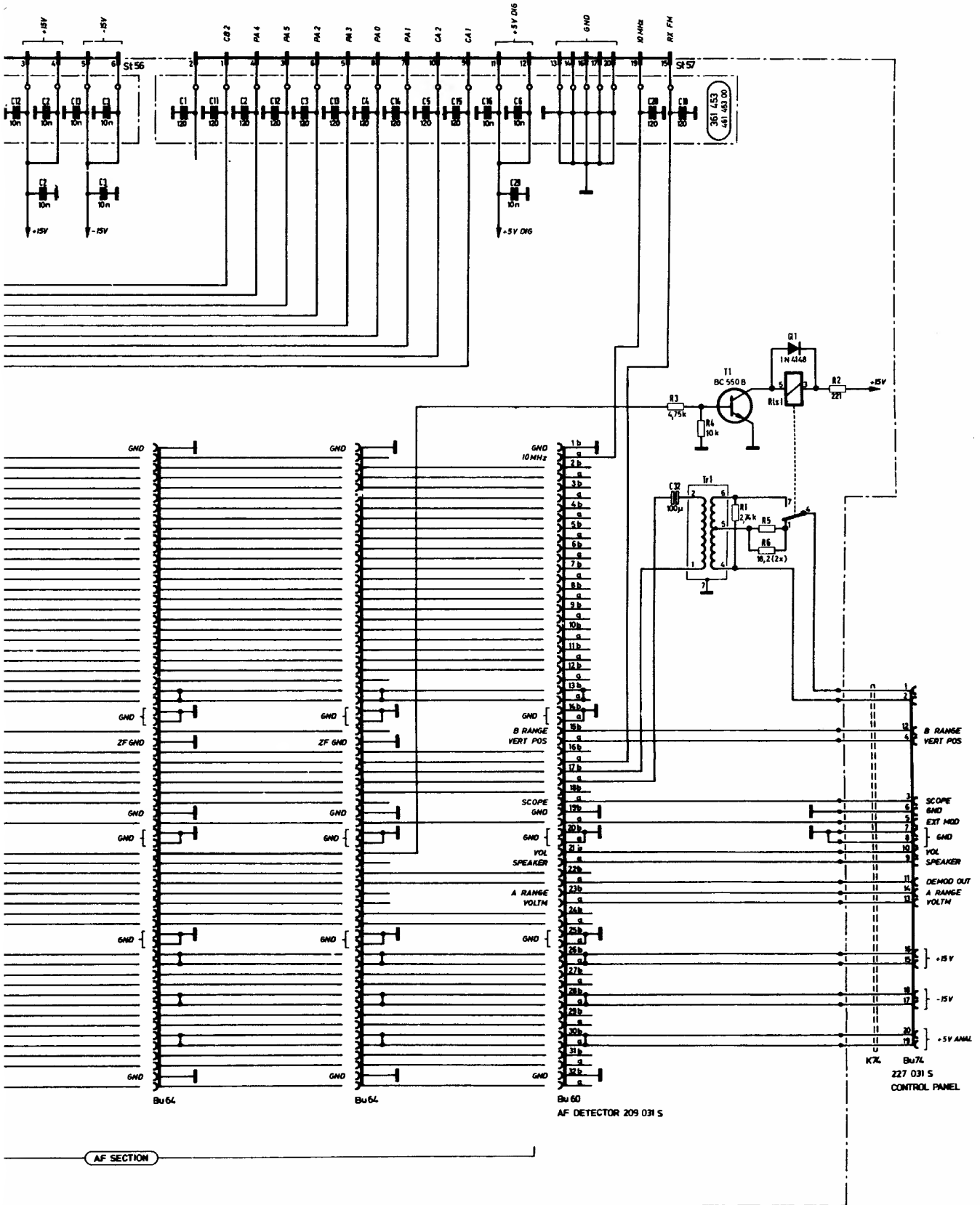

AF SECTION

ICI	W BLAU	OS	21.08.53	19.9.58	Kr	name	
WV	V VIOLET	21	22.8.6	19.4.6	SL	nr	21.2.6
B	GR GREY	22	08.11	21.4.67	SL	nr	20.11.65
BE	WEIß WHITE	23					
LEH	TR. TRANSPARENT	24					
BEH		25					
26		26					
27		27					
28		28					
29		29					
30		30					
31		31					
32		32					
33		33					
34		34					
35		35					
36		36					
37		37					
38		38					
39		39					
40		40					
41		41					
42		42					
43		43					
44		44					
45		45					
46		46					
47		47					
48		48					
49		49					
50		50					
51		51					
52		52					
53		53					
54		54					
55		55					
56		56					
57		57					
58		58					
59		59					
60		60					
61		61					
62		62					
63		63					
64		64					
65		65					
66		66					
67		67					
68		68					
69		69					
70		70					
71		71					
72		72					
73		73					
74		74					
75		75					
76		76					
77		77					
78		78					
79		79					
80		80					
81		81					
82		82					
83		83					
84		84					
85		85					
86		86					
87		87					
88		88					
89		89					
90		90					
91		91					
92		92					
93		93					
94		94					
95		95					
96		96					
97		97					
98		98					
99		99					
100		100					

Schlumberger o/s  
Müllerstraße • Vertriebs GmbH  
8 München 48

AF MOTHERBOARD

361 136 S

Typ: 4031

Diese Zeichnung ist unser Eigentum. Vervielfältigung, unbefugte Vervielfältigung, Mithaltung an andere ist strafbar und schadenersatzpflichtig.

Rückansicht

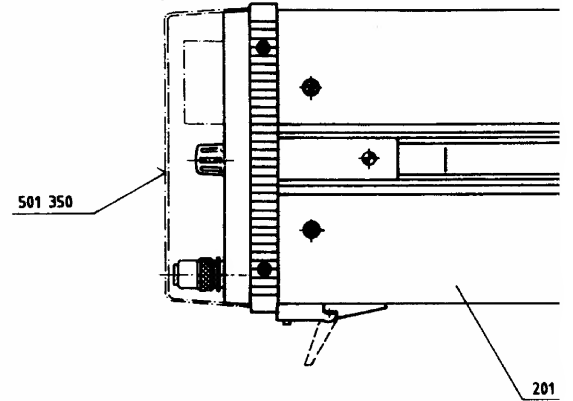
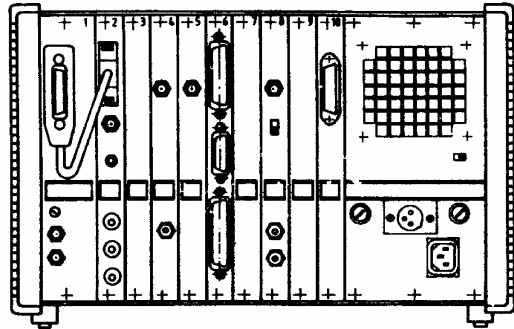

**Option u. Zubehör**

Montage siehe

Tragebügel Kit	378 256
19" Kit	378 257
Tragetasche Kit	378 258
OPTION CARD	236 033

Frontansicht

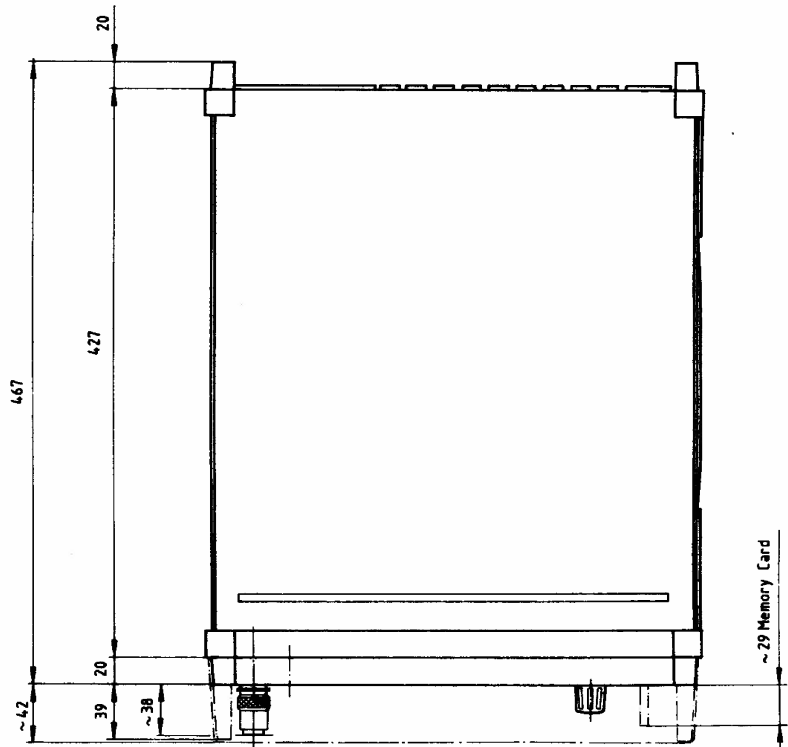
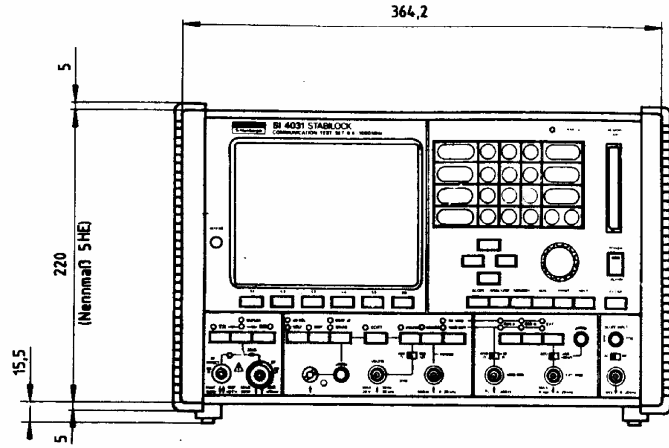
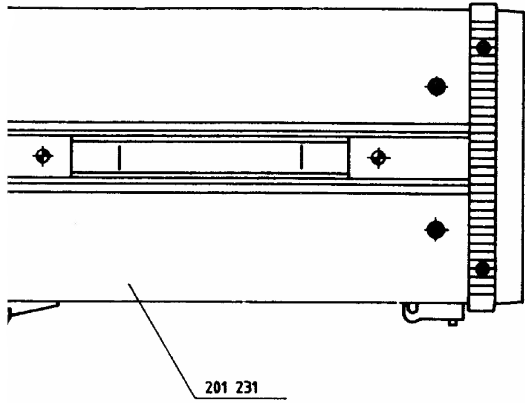

u. Zubehör

siehe

el Kit	378 256
	378 257
che Kit	378 258
ARD	236 033

○ Kontrollmaß

10					Schlumberger Mef Ingostrasser Str. 8000 Munich
09					
08					1:2,5 COMMUN TEST Typ: 4031
07					
06					108 80
05					
04					
03					
02					
01	RS 4031 STABLOCK	Mef	1980	22.6.80	

Gerät:



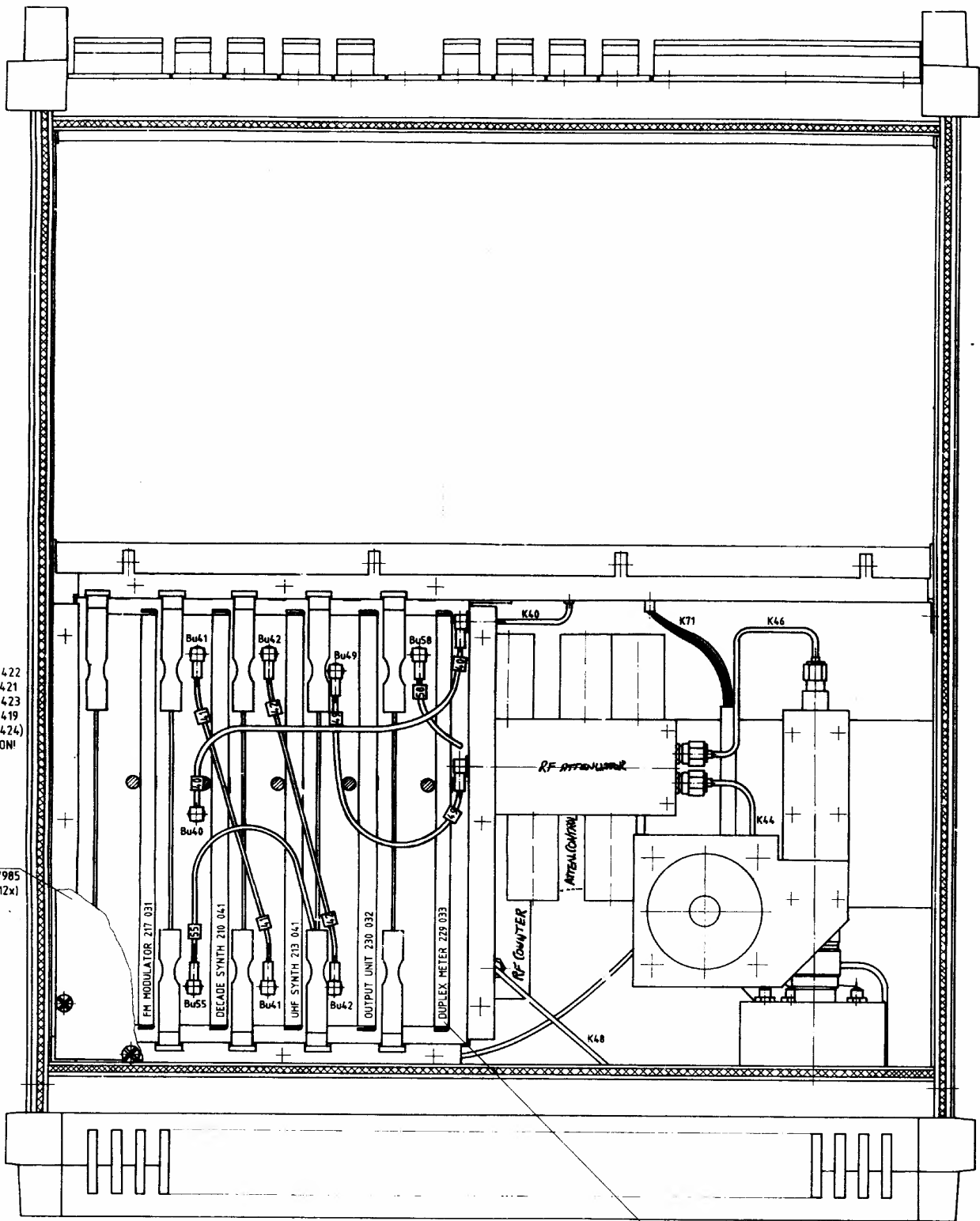

- 40 =382 422
  - 41 =382 421
  - 42 =382 423
  - 49 =382 419
  - 58 =382 424
- OPTION!

431 612  
M3x6 DIN7985  
701 640 (12x)

300 666 (4x)  
Darstellung entspricht jedoch  
den eingebauten Optionen

OPTION!

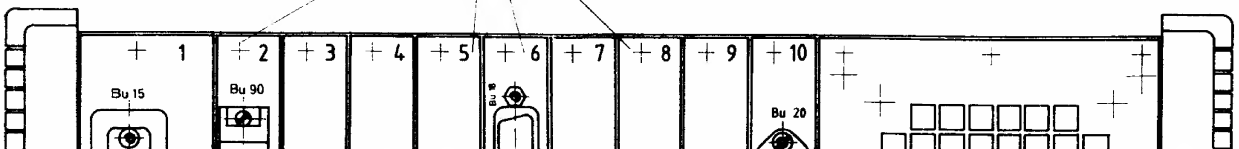

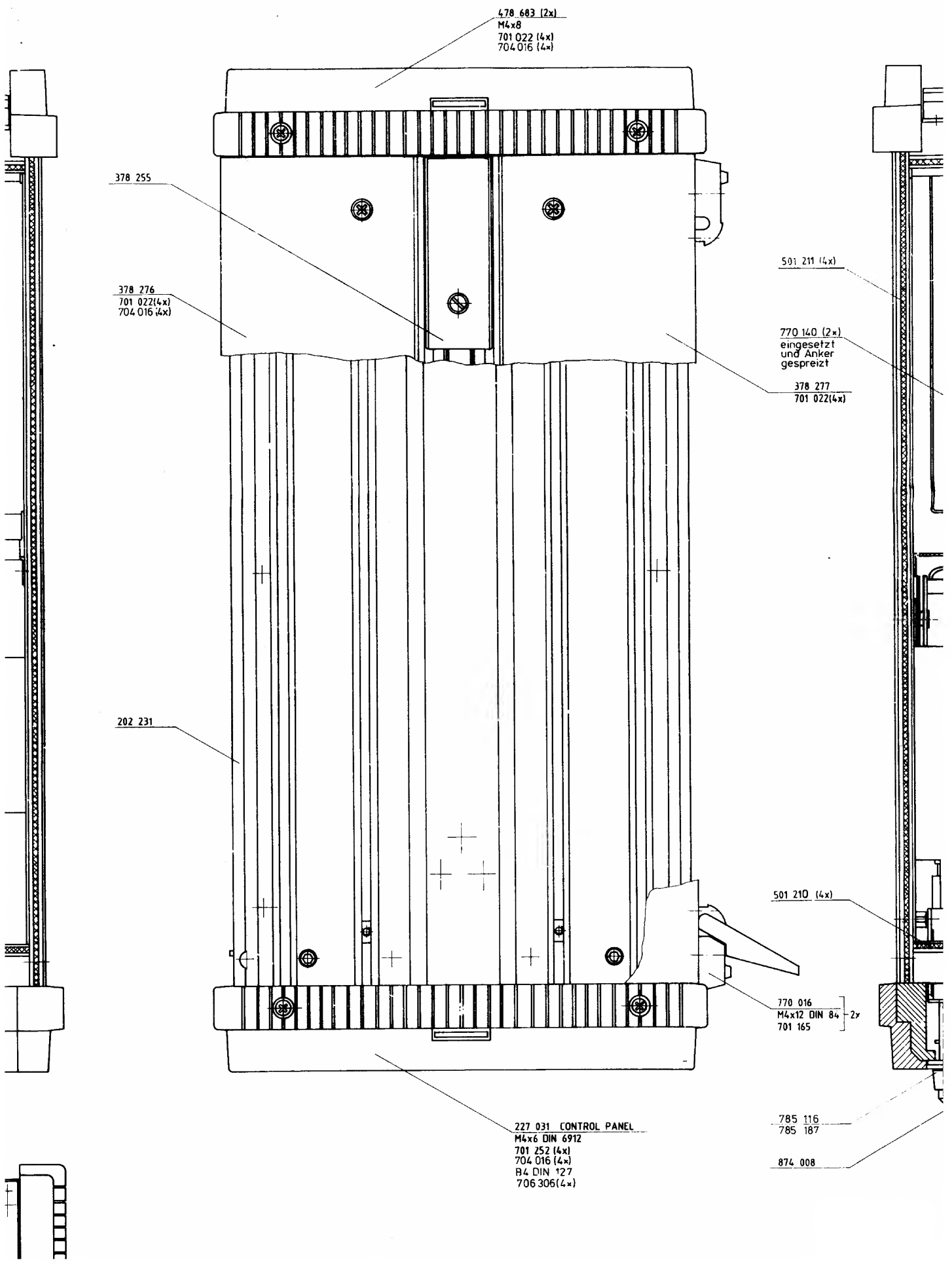

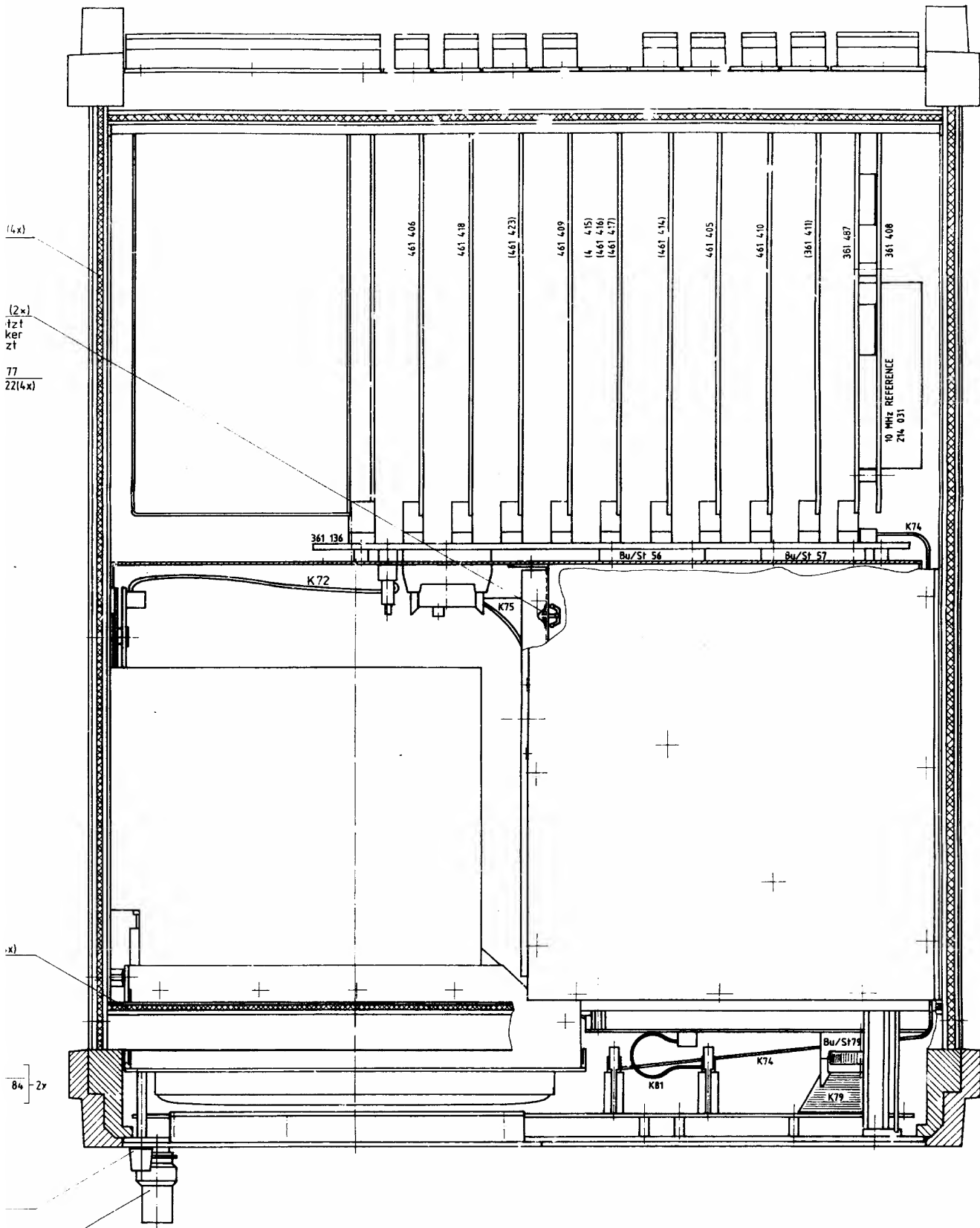

(4x)

(2x)  
tzt  
ker  
zt  
77  
22(4x)

.x)

84-2r

461 406

461 418

(461 423)

461 409

(4 415)

(461 416)

(461 417)

(461 414)

461 405

461 410

(361 411)

361 407

361 408

10 MHz REFERENCE  
214 031

361 136

K74

Bu/St 56

Bu/St 57

K72

K75

K81

K74

Bu/St 79

K79



54 031  
54 032  
54 033  
54 034  
54 035

Schnitt C-D

501 354  
M2,5x25 DIN 84 } 2x  
701 342

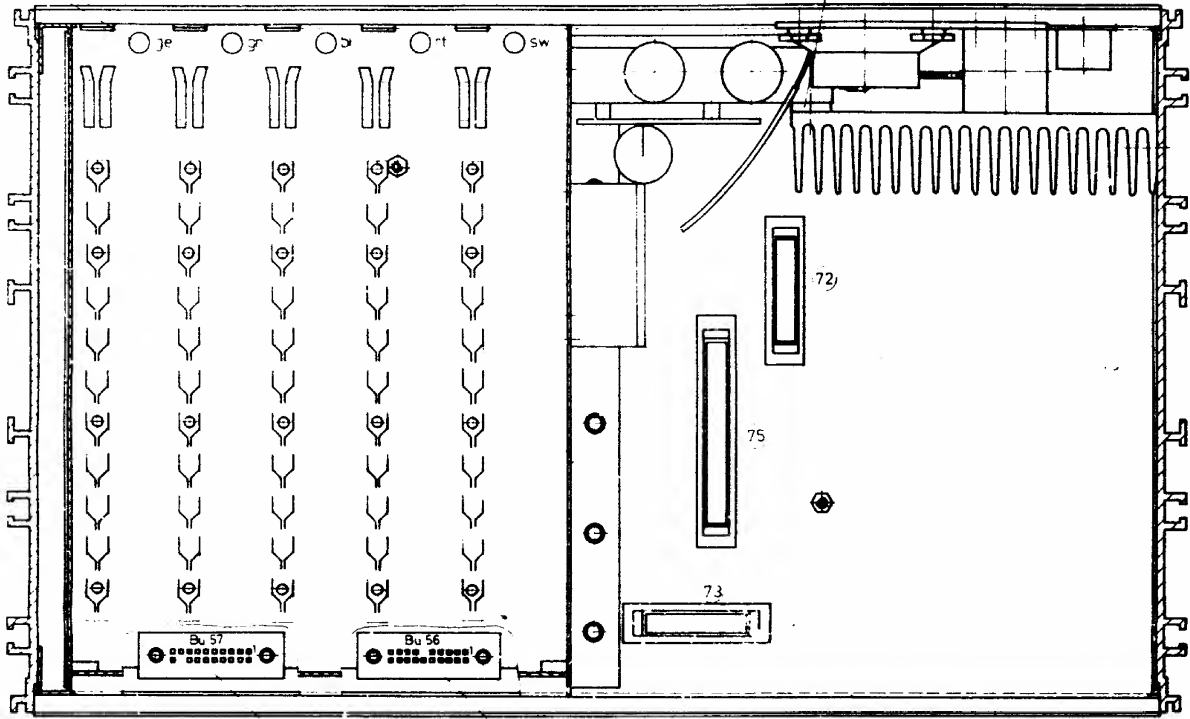

361 453

361 452

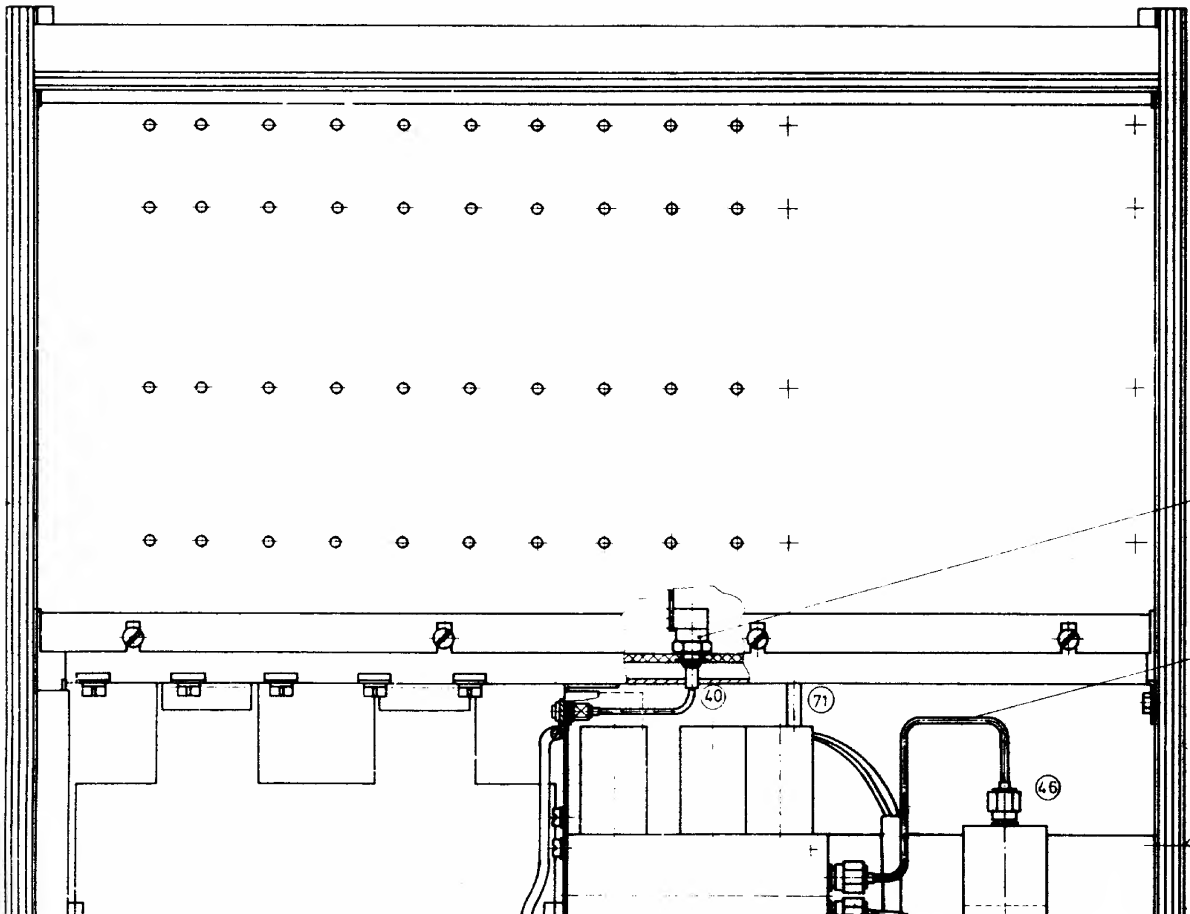

382 414  
706 407  
404 054

382 416  
382 436

M3x6 DI  
701 640  
J 3,2 DIN  
706 105

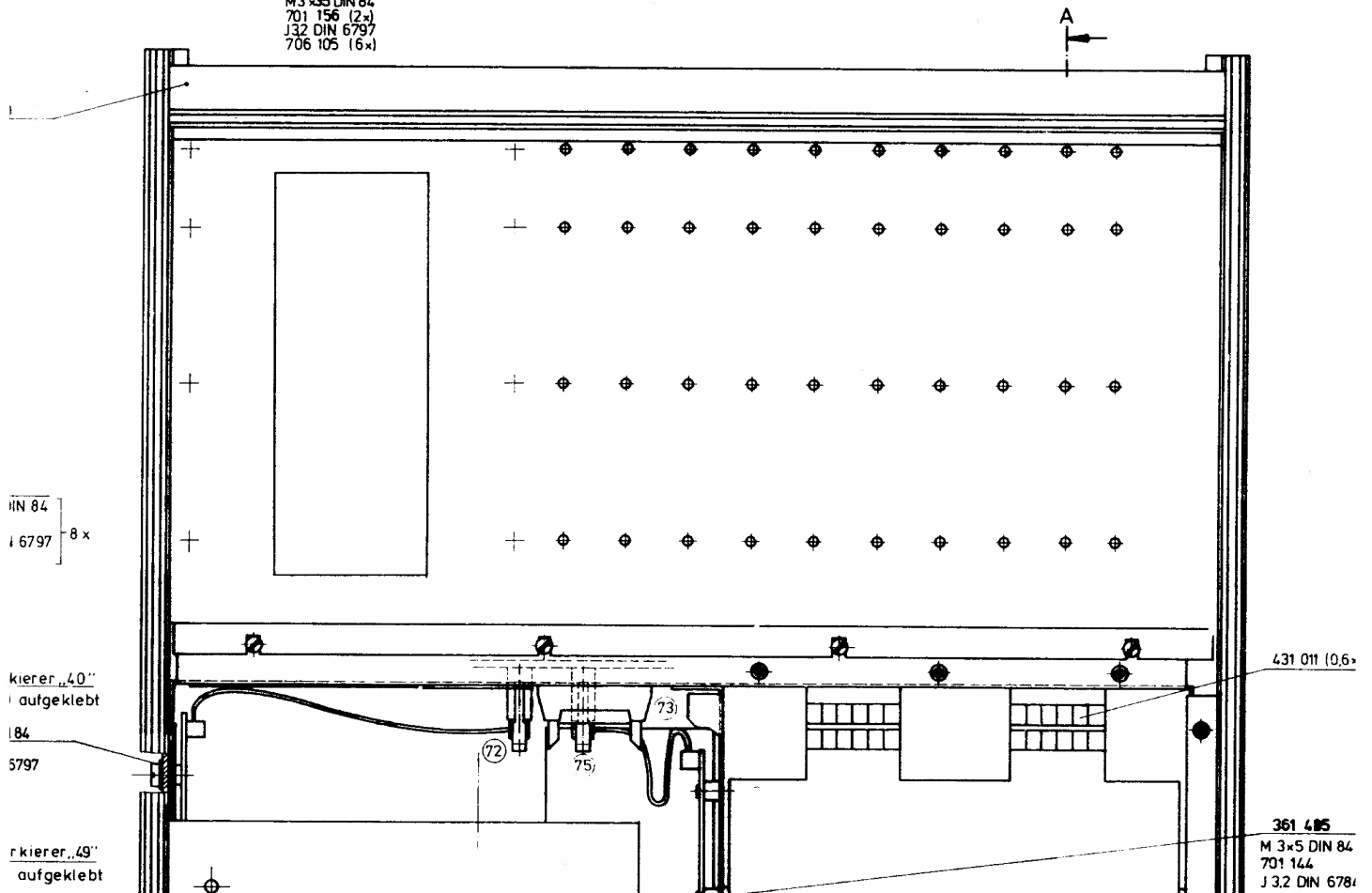
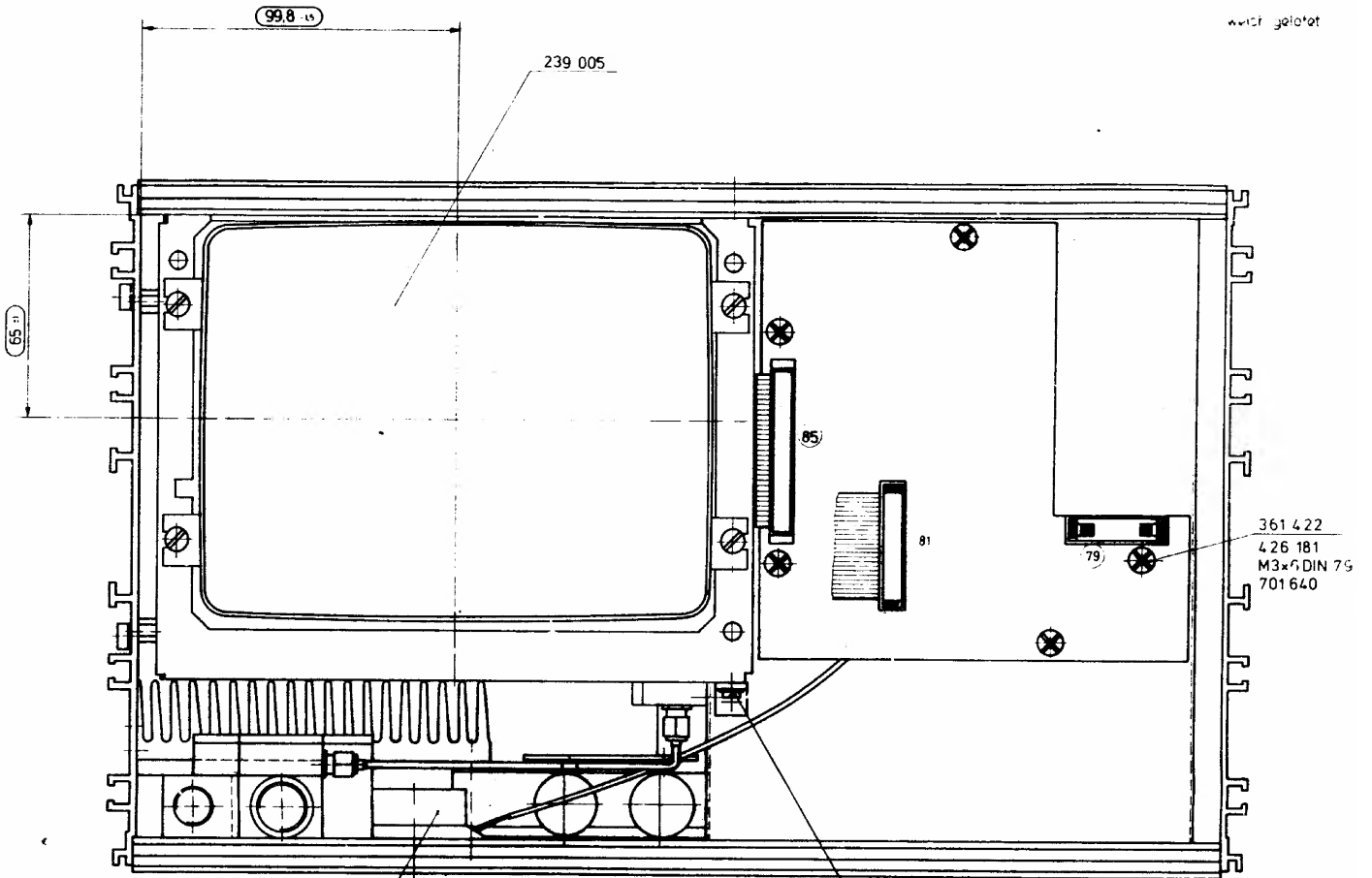

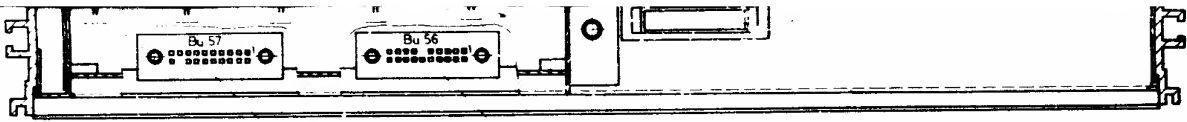

361 453

361 452

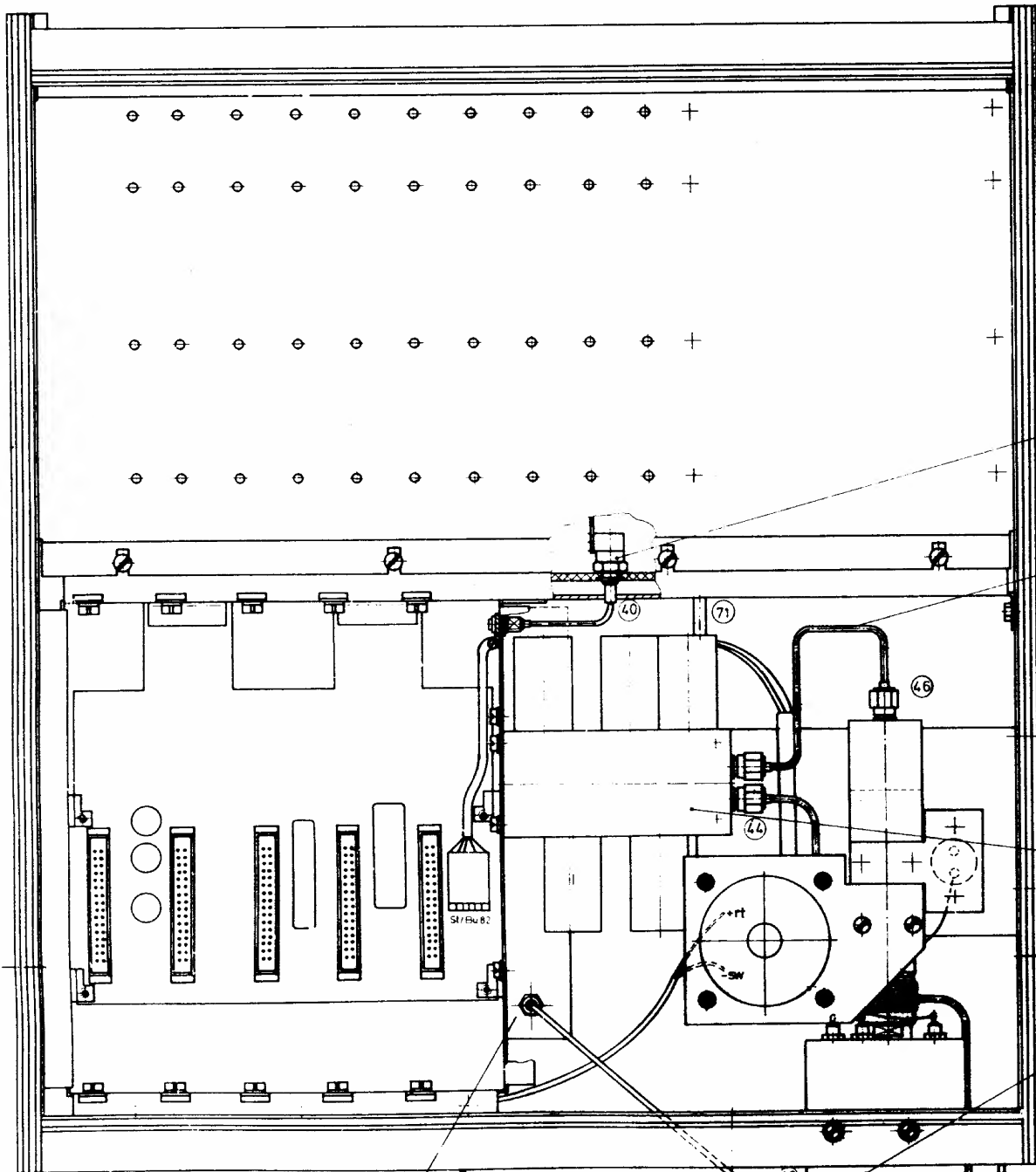

382 414  
706 407  
404 054

382 416  
382 436

M3x6 D  
701 640  
J 3,2 DII  
706 105

226 03  
M3x5 I  
701 144  
J 3,2 DII  
706 105

229 03  
M3x10  
701 147  
J 3,2 DI  
706 105

C

D

226 03  
M3x5 I N 84  
701 144  
J 3,2 DIN 197  
706 105

382 418

Frontplatte

36

43

382 415



855 007  
 430 115  
 405 071  
 705 323  
 M3 x 6 DIN  
 701 640  
 M3 x 5 C  
 701 156  
 J32 DIN  
 706 105

Schnitt A-B

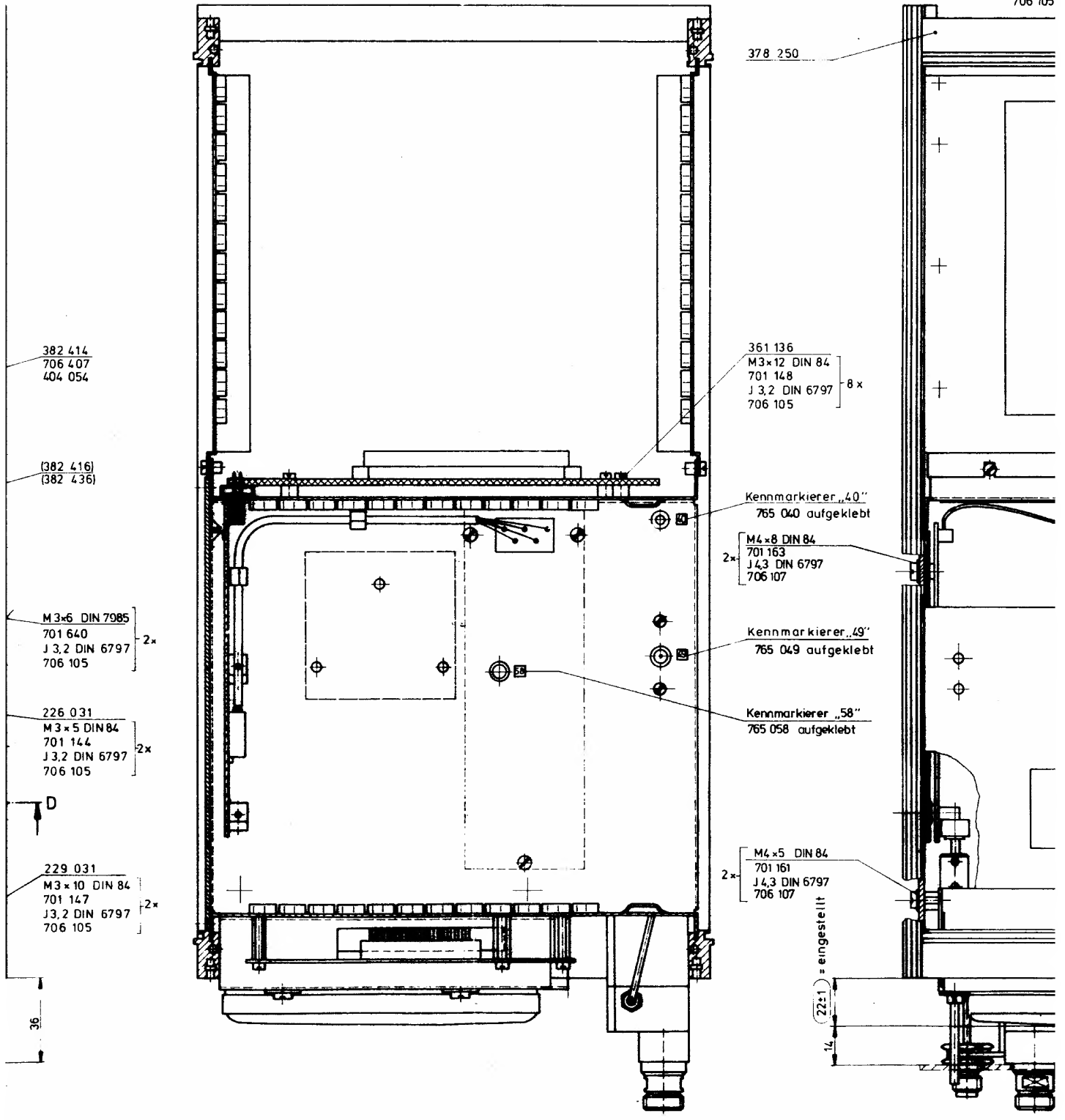

382 414  
 706 407  
 404 054

(382 416)  
 (382 436)

M3x6 DIN 7985  
 701 640  
 J 3,2 DIN 6797 } 2x  
 706 105

226 031  
 M3 x 5 DIN 84  
 701 144  
 J 3,2 DIN 6797 } 2x  
 706 105

229 031  
 M3 x 10 DIN 84  
 701 147  
 J 3,2 DIN 6797 } 2x  
 706 105

36

378 250

361 136  
 M3x12 DIN 84  
 701 148  
 J 3,2 DIN 6797 } 8x  
 706 105

Kennmarkierer „40“  
 765 040 aufgeklebt

M4x8 DIN 84  
 701 163  
 J 4,3 DIN 6797 } 2x  
 706 107

Kennmarkierer „49“  
 765 049 aufgeklebt

Kennmarkierer „58“  
 765 058 aufgeklebt

M4 x 5 DIN 84  
 701 161  
 J 4,3 DIN 6797 } 2x  
 706 107

(22±1) = eingestellt

14





- 855 007
- 430 115
- 405 071 (4x)
- 705 323 (2x) zwischen Dämpfungsglied u. LS-Montageplatte montiert
- M3 x 6 DIN 7985
- 701 640 (4x)
- M3 x 5 DIN 84
- 701 156 (2x)
- J 32 DIN 6797
- 706 105 (6x)

- M 3 x 5 DIN 84
- 701 144
- J 32 DIN 6797
- 706 105

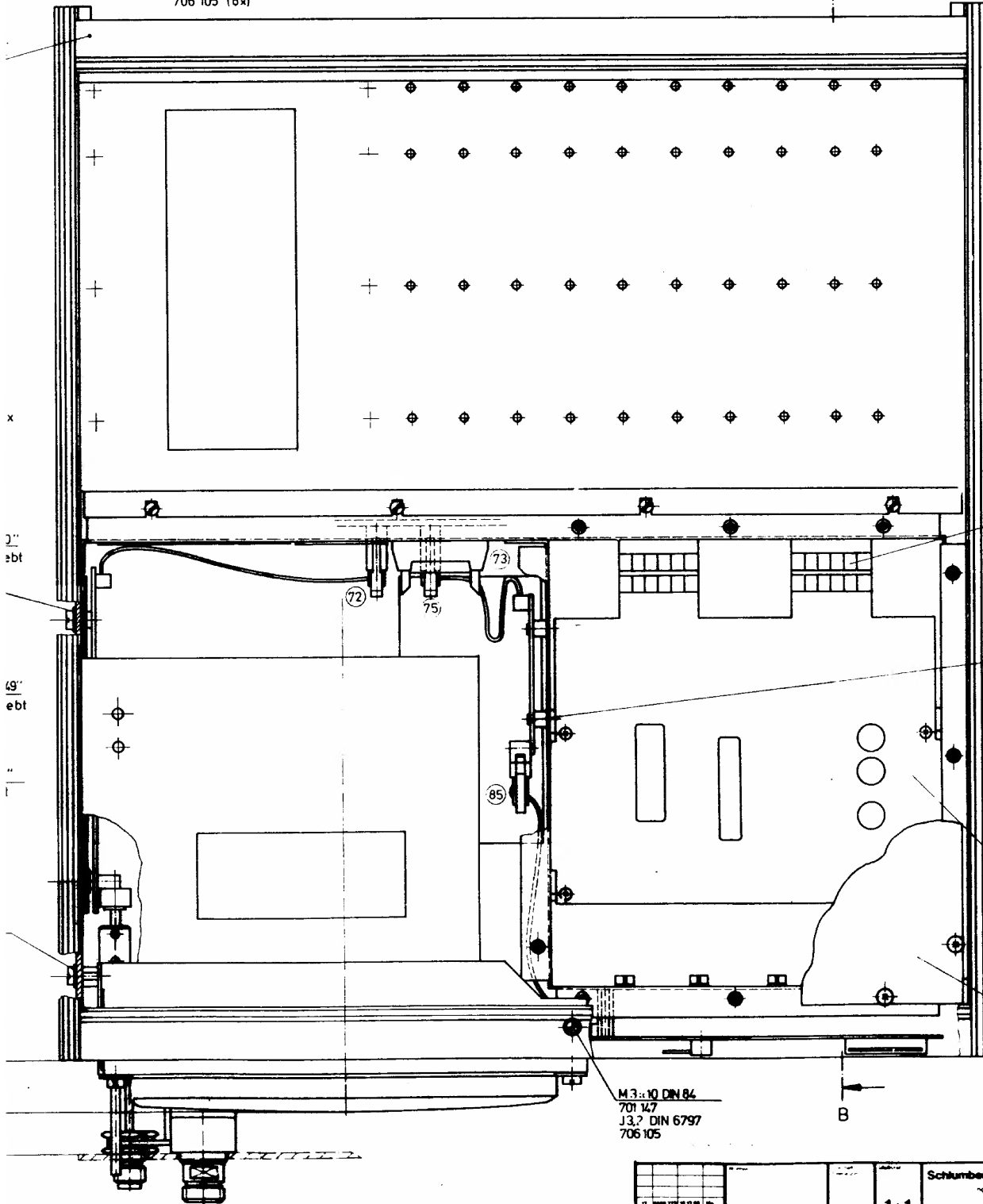

431 011 (0,6x)

- 361 485
- M 3 x 5 DIN 84
- 701 144
- J 32 DIN 6784
- 706 106

- 361 135
- M 2,5 x 3 DIN 7985
- 701 656
- (4x)

- 431 612
- M 3 x 6 DIN 7985
- 701 640 (14x)

- M 3 x 10 DIN 84
- 701 147
- J 32 DIN 6797
- 706 105

x  
2  
abt  
9  
ebt

Gerat

<table border="1"> <tr><td>17</td><td>...</td></tr> <tr><td>4</td><td>...</td></tr> <tr><td>6</td><td>...</td></tr> <tr><td>13</td><td>...</td></tr> <tr><td>17</td><td>...</td></tr> </table>		17	...	4	...	6	...	13	...	17	...	<table border="1"> <tr><td colspan="2">Schlumberger Meßgeräte GmbH</td></tr> <tr><td colspan="2">Högstrasser Straße 61a</td></tr> <tr><td colspan="2">80331 München 46</td></tr> <tr><td colspan="2">Rahmen kompl.</td></tr> <tr><td colspan="2">202 231</td></tr> </table>		Schlumberger Meßgeräte GmbH		Högstrasser Straße 61a		80331 München 46		Rahmen kompl.		202 231	
17	...																						
4	...																						
6	...																						
13	...																						
17	...																						
Schlumberger Meßgeräte GmbH																							
Högstrasser Straße 61a																							
80331 München 46																							
Rahmen kompl.																							
202 231																							
<table border="1"> <tr><td colspan="2">1:1</td></tr> <tr><td colspan="2">D 111, MÜNCH</td></tr> </table>		1:1		D 111, MÜNCH		<table border="1"> <tr><td colspan="2">202 231</td></tr> </table>		202 231															
1:1																							
D 111, MÜNCH																							
202 231																							

Farbkennzeichnung

834 901

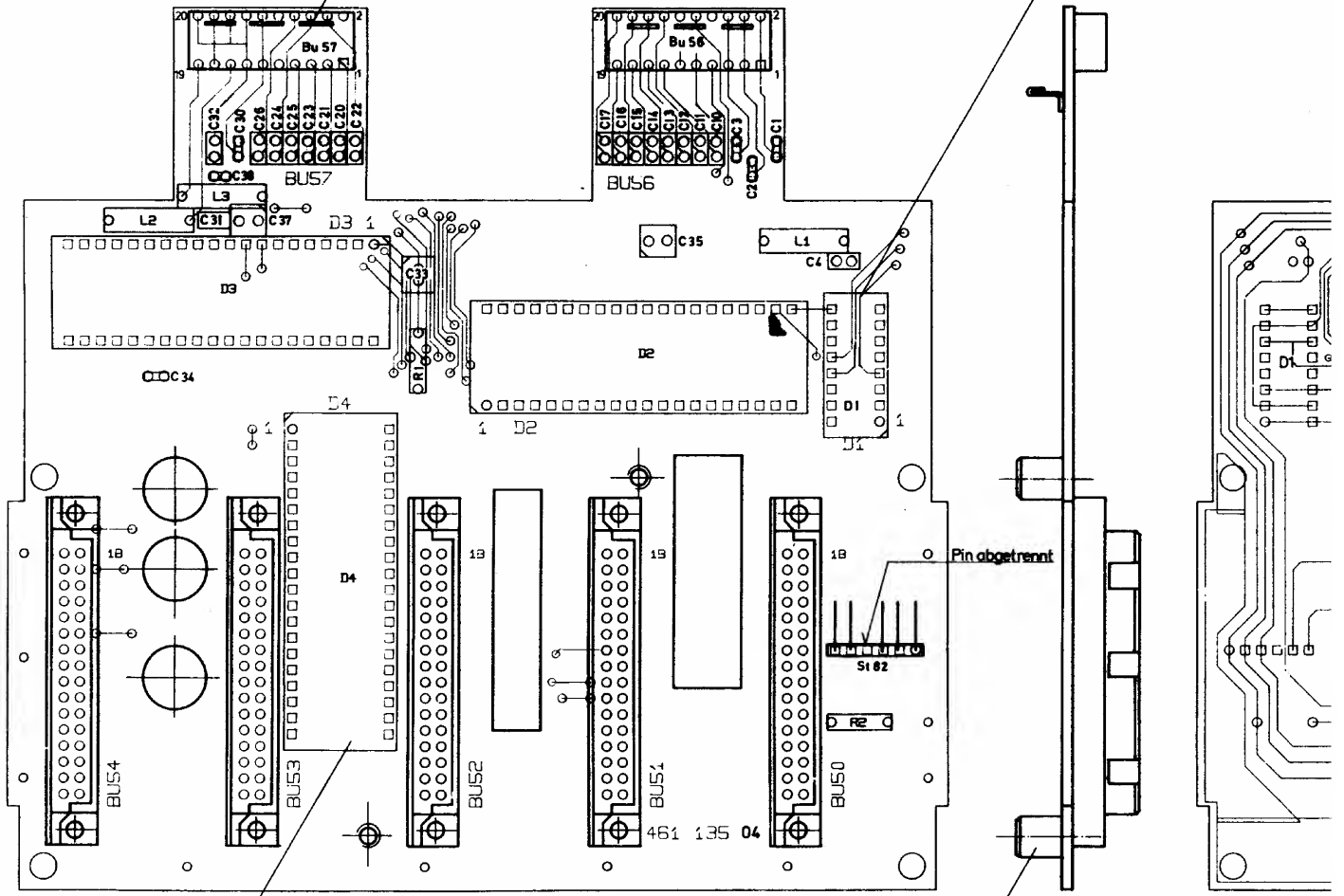

834 914 (3x)

423 069 (2x)  
genietet und weich gelötet



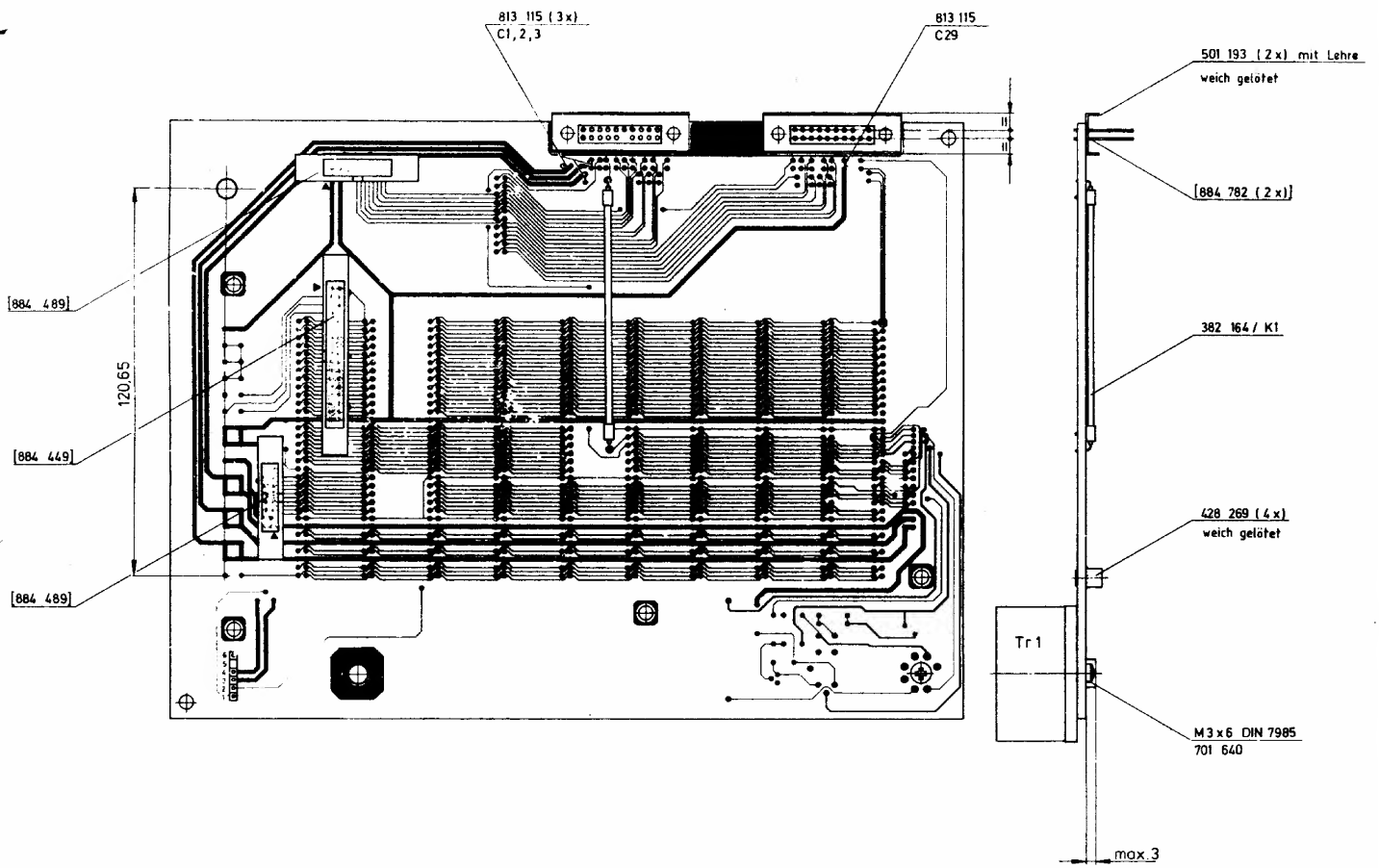





1	2	3	4	5	6	7	8
Pos. REF. NO.	Wert VALUE	Bezeichnung Schlumberger PART. NO.	Hersteller MANUFACT	Pos. REF. NO.	Wert VALUE	Bezeichnung Schlumberger PART. NO.	Hersteller MANUFACT
1	RF-MOTHERBOARD	361 135	SCHL				
	hierzu see	361 135 Sa					
1	AF-MOTHERBOARD	361 136	SCHL				
	hierzu see	361 136 Sa					
K 40	HF-Kabel RF-CABLE	382 414	SCHL				
K 44	HF-Kabel RF-CABLE	382 415	SCHL				
K 46	HF-Kabel RF-CABLE	382 416	SCHL				
K 48	HF-Kabel RF-CABLE	382 418	SCHL				

07				Schlumberger Meßgeräte GmbH Ingotädter Straße 67 a 8000 München 46			<b>Schalteilliste</b> EL. PARTS LIST		Liste besteht LIST CONSISTS		
06			Benennung DESCRIPTION							Rahmen, komplett	
06							Bezeichnung Schlumberger PART. NO.		202 231 Sa		Blatt SHEETS
04							Hierzu Schaltplan BEE CIRCUIT DIAGRAM		201 231 S		Blatt Nr. SHEET NO.  1
03							Gerät:		4031		
02				1988	Tag DATE	Name NAME					
01				beachr.	11.3.	Staffler					
Aus- gabe ISSUE	Änd.-Mittg. Nr. MODIFIC. NO.	Tag DATE	Name NAME	bearb. 99pr.		<i>Staffler</i>					

Diese Zeichnung ist unser Eigentum. Vervielfältigung, unbefugte Verwertung, Mitteilung an andere ist strafbar und schadenersatzpflichtig.







1	2	3	4	5	6	7	8
Pos. REF. NO.	Wert VALUE	Bezeichnung Schlumberger PART. NO.	Hersteller MANUFACT	Pos. REF. NO.	Wert VALUE	Bezeichnung Schlumberger PART. NO.	Hersteller MANUFACT
Bu 60		884 520	SIE				
Bu 64		884 520	SIE				
Bu 67		884 520	SIE				
Bu 69		884 520	SIE				
Bu 76		884 529	SIE				
C 1	10 nF $\pm 10\%$ 50 V-	813 115	VIT				
C 2	10 nF $\pm 10\%$ 50 V-	813 115	VIT	C 29	10 nF $\pm 10\%$ 50 V-	813 115	VIT
C 3	10 nF $\pm 10\%$ 50 V-	813 115	VIT				
				C 32	100 $\mu$ F EB 20 HD 310 G	814 095	RÖD
				G1 1	1 N 4148	830 240	ITT
				K 1	HF-Kabel	382 164	SCHL
				K 74	Kabelbaum	384 743	SCHL

07				Schlumberger Maßgeräte GmbH Ingoletztcher Straße 67a 8000 München 46			Schaltteilliste EL. PARTS LIST		Liste besteht LIST CONSISTS			
06			Benennung DESCRIPTION						Bestückte Leiterplatte AF-MOTHERBOARD		2	
05							Typ:		AF-MOTHERBOARD		SHEETS	
04											Blatt Nr. SHEET NO	
03	3088.6	13.1.86	Sh	1986	Tag DATE	Name NAME	Bezeichnung Schlumberger PART. NO.		361 136 Sa			
02	7088.34	16.3.87	Lei	gezeichnet	20.6.86	Dietrich	Heraus Schaltungen SEE CIRCUIT DIAGRAM		361 136 S			
01	6088.50	7.11.86	Di	gezeichnet			Bezeichnung Schlumberger PART. NO.		361 136 S			
00							Bezeichnung Schlumberger PART. NO.		4031			
Ausgabe ISSUE	Ant.-Menge NO.	Tag DATE	Name NAME	gezeichnet DRAWN								

Diese Zeichnung ist unser Eigentum. Vervielfältigung, unbefugte Vervielfältigung, Mitteilung an andere ist strafbar und schadenersatzpflichtig.

1	2	3	4	5	6	7	8
Pos. REF. NO.	Wert VALUE	Bezeichnung Schlumberger PART. NO.	Hersteller MANUFACT	Pos. REF. NO.	Wert VALUE	Bezeichnung Schlumberger PART. NO.	Hersteller MANUFACT
R 1	2,74 kΩ ± 1%	802 042	RÖD	T 1	8C 550 B	832 127	TEX
R 2	221 Ω ± 1%	802 029	RÖD				
R 3	4,75 kΩ ± 1%	802 045	RÖD				
R 4	10 kΩ ± 1%	802 049	RÖD				
R 5	18,2 Ω ± 1%	802 016	RÖD				
R 6	18,2 Ω ± 1%	802 016	RÖD	Tr 1	RÜP 845 M	825 015	PIK
R 7	10 kΩ ± 1%	802 049	RÖD				
RTs 1	Typ RS-12 V	843 040	MATSU				
St 56		884 782					
St 57		884 782					
St 70		884 538					
St 71		884 783					
St 72		884 489					
St 75		884 449					

07				Schlumberger Meßgeräte GmbH Ingoistädter Straße 67 a 8000 München 46			Schalttailliste EL. PARTS LIST		Liste besteht LIST CONSISTS
06									
05				Typ		361 136 8a	Blatt Nr. SHEET NO.		
04				Bezeichnung Schlumberger PART. NO.				361 136 8	2
03				Matsu Schaltplan SEE CIRCUIT DIAGRAM		361 136 8	2		
02				Gest.: 4031					
01	8088,161	19.9.88	Kr.	Tag DATE	Name NAME				
	6088,50	7.11.86	Di	gestr.: 26.8.86	Kernsch				
Ausgabe ISSUE	Änd.-Nr. MODIF. NO.	Tag DATE	Name NAME	gezeichnet DRAWN	geprüft CHKD.				

Diese Zeichnung ist unser Eigentum. Vervielfältigung, unbefugte Verwertung, Mitteilung an andere ist strafbar und schadenersatzpflichtig.

(von Bauteilseite)

- 1\* ABST.BOLZEN AM3\*50
- 1\* ABST.BOLZEN AM3\*25
- X1
- LP

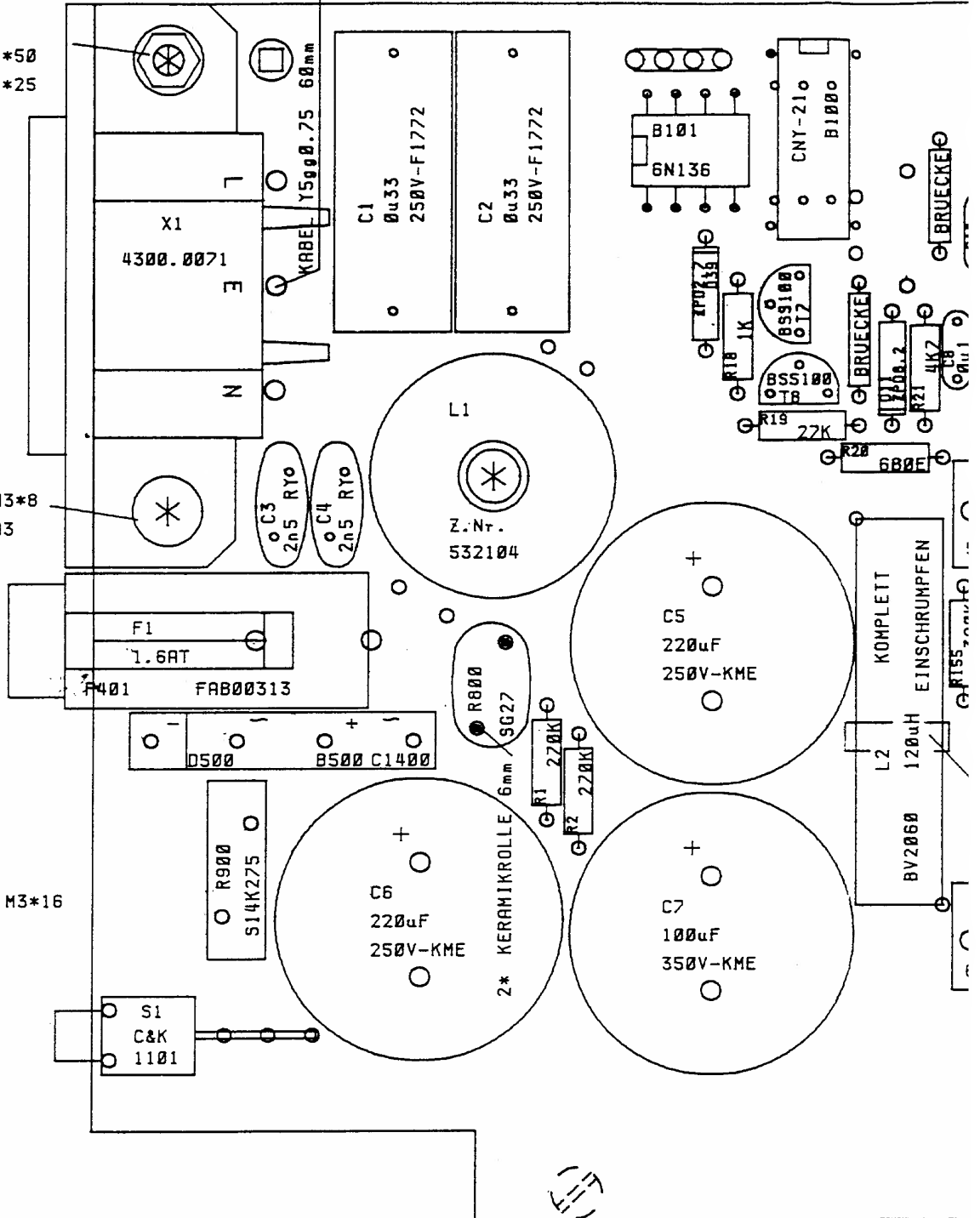

- 1\* LIN.SCHR D7985 M3\*8
- 1\* FED.SCH. D137 A3

**MONTAGE L1**

- (von Bauteilseite)
- 1\* PLA.SCHR D85 M3\*16
  - L1
  - LP

**MONTAGE T2**

- (von vorne)
- 1\* PLA.SCHR D85 M3\*8
  - T2
  - 1\* ISOLIERUNG 74291050
  - KUEHLK.

**MONTAGE T3**

- (von vorne)
- 1\* LIN.SCHR D7985 M3\*12
  - 1\* UNT.SCH. D125 A3.2
  - 1\* ISOLIER-NIPPEL KU6-651
  - T3
  - 1\* ISOLIERUNG 74291059
  - KUEHLK.

**MONTAGE HV-KK**

- (von unten)
- 2\* ZTL.SCHR D84 M2.5\*8
  - 2\* ZAHNSCH. D6797 A2.5
  - LP
  - 1\* KUEHLK. Z.Nr.532016

LEITER PLATTE LACKIEREN!

E
F
ZUST

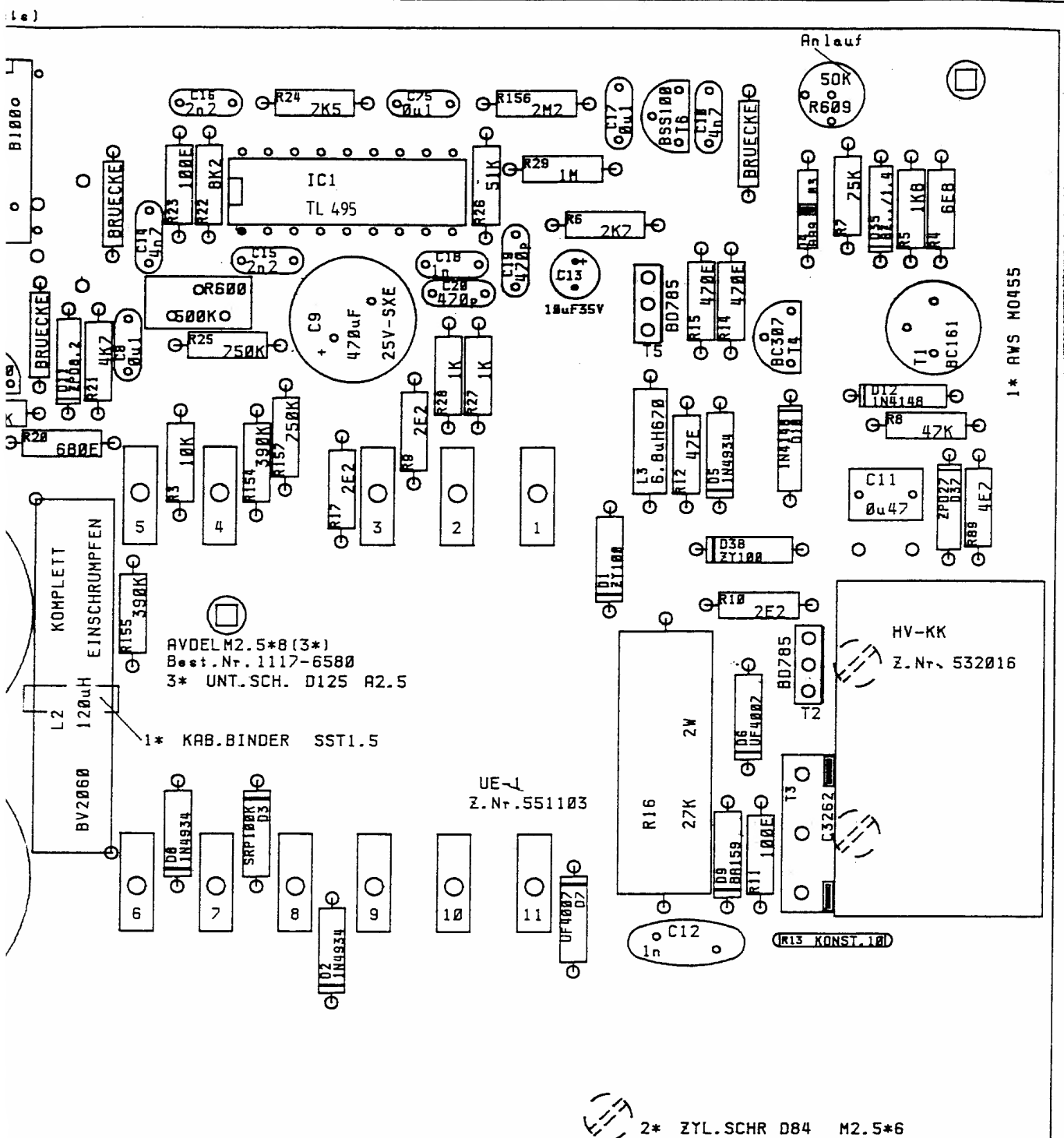

SMG-4031		110V 220V	10.5V- 32V DC	MASSTAB 2:1					
		Z.Nr. 551401F							
5*8	E	Neuz.	31.03.88	Jan	DATUM	NAME	+5.2V 8A +15V 3.5A -15V 1.5A	HV-LP	
5	F	R157 D38 DREU	26.05.88	Se.	BEARB. 24.08.87	Buckenm.			
		T1/BC161			GEPR.				
16									
RENI					MGV		LP.Z.Nr. 551301D		
	ZUST.	ÄNDERUNG	DATUM	NAME	4031 POWER SUPPLY 204 031 LP2		(E.r.-A.)		
								BLATT	B1.

 AVDEL (7\*)  
 M 2.5\*8  
 7\* UNT.SCH. D125 A2.5  
 dazwischen legen

1\* AWS M0455

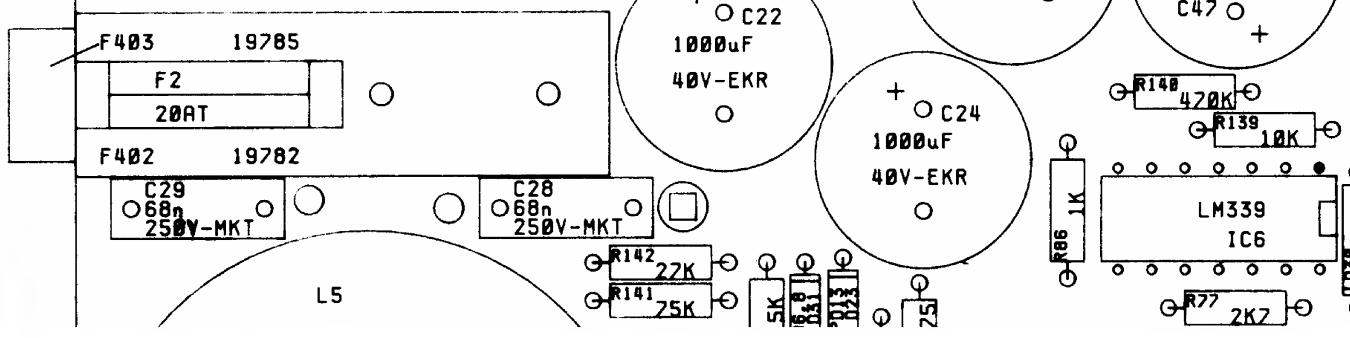
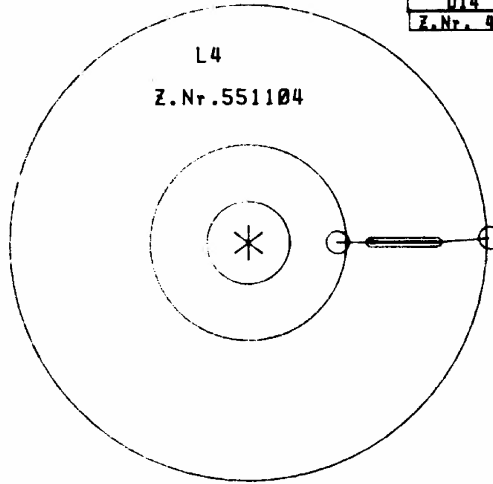
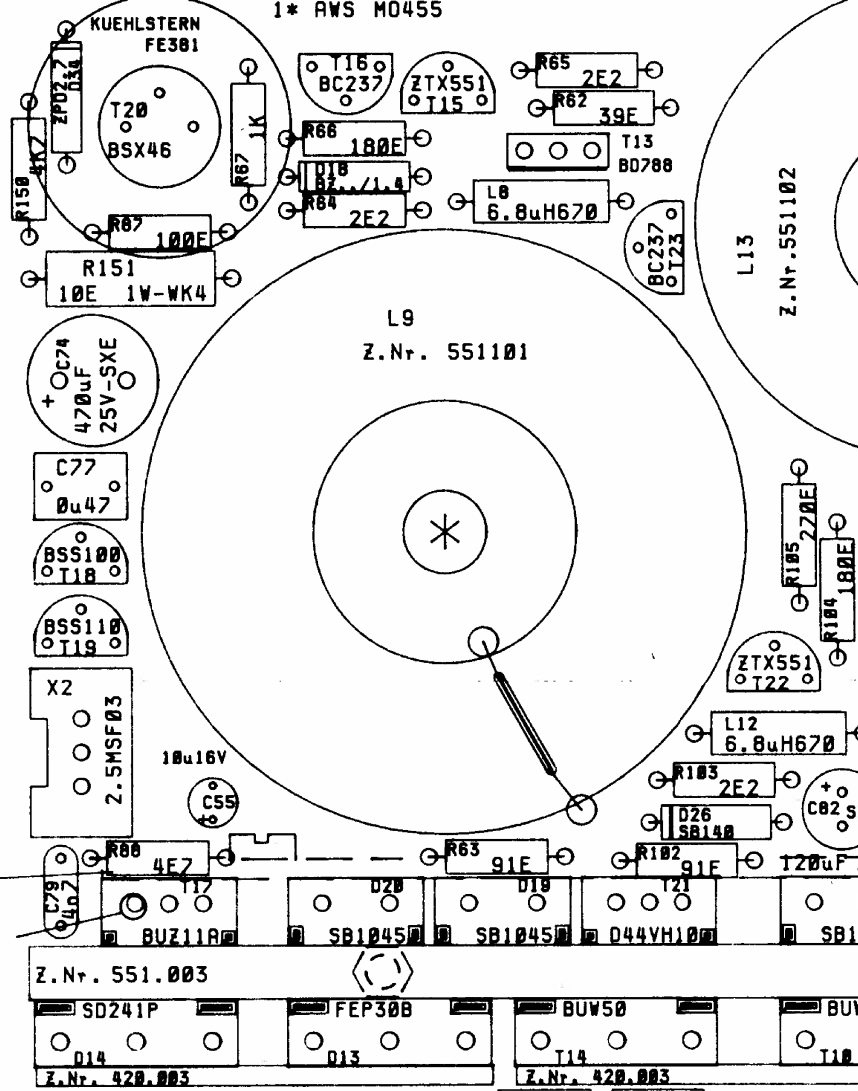



### MONTAGE ZENTRIERUNG

(von aussen)

- 1\* ZENTR. Z.Nr.551008
- 1\* CHASSIS Z.Nr.551002
- 1\* FED.RING D127 A6.5
- 1\* MUTTER D934 M6M:

C83:

Anschlüsse mit  
Schrumpfschlauch  
isolieren und mit  
Silikonkleber  
auf LP sichern.

STECKER:

Von LOETSEITE  
montieren!

### MONTAGE L4, L7, L13

(von Bauteilseite)

- 3\* ZYL.SCHR D84M: M3\*10
- 3\* UNT.SCH. D9021 A3.2
- 3\* HALTERUNG 74D254  
L4, L7, L13
- 3\* ISO.SCH. Z.Nr.524.005  
LP

### MONTAGE L5

(von Bauteilseite)

- 1\* ZYL.SCHR D84M: M3\*35
- 1\* FED.SCH. D137 A3.2
- 1\* ISOLIER-NIPPEL 61B550  
L5  
LP

### MONTAGE DIODEN-KW

(von Loetseite)

- 2\* ZYL.SCHR D84 M2.5\*5  
LP
- 2\* ABST.BOLZEN AM2.5\*5  
KW

### MONTAGE DIODEN-KK

(von vorne)

- 2\* ZYL.SCHR D84 M3\*8
- 2\* FED.RING D127 A3.2
- DIODEN-KW Z.Nr. 551003
- 1\* KUEHLK. Z.Nr.551004

### MONTAGE D16, Ty1

(von vorne)

- 1\* ZYL.SCHR D84 M2.5\*10
- 1\* FED.RING D127 A2.5
- 1\* HALTERUNG 420002  
D16, Ty1  
ISOLIERUNG  
DIODEN-KW Z.Nr. 551003

### MONTAGE L9

(von Bauteilseite)

- 1\* ZYL.SCHR D84M: M3\*18
- 1\* UNT.SCH. D9021 A3.2
- 1\* HALTERUNG 74D258  
L9
- 1\* ISO.SCH. Z.Nr.524.005  
LP

### MONTAGE LUEFTER

(von vorne/aussen)

- 4\* LIS.SCHR D966 M4\*12
- 1\* FRONTPL. Z.Nr.551.000
- 1\* LUEFTER 8312  
(nach aussen blasend)
- 4\* UNT.SCH. D125 A4.3
- 4\* FED.RING D127 A4.3
- 1\* MUTTER D934 M4

### MONTAGE D13, D14, D19, D20, D27,

(von vorne) T10, T14, T17, T21

- 2\* LIN.SCHR D7985 M2.5\*20
- 2\* FED.SCH. D137 A2.5
- 1\* HALTER Z.Nr.551006
- DIODEN, TRANSISTOREN
- 1\* ISOLIER. Z.Nr.551013
- 1\* KUEHLW. Z.Nr.551003
- 1\* ISOLIER. Z.Nr.551004
- DIODEN, TRANSISTOREN
- 2\* HALTER Z.Nr.420003

### MONTAGE Ty2

(von vorne)

- 1\* LIN.SCHR D7985 M3\*8
- 1\* UNT.SCH. D125 A3.2
- 1\* ISOLIERUNG KU6-650  
TY2
- 1\* ISOLIERUNG 74291054
- DIODEN-KW Z.Nr. 551.003

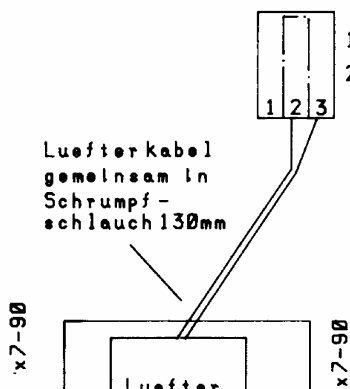
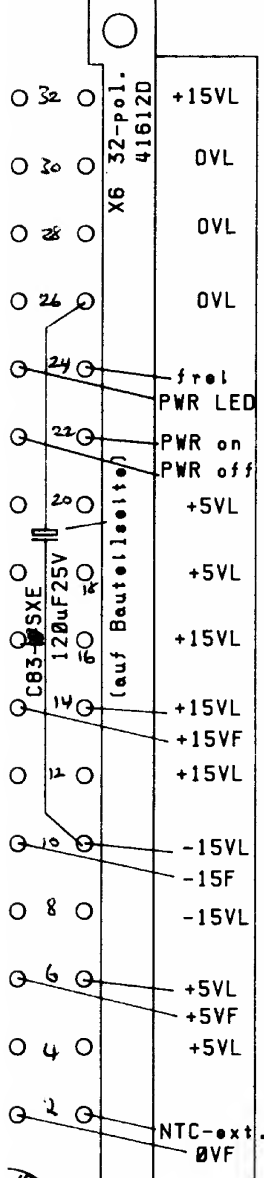

- 1\* STECKER 2.5MBC03
- 2\* KONTAKT FC01L

### DAZU

- 1\* U-WAND Z.Nr.551001
- 1\* GRIFF Z.Nr.551011
- 1\* GR.ZUB. Z.Nr.551.012
- 1\* ISOLIERUNG 551009 fuer HV-LP



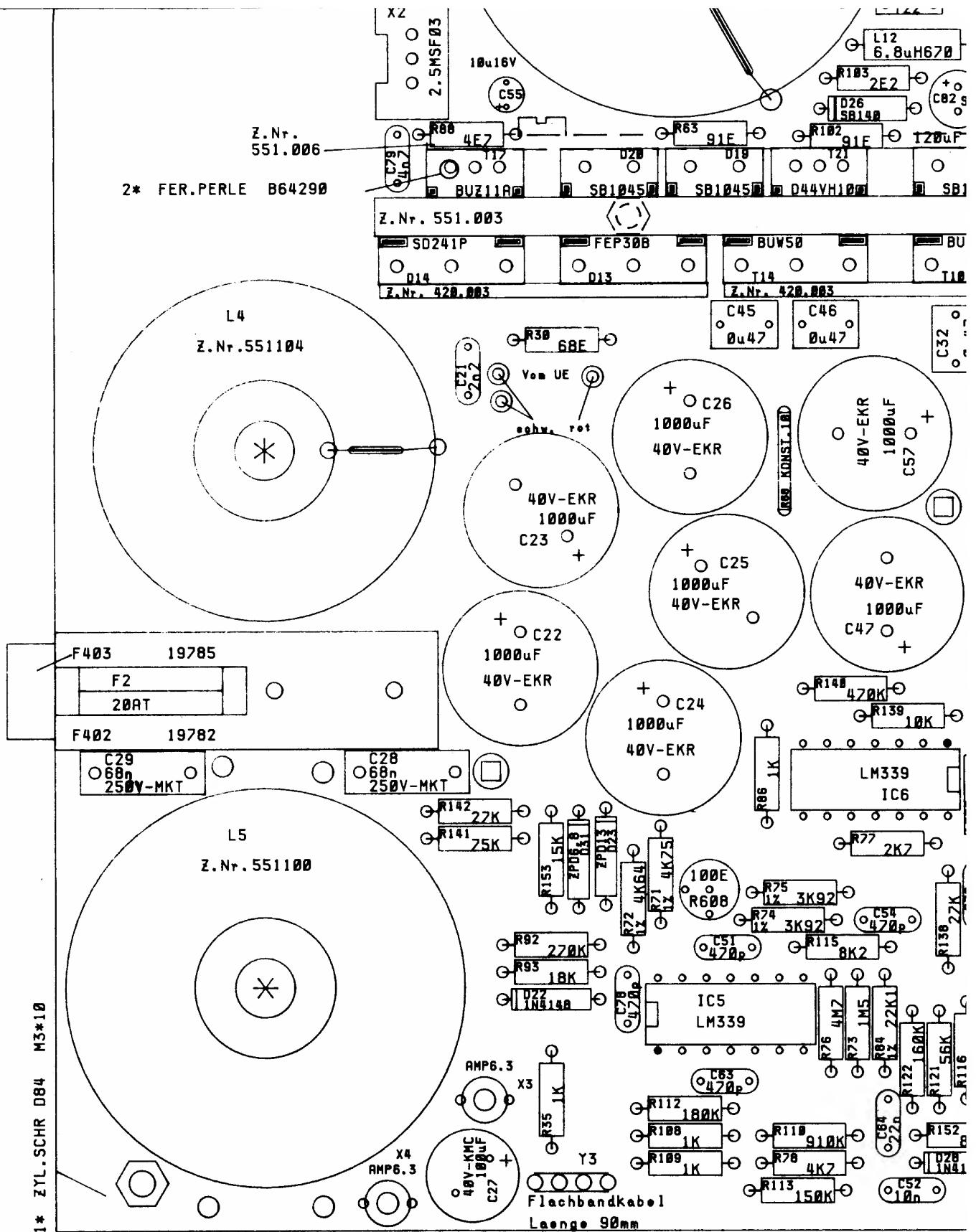

**PRUEFHINWEIS**

U<sub>emIn</sub> = 176V ~ 94V ~  
 ABSCHALTTEMPERATUR (NTC) = 90-100°C  
 PRIMAERSTROMBEGRENZUNG AUF 6A EINSTELLEN

TASTVERHAELTNISBEGRENZUNG AUF 33-35V EINSTELL  
 STROMBEGRENZUNG +15V (gerade Kennlinie)  
 LUEFTERSPANNUNG BEIM KALTEN NG = 6-8V  
 BEI 50°C KK-TEMPERATUR ERREICHT LUEFTER VOLLE

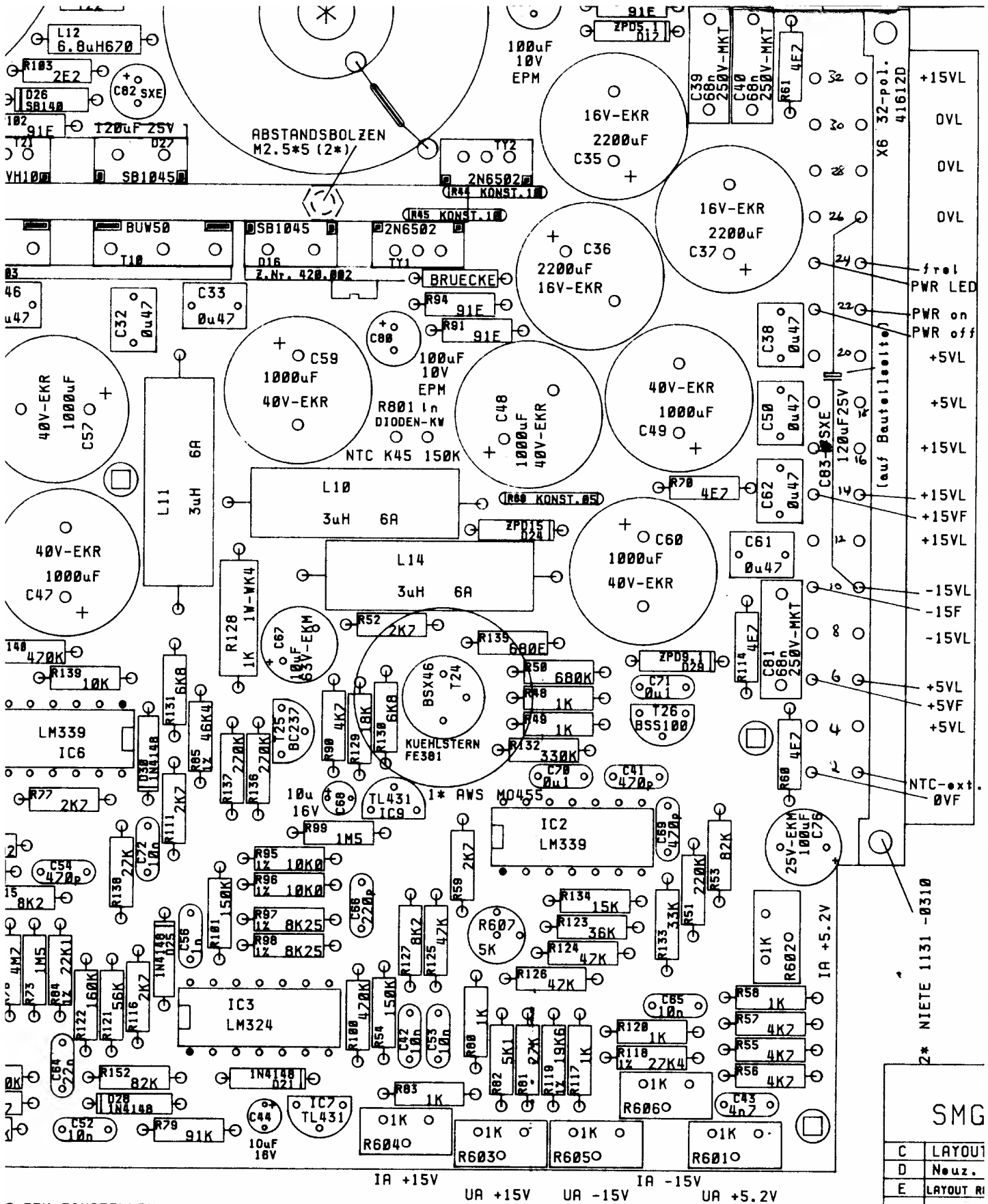

3-35V EINSTELLEN  
 null/nul)  
 = 6-8V  
 LUEFTER VOLLE DREHZAHL

FP WERDEN VOR MONTAGE AN SMG GESCHICKT  
 ZUR EINPREGUNG EINER SERIENNUMMER!

SMG

C	LAYOUT
D	Neuz.
E	LAYOUT RI
ZUST.	ÄNDER

2\* NIETE 1131 -0310

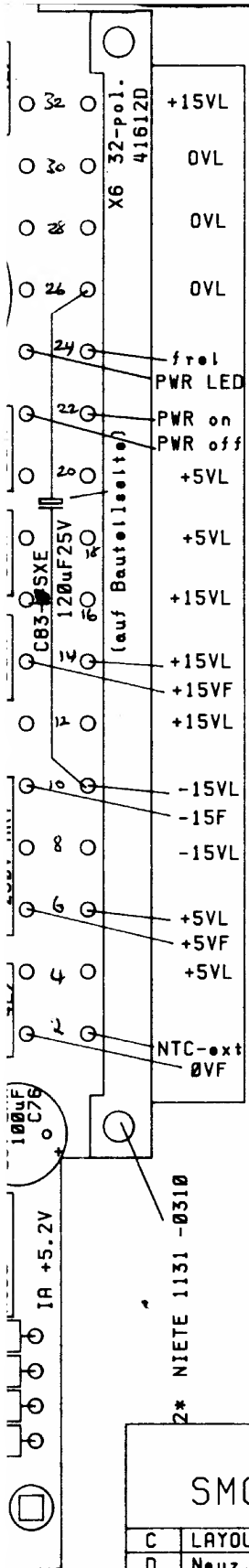

- (von Loetstelle)
- 2\* ZYL.SCHR D84 M2.5\*5 LP
  - 2\* ABST.BOLZEN AM2.5\*5 KW

- MONTAGE DIODEN-KK**  
(von vorne)
- 2\* ZYL.SCHR D84 M3\*8
  - 2\* FED.RING D127 A3.2
  - DIODEN-KW Z.Nr. 551003
  - 1\* KUEHLK. Z.Nr.551004

- MONTAGE D16, Ty1**  
(von vorne)
- 1\* ZYL.SCHR D84 M2.5\*10
  - 1\* FED.RING D127 A2.5
  - 1\* HALTERUNG 420002
  - D16, Ty1
  - ISOLIERUNG
  - DIODEN-KW Z.Nr. 551003

- MONTAGE D13, D14, D19, D20, D27,**  
(von vorne) T10, T14, T17, T21
- 2\* LIN.SCHR D7985 M2.5\*20
  - 2\* FED.SCH. D137 A2.5
  - 1\* HALTER Z.Nr.551006
  - DIODEN, TRANSISTOREN
  - 1\* ISOLIER. Z.Nr.551013
  - 1\* KUEHLW. Z.Nr.551003
  - 1\* ISOLIER. Z.Nr.551004
  - DIODEN, TRANSISTOREN
  - 2\* HALTER Z.Nr.420003

- MONTAGE Ty2**  
(von vorne)
- 1\* LIN.SCHR D7985 M3\*8
  - 1\* UNT.SCH. D125 A3.2
  - 1\* ISOLIERUNG KU6-650
  - TY2
  - 1\* ISOLIERUNG 74291054
  - DIODEN-KW Z.Nr. 551.003

- 1\* STECKER 2.5MBC03
- 2\* KONTAKT FC01L

Luefterkabel  
gemeinsam in  
Schrumpfschlauch 130mm

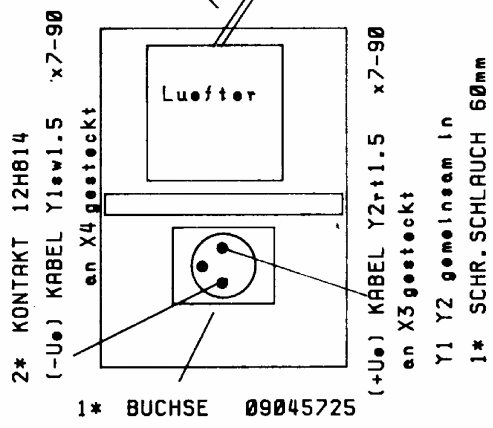

**DAZU**

- 1\* U-WAND Z.Nr.551001
- 1\* GRIFF Z.Nr.551011
- 1\* GR.ZUB. Z.Nr.551.012
- 1\* ISOLIERUNG 551009 fuer HV-LP
- 1\* ABDECK. Z.Nr.551010
- 1\* BEST.LP Z.Nr.551401

SMG-4031		110V AC	10.5V-	MASSTAB 2:1			
		220V AC	32V DC	Z.Nr. 551400E			
C	LAYOUT	04.01.00	Se.	DATUM	NAME	+5.2V 8A +15V 3.5A -15V 1.5A	STECKER -LP
D	Neuz.	20.03.00	Jan	BEARB. 24.08.07	Semmler		
E	LAYOUT R02 DAZU	25.05.00		GEPR.			
				NORM			
				MGV		LP.Z.Nr. 551300D	
ZUST.	ÄNDERUNG	DATUM	NAME	4031 POWER SUPPLY 204 031 LP1		(Ere.d.)	





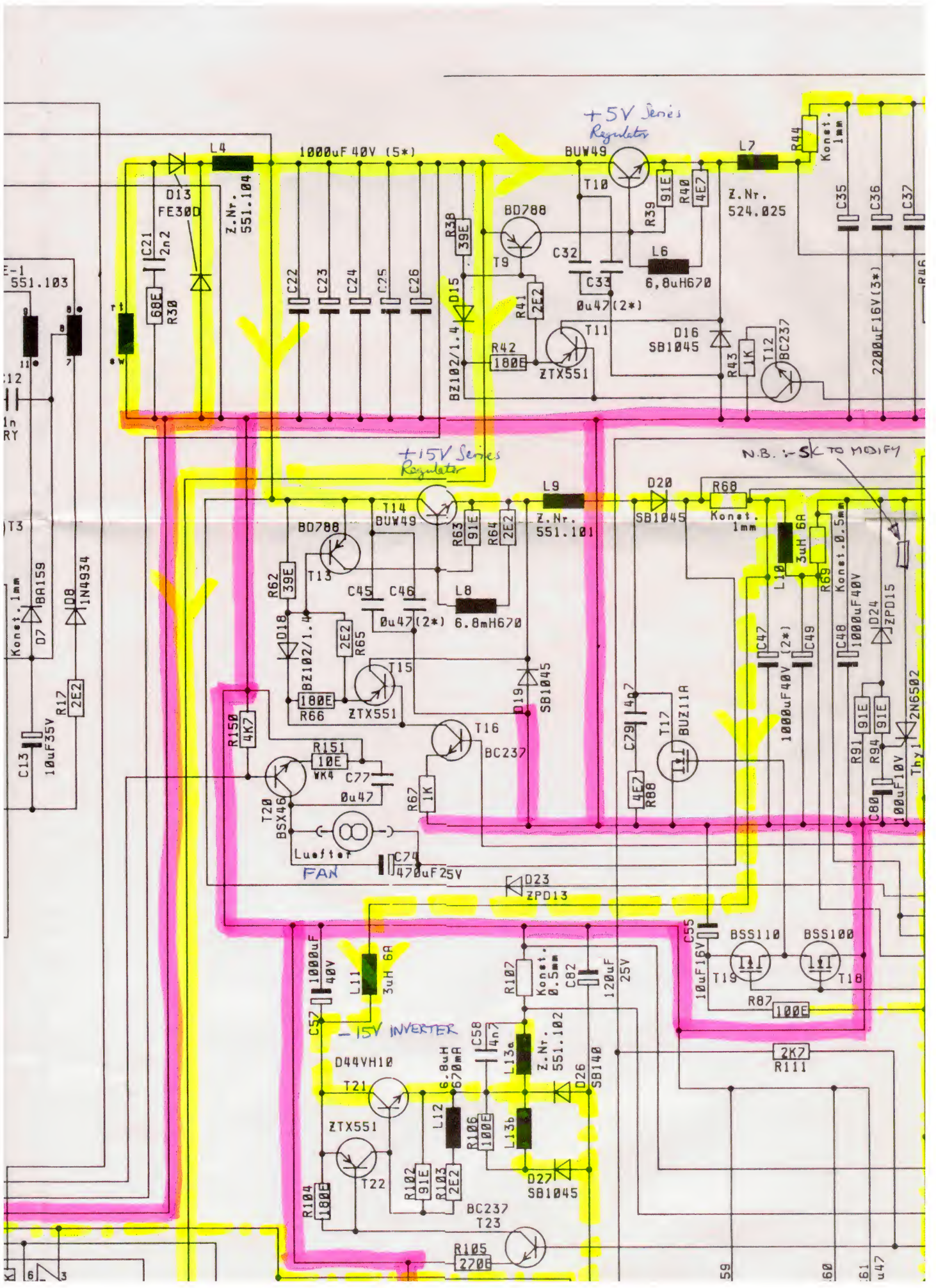

+5V Series Regulator

+15V Series Regulator

-15V INVERTER

N.B. - SK TO MODIFY

F-1  
551.103

T3

T3

61  
u47

Z.Nr.  
551.104

Z.Nr.  
524.025

Z.Nr.  
551.101

Z.Nr.  
551.102

C57  
1000uF  
40V

D44VH10

R104  
180E

R105  
270E

T21

T22

T23

L4

D13  
FE300

C21  
2n2

R30  
68E

C22

C23

C24

C25

C26

D15

R38  
39E

T9

R41  
2E2

R42  
180E

T10

T11

T12

T13

T14

T15

T16

T17

T18

T19

T20

T21

T22

T23

T24

T25

L6

L7

L8

L9

L10

L11

L12

L13a

L13b

L14

L15

L16

L17

L18

L19

L20

L21

L22

L23

L24

L25

L26

L27

L28

L29

L30

L31

L32

L33

L34

R39

R40

R41

R42

R43

R44

R62

R63

R64

R65

R66

R67

R68

R87

R88

R91

R92

R93

R94

R102

R103

R104

R105

R106

R107

R108

R109

R110

R111

R112

C32

C33

C34

C35

C36

C37

C45

C46

C47

C48

C49

C50

C51

C52

C53

C54

C55

C56

C57

C58

C59

C60

C61

C62

C63

C64

C65

C66

C67

C68

D16

D17

D18

D19

D20

D21

D22

D23

D24

D25

D26

D27

D28

D29

D30

D31

D32

D33

D34

D35

D36

D37

D38

D39

D40

D41

D42

D43

D44

D45

K1

K2

K3

K4

K5

K6

K7

K8

K9

K10

K11

K12

K13

K14

K15

K16

K17

K18

K19

K20

K21

K22

K23

K24

K25

K26

K27

K28

K29

K30

BUW49

BUZ102/1.4

BUZ111A

BUZ112

BUZ113

BUZ114

BUZ115

BUZ116

BUZ117

BUZ118

BUZ119

BUZ120

BUZ121

BUZ122

BUZ123

BUZ124

BUZ125

BUZ126

BUZ127

BUZ128

BUZ129

BUZ130

BUZ131

BUZ132

BUZ133

BUZ134

BUZ135

BUZ136

BUZ137

BUZ138

BC237

BC238

BC239

BC240

BC241

BC242

BC243

BC244

BC245

BC246

BC247

BC248

BC249

BC250

BC251

BC252

BC253

BC254

BC255

BC256

BC257

BC258

BC259

BC260

BC261

BC262

BC263

BC264

BC265

BC266

BSX46

BSX47

BSX48

BSX49

BSX50

BSX51

BSX52

BSX53

BSX54

BSX55

BSX56

BSX57

BSX58

BSX59

BSX60

BSX61

BSX62

BSX63

BSX64

BSX65

BSX66

BSX67

BSX68

BSX69

BSX70

BSX71

BSX72

BSX73

BSX74

BSX75

BZ102/1.4

BZ103/1.4

BZ104/1.4

BZ105/1.4

BZ106/1.4

BZ107/1.4

BZ108/1.4

BZ109/1.4

BZ110/1.4

BZ111/1.4

BZ112/1.4

BZ113/1.4

BZ114/1.4

BZ115/1.4

BZ116/1.4

BZ117/1.4

BZ118/1.4

BZ119/1.4

BZ120/1.4

BZ121/1.4

BZ122/1.4

BZ123/1.4

BZ124/1.4

BZ125/1.4

BZ126/1.4

BZ127/1.4

BZ128/1.4

BZ129/1.4

BZ130/1.4

BZ131/1.4

BUZ102/1.4

BUZ103/1.4







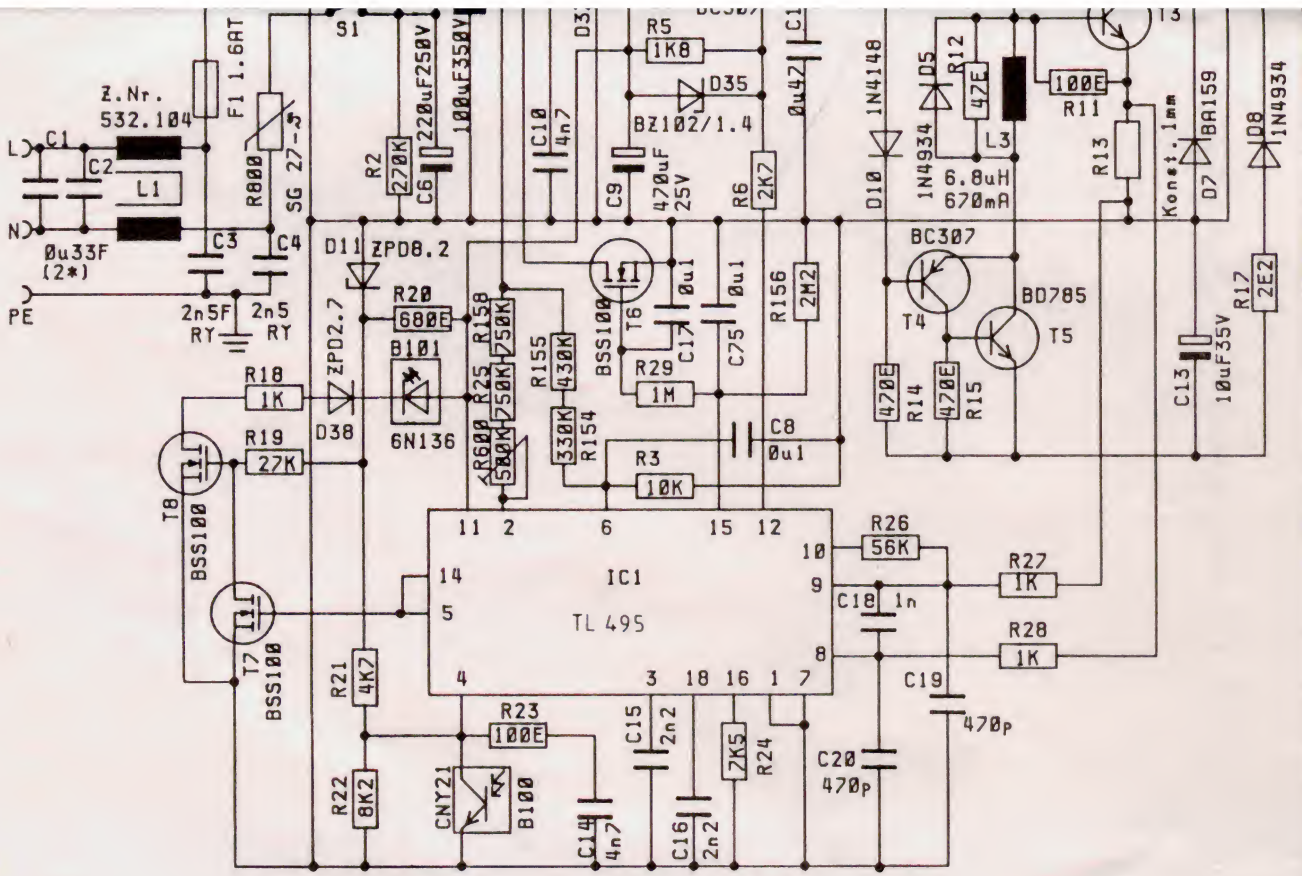

TO RUN FREE-STANDING:  
 SHORT 22A TO 22C TO  
 SIMULATE ON SWITCH.

NOTE: WILL NOT SUPPLY  
 CURRENT FREE-STANDING.

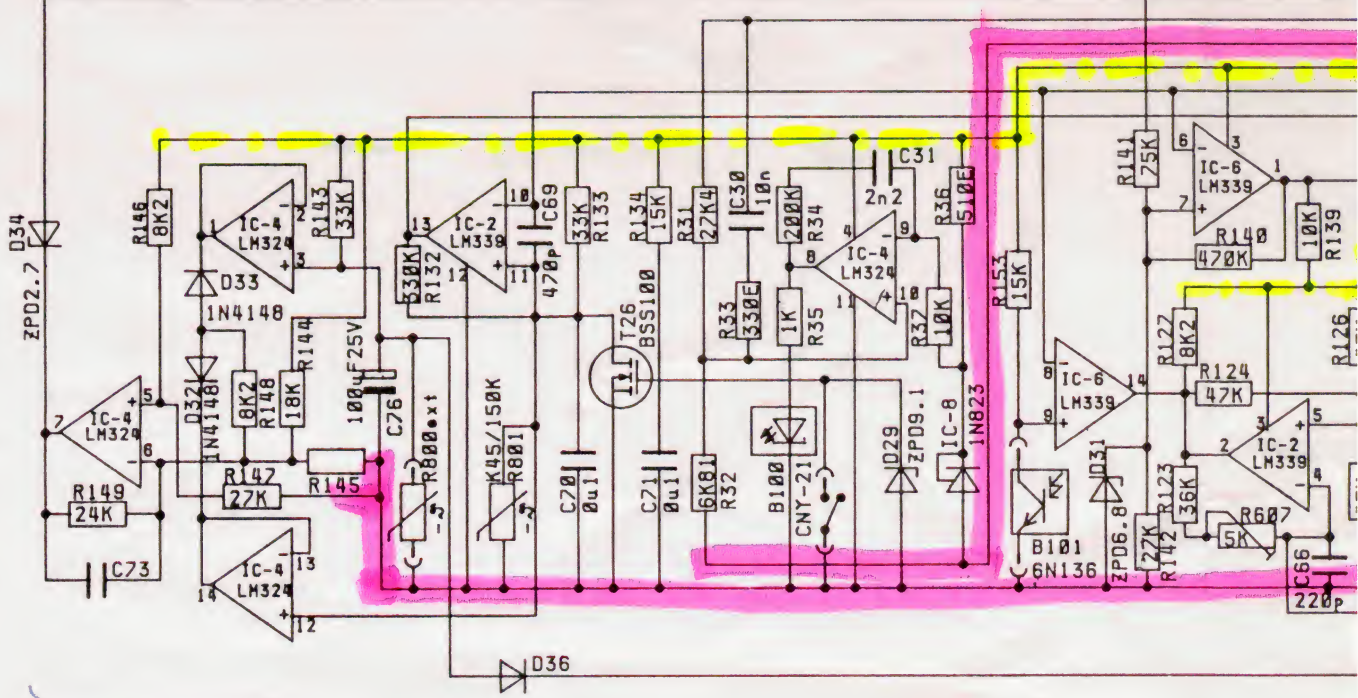

FAN SPEED CONTROL/DRIVE



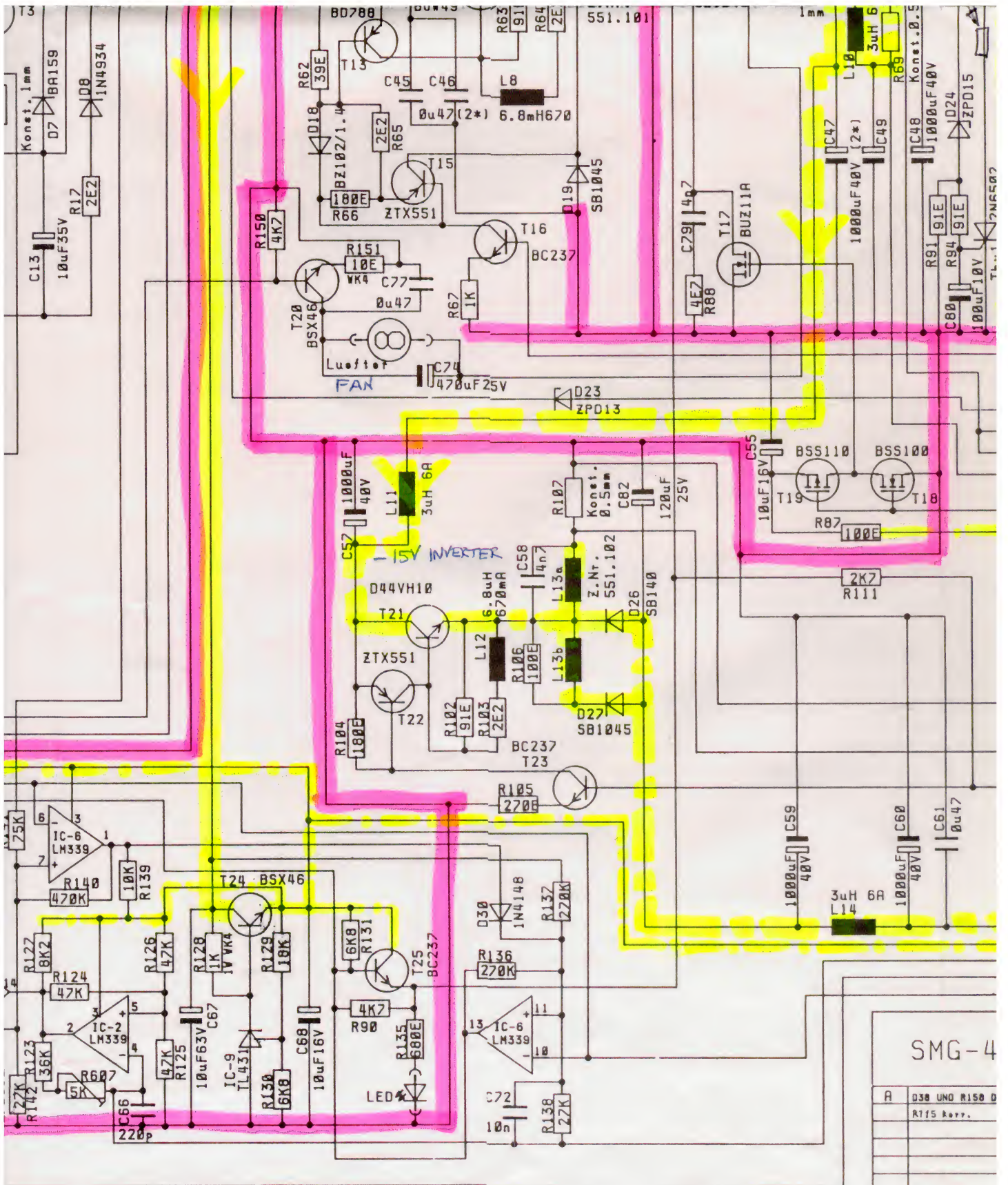

Luem REF-SUPPLY

SMG-4

A	D30 UND R150 D
	R115 Rev.
ZUST.	ÄNDERUNG



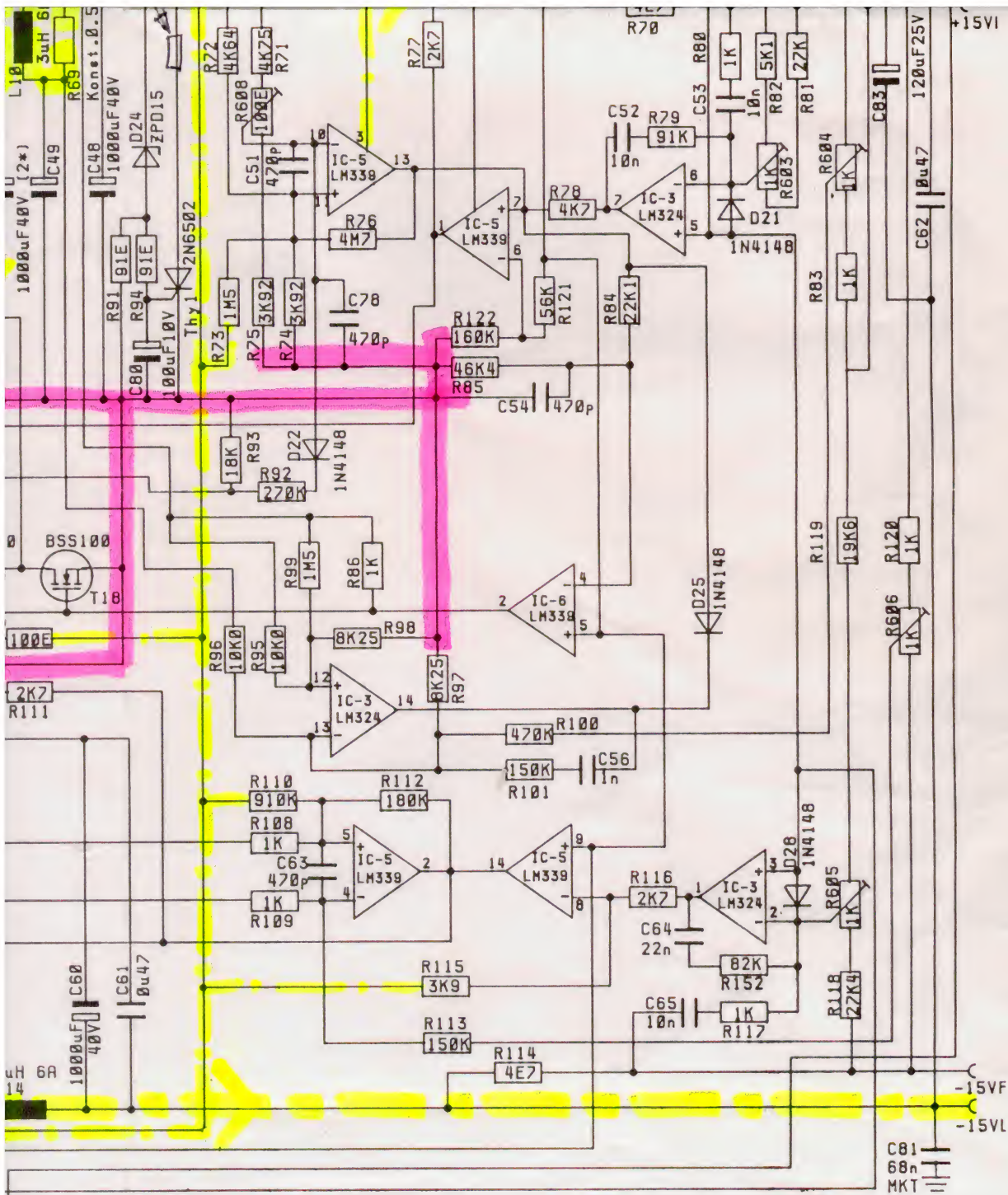

SMG-4031

MASSTAB  
Z.Nr. 551200A

A	D30 UND R150 DAZU	27.03.00	Se.	DATUM	NAME
	R175 Korr.			BEARB. 24.03.00	Jansson
				GEPR.	
				NORM	

+5.2V	8A
+15V	3.5A
-15V	1.5A

BLATT  
81.

ZUST.    ÄNDERUNG    DATUM    NAME    4031 POWER SUPPLY 204 031 S

Proprietary data, company confidential All rights reserved  
 Contido e titre de secret d'entreprise Tous droits réservés  
 Comunicado como segredo empresarial Reservados todos os direitos  
 Acomunicado como secreto industrial. Nos reservamos todos los derechos

Weitergabe sowie Vervielfältigung dieser Unterlage, Verwertung und Mitteilung ihres Inhalts nicht gestattet, soweit nicht ausdrücklich zugestanden. Zuwiderhandlungen verpflichten zu Schadenersatz. Alle Rechte vorbehalten, insbesondere für den Fall der Patenterteilung oder GEM-Eintragung.



1	2	3	4	5
Nr.	Stück	Benennung	Wert	Pos. Sachnummer
1	2	Widerstand 5%	270K R1,2	RH10 55.2700.522.021
2	3		1K R18,27,28	RH10 55.1000.322.021
3	1		680E R20	RH10 55.6800.222.021
4	2		390K R155,154	RH10 55.3900.522.021
5	1		27K R19	RH10 55.2700.422.021
6	2		100E R23,M	RH10 55.1000.222.021
7	1		8K2 R22	RH10 55.8200.322.021
8	1		7K5 R24	RH10 55.7500.322.021
9	1		1M R29	RH10 55.1000.622.021
10	1		1M5 R25	RH10 55.1500.622.021
11	1		10K R3	RH10 55.1000.422.021
12	3		2E2 R9,17,10	RH10 55.2200.022.021
13	1		56K R26	RH10 55.5600.422.021
14	1		2K7 R6	RH10 55.2700.322.021
15	1		1K8 R5	RH10 55.1800.322.021
16	1		75 K R7	RH10 55.7500.422.021
17	1		2M2 R156	RH10 55.2200.622.021
18	2		470E R14,15	RH10 55.4700.222.021
19	1		47E R12	RH10 55.4700.122.021
20	1		4K7 R21	RH10 55.4700.322.021
21	1		4E7 R ,4	RH10 55.4700.022.021
22	3		0E	RH10 55.0000.122.021
23	1		6E8 R4	10,16 55.6800.022.021
24	1		47K R8	10,16 55.4700.422.021
25	1	Karstautenbrücke	Ø 1mm R13	RH10 59.0000.010.002

Ersatztypen am: ..... bestätigt durch: .....

Datum	18.12.87	SMG - 4031 Kleine LP HV-LP Sonderliste	2
Bearb.	Q		
Gepr.			
Norm.			
		ZNr. 551.401 F	Blatt 1

Proprietary data, company confidential. All rights reserved.  
 Confidencial e secreto empresarial. Todos los derechos reservados.  
 Comunique como segredo empresarial. Reservados todos os direitos.  
 Proprietariedade e informacões confidenciais. Todos os direitos reservados.  
 Contado como secreto industrial. Nos reservamos todos los derechos.

Weitergabe sowie Veröffentlichung dieser Unterlagen, Wertung und Mitteilung ihres Inhalts nicht gestattet, soweit nicht ausdrücklich zugestanden. Zuwiderhandlung verpflichtet zu Schadensersatz. Alle Rechte vorbehalten, insbesondere für den Fall der Patenterteilung oder GM-Eintragung.

Nr.	Stück	Benennung	Wert	Pos.	Sachnummer
26	2	Diode	1N4148 D 12,10	RH10	44.000.41.080.010
27	1		BA 159 D, 9	RH10	44.000.1.590.510
28	3		1N4934 E100 SRP100K	RH10	44.000.1.000.790
			D8,2,5		—
30	1		SRP 100K 33	10,16	
31					
32	2	Kondensator	202 C 16,15	RH5	52.1220.909.200
33	2		427 C 14,10	RH5	52.1470.909.200
34				RH5	
35				RH5	
36	3		041 C 8,17,75	RH5	52.1100.708.200
37	1		14F C 18	RH5	52.1100.909.200
38	2		470pF C 19,20	RH5	52.1471.009.200
39	1		0447 C 11	RH5	52.1470.708.211
40					
41					
42	1	Blankdrahtbrücke	Ø 1mm	15,24	38.6100.100.035
43					
44	1	Widerstand 5%	1K R18 stehend		55.1000.322.021
45	1		750K R58		55.7500.522.021

Ersatztypen am: ..... bestätigt durch: .....

Datum	18.12.87	SMR - 4031 Kleine LP, HV-LP sauberste	2
Bearb.	A		
Gepr.			
Norm.			
		ZNr. 551.401 F	Blatt 2

TR	Ausg.	Änderung/Mitteilung	Datum	Name

4031 POWER SUPPLY 204 031 SaBl. 2/18

Nr.	Stück	Benennung	Wert	Pos.	Sachnummer
1	1	Leiterplatte	551.301 C		71.5513.010.471
2	1	Diode	ZPD 8,2 D11	RH10	44.0000.820.810
3	1		ZPD 27 D37	RH10	44.0000.270.810
4	3		ZY 1.00 D1,14,38	RH10	44.0010.000.820
5	1		BC 102/1,4 <sup>Ersatz D35</sup> 32W46/1,5	RH10	44.0000.460.570
6	1		A9903 D4	RH10	44.0099.030.480
7	2		UF 4007 D67	RH10	44.0040.070.740
8	1	skrand	ZPD 2,7 D		44.0000.270.810
9	1	IC	TL 495 IC1		41.0047.180.070
10	1		6N 136 B101		41.0001.360.040
11	1		CNY -21 B100		41.0000.210.130
12					
13	1	Kühlkörper	65 B 330		48.3000.0000.190
14	3	Transistor	BSS 100 T8,7,6		42.9001.000.251
15	1		BC 307 Ersatz BC 557 74		42.0005.470.190
16	1		3C 161-16, 71		42.0001.610.180
17	1		BD 785 T5		42.0007.850.220
18	1	Widerstand 5%	ZFK 2W R16		55.2700.425.700
19					
20	1	704	500K 3386X R600		56.5000.533.541
21	1	Kond	50K R609		56.5000.432.511
22					
23	1	Schalter	CuK 1101 S1		38.7001.002.000
24	1	WDR	S14 K275 R900		57.1142.750.610
25	1	NTC	SG 27 R800		57.1000.270.610

Ersatztypen am: ..... bestätigt durch: .....

Datum: 4.1.88  
 Bearb.: [Signature]  
 Gepr.:  
 Norm.:

SMG - 4031  
 HV - LP  
 Bestellung



ZNr. 551.401 F

2

Blatt 1

Como a una de sus actividades más importantes  
 Comunicado como objeto principal (Reservado todos los derechos)  
 Reservados todos los derechos. No se permite la explotación económica ni la  
 Conflicto como actividad industrial. No se reservan todos los derechos

Every use of this information must be made in good faith, and  
 not exclusively for the purpose of making copies or reproductions  
 without the express written permission of the copyright owner. All  
 rights reserved. No part of this publication may be reproduced, stored in a  
 retrieval system, or transmitted in any form or by any means, electronic, mechanical, photocopying, recording, or by any information storage and retrieval system, without the prior written permission of the copyright owner.

Proprietarilor și utilizatorilor de echipamente electrice și electronice  
 Conținutul este de strictă confidențialitate. Toate drepturile sunt rezervate.  
 Comunicado como segredo empresarial. Reservados todos los derechos.  
 Apropriata este marca comercială. Este un produs comercializat în numele  
 Confidat como secreto industrial. Nos reservamos todos los derechos

Vertriebs- sowie Vertriebs- und Vertriebs-Unterlagen, Ver-  
 wendung und Mitteilung ihres Inhalts nicht gestattet, soweit  
 nicht ausdrücklich zugelassen. Zuwiderhandlungen ver-  
 pflichten zu Schadensersatz. Alle Rechte vorbehalten, insbe-  
 sondere für den Fall der Patenterteilung oder GM-Eintragung



Nr.	Stück	Benennung	Wert	Pos	Sachnummer
26	1	bleidiodeter	B500 C 1400 D500		44.0100.001.181
27	1	Si-Halter u. Keye	FAB00313551 F100		38.7004.003.000
28	1	Si-Drosslung	AT 1,6 bei 220V FA		38.7040.100.040
29					
30					
31	2	Kondensator	Qm33 250V FA72 C1		52.1330.712.200
32	2	Kondensator	RY 2n5 C34		52.1250.912.401
33	1		RY 1n C12		52.1100.912.400
34	1	Elko sterend	470µF25V SXE C9		53.1470.404.611
35	1		10µF35V C13		53.1100.505.600
36	2		220µF250V KHE C5,6		53.1220.412.612
37	1		100µF350V KHE C7		53.1100.413.600
38					
39					
40	1	Spule	532.104 Ø L1		66.2532.104.010
41	1		6,8µH 0,8A L3		66.1680.508.000
42	1		120µH 3V2060 L2		66.1120.710.000
43	1	Schraubflansch	Ø12,1mm 35mm		38.6312.158.035
44	1	Kabelbinder	SSI 1,5		38.6000.002.000
45	1	Empressmutter	M3		38.2130.000.060
46					
47	1	Kaltgefiedose	4300.0071 x1		38.8003.005.000
48	1	Schraube	M3X10 DIN 7985		38.2130.010.100
49	1		M3X8 DIN 7985		38.2130.008.100
50	2	Federscheibe	A3 DIN 137		38.2230.000.270
51	1	Mutter	M3 DIN 934		38.2130.000.010

Ersatztypen am: ..... bestätigt durch: .....

Datum	4.1.88	SMA - 4031 HU - LP Bestückung	2
Bearb.			
Gepr.			
Norm.			
		ZNr. 551.401 F	Blatt 2







Proprietary data, company confidential. All rights reserved.  
 Contido a titre de secret d'entreprise. Tous droits réservés.  
 Comunicado como segredo empresarial Reservados todos os direitos.  
 Dispozycja na nieoznaczone miejsce. Nie rozpowszechniać za wyjątkiem  
 Confidado como secreto industrial. Nos reservamos todos los derechos.

Weitergabe sowie Vervielfältigung dieser Unterlagen, Verwertung und Mitteilung ihres Inhaltes nicht gestattet, soweit nicht ausdrücklich zugestanden. Zuwiderhandlungen verpflichten zu Schadensersatz. Alle Rechte vorbehalten, insbesondere für den Fall der Patenterteilung oder G.M.-Eintragung.

Nr.	Stück	Benennung	Wert	Pos.	Sachnummer
1	13	Widerstand 50%	1K R 67,43,35,86,108,	RH10	55. 10000. 322.021
2			109,48,49,80,83,117,120		—
3			58,		—
4	6		4K7 R 150,78,55,56,57,90	RH10	55.4700. 322.021
5	3		180E R 60,104,42,	RH10	55. 18000. 222.021
6	4		2E 2 R 64,65,103,41,	RH10	55. 22000. 022.021
7	2		39E R 62,38,	RH10	55. 39000. 122.021
8	6		4E7 R 88,61,70,114,60	RH10	55. 47000. 022.021
9	7		91E R 63,102,39,46,47,94,	RH10	55. 91000. 122.021
10	1		270E R 105,	RH10	55. 27000. 222.021
11	2		100E R 106,87,	RH10	55. 10000. 222.021
12	3		8K2 R 146, 127,115,	RH10	55. 82000. 322.021
13	3		18K R 144,93,129,	RH10	55. 18000. 422.021
14	5		27K R 147,142,138,81,148	RH10	55. 27000. 422.021
15	1		24K R 149,	RH10	55. 24000. 422.021
16					
17	2		10K R 37,139,	RH10	55. 10000. 422.021
18	2		33K R 143,133,	RH10	55. 33000. 422.021
19	5		2K7 R 52,77,111,116,	RH10	55. 27000. 322.021
20			59,		—
21	1		68E R 30,	RH10	55. 68000. 22.071
22	1		330E R 33,	RH10	55. 33000. 222.021
23	1		75K R 141,	RH10	55. 75000. 422.021
24	2		15K R 153,134,	RH10	55. 15000. 422.021
25	3		270K R 92,137,136	RH10	55. 27000. 522.021

Ersatztypen am: .....

bestätigt durch: .....

Datum	18.12.87	SMA-4031 Stück LP Sonderliste	4
Bearb.	<i>[Signature]</i>		
Gepr.			
Norm.			
<b>MGV</b>		ZNr. 551.400 E	Blatt 1



Proprietary data, company confidential. All rights reserved.  
 Confie à titre de secret d'entreprise tous droits réservés  
 Comunicado como secreto empresarial. Reservados todos los derechos  
 Доверенна на информацията. Не разкривайте. Сохраняйте в тайне.  
 Confiado como secreto industrial. Nos reservamos todos los derechos.

Weitergabe sowie Vervielfältigung dieser Unterlage, Verwertung und Mitteilung ihres Inhalts nicht gestattet, soweit nicht ausdrücklich zugestanden. Zuwiderhandlungen verpflichten zu Schadenersatz. Alle Rechte vorbehalten, insbesondere für den Fall der Patenterteilung oder GM-Eintragung.



Nr.	Stück	Benennung	Wert	Pos.	Sachnummer
26	2	Widerstand 5% 470K	R 110, 100	RH10	55. 4700. 522. 021
27	1	180K	R 12,	RH10	55. 1800. 522. 021
28	1	910K	R 110,	RH10	55. 9100. 522. 021
29	2	150K	R 113, 101, 54	RH10	55. 1500. 522. 021
30	1	4M7	R 76,	RH10	55. 4700. 622. 021
31	2	1M5	R 73, 94	RH10	55. 1500. 622. 021
32	1	160K	R 122,	RH10	55. 1600. 522. 021
33	1	56K	R 121,	RH10	55. 5600. 422. 021
34	1	91K	R 79,	RH10	55. 9100. 422. 021
35	2	6K8	R 131, 130	RH10	55. 6800. 322. 021
36	1	680K	R 50,	RH10	55. 6800. 522. 021
37	2	82K	R 152, 53	RH10	55. 8200. 422. 021
38	1	680E	R 135,	RH10	55. 6800. 222. 021
39	1	330K	R 132,	RH10	55. 3300. 522. 021
40	1	36K	R 123,	RH10	55. 3600. 422. 021
41	3	47K	R 125, 124, 106,	RH10	55. 4700. 422. 021
42	1	5K1	R 82,	RH10	55. 5100. 322. 021
43	2	220K	R 51, 34	RH10	55. 2200. 522. 021
44	1	510E	R 36	RH10	55. 5100. 222. 021
45					
46					
47					
48					
49					
50					

Ersatztypen am: ..... bestätigt durch: .....

Datum 18.12.87  
 Bearb. [Signature]  
 Gepr.  
 Norm.

SMR - 4031  
 Stecker L.P.  
 Sauerliste

4



ZNr. 551.400

Blatt

2

TR Ausg. Änderung/Mitteilung Datum Name 4031 POWER SUPPLY 204 031 SaB1.8/18

Proprietary data, company confidential. All rights reserved.  
 Conținut în titlu de secret d'antrepris. Tous droits réservés.  
 Comunicado como segredo empresarial Reservados todos os direitos.  
 Desapareca sau nu se poate copia. Не разглашайте и не копируйте.  
 Confidado como secreto industrial. Nos reservamos todos los derechos.

Weitergabe sowie Vervielfältigung dieser Unterlage, Verwertung und Mitteilung ihres Inhalts nicht gestattet, soweit nicht ausdrücklich zugestanden. Zuwiderhandlungen verpflichten zu Schadenersatz. Alle Rechte vorbehalten, insbesondere für den Fall der Patenterteilung oder GMI-Eintragung.

1	2	3	4	5
Nr.	Stück	Benennung	Wert	Pos. Sachnummer
51	1	Widerstand 1%	4K75 R 71	RH10 55.4750.313.021
52	1		6K81 R 32	RH10 55.6810.313.021
53	1		4K64 R72,	RH10 55.4640.313.021
54	2		3K92 R74,75,	RH10 55.3920.313.021
55	1		46K4 285,	RH10 55.4640.413.021
56	1		22K1 R84,	RH10 55.2210.413.021
57	2		10K0 R95,96	RH10 55.1000.413.021
58	2		8K25 R97,98	RH10 55.8250.313.021
59	1		19K6 R119,	RH10 55.1960.413.021
60	1		27K4 R118,31	RH10 55.2740.413.021
61				
62	1		0E	RH10 55.0009.127.021
63				
64				
65	7	Diode	1N4148 D32,33,22,30	RH10 44.0041.480.010
66			25,28,21	—
67	1		1N4934 Eisole SRP100K D38	RH10 44.0001.000.790
68				
69				
70	9	Kondensator	0,47 C77,45,46,32,33,	RH5 52.1470.708.211
71			38,50,62,61,	—
72	6		10nF C30,52,53,65,72,40	RH5 52.1100.809.200
73	3		4n7 C58,79,43,	RH5 52.1470.909.200
74				
75	6		470pF C78,51,54,69,53,41	RH5 52.1471.009.200

Ersatztypen am: .....

bestätigt durch: .....

Datum: 18.12.87  
 Bearb: (A)  
 Gepr:  
 Norm:

SMQ - 4031

Stecker LP Saubeliste

4



2 Nr. 551.400 E

Blatt 3

TR	Ausg	Anderung/Mitteilung	Datum	Name

4031 POWER SUPPLY 204 031 SaBI. 9/18



Confidantia: este documento contém informações sigilosas reservadas para uso interno da GM. Não divulgar para terceiros. Reservados todos os direitos.

Transmissão ou divulgação, mesmo que parcial, sem a autorização da GM constitui infração das leis de direitos autorais e pode acarretar sanções legais. Reservados todos os direitos.

Nr.	Stück	Benennung	Wert	Pos.	Sachnummer
1	1	Leiterplatte	551.300 C		71.5513.000.421
2	1	Diode	ZPD 27 D34	2410	44.0000.270.810
3	2		BZ102/1,4 Ersatz BZW 46/1,5 DAB,15	2410	44.0000.460.570
4	1		AN823 IC8	2410	44.0008.230.040
5	1		ZPD 5,1 D17	2410	44.0000.510.810
6	1		ZPD 15 D24	2410	44.0001.500.810
7	1		ZPD 6,8 D31	2410	44.0000.680.810
8	1		ZPD 13 D23	2410	44.0001.300.810
9	1		ZPD 9,1 D29	2410	44.0000.910.810
10	1		SB 140 D26	2410	44.0001.400.730
M					
12	2	IC	LM324 IC4,3		41.0003.240.070
13	3		LM339 IC6,5,2		41.0003.390.060
14	2		TL 431 IC9,7		41.0004.310.150
15	1	Widerstand 5%	10E 1W NK4 R151		55.1000.134.400
16	1		1K 1W NK4 R128		55.1000.324.400
17					
18	3	Spule	6,8µH 0,7A L8,6,12		66.1680.508.000
19	3		3µH 6A L11,10,14		66.1030.660.000
20					
21	1	Transistor	BSS 110 TA		42.9001.100.250
22	2	Transistor	BSS 100 TAB, 126		42.9001.000.251
23	4		BC237 Ersatz BC547		42.0005.470.190
24			T 16,23,12,25		—
25	3		Ersatz ZTX 552 ZTX 551 T15,11,22		42.0005.520.470

Ersatztypen am: ..... bestätigt durch: .....

Datum	4.1.88	SMG - 4031 Stecker - LP Bestückung	3
Bearb.	EL		
Gepr.			
Norm.			
		ZNr. 551.400 E	Blatt 1

Contida a titre de social d'inventaire Tous droits réservés  
 Comunicado como seguro empresarial Reservados todos los derechos.  
 Розписка на підприємстві не є гарантією. Не передавати права.  
 Confirmando como seguro industrial. Nos reservamos todos los derechos

Die Erfindung ist durch die Anmeldung geschützt. Die Erfindung ist durch die Anmeldung geschützt.  
 The invention is protected by the application. The invention is protected by the application.  
 Die Erfindung ist durch die Anmeldung geschützt. Die Erfindung ist durch die Anmeldung geschützt.  
 The invention is protected by the application. The invention is protected by the application.

Nr.	Stück	Benennung	Wert	Pos.	Sachnummer
26	2	Transistor	3D 788 T13,9		42.000.7880.220
27	2		RSX46 T20,24		42.000.460.261
28	2	AWS	MO 455		48.400.1.000.020
29	2	Kühlkern	FE38A		48.300.1.000.010
30					
31					
32	6	Resistor	1K 3386X R604,603,		56.100.333.541
33			605,601,606,602,		—
34	1	Mund	100E R608		56.100.232.510
35	1	Mund	5K R607		56.500.332.510
36					
37					
38	5	Kondensator	68nF MKTAP22 C39,		52.1680.812.211
39			40,81,28,29,		—
40					
41					
42	1	Elektrolyt	470µF 25V C74,		53.1470.404.600
43	3		10µF 16V C55,44,68,		53.1100.502.600
44	1		100µF 40V C27 KHC		53.1100.406.611
45	1		10µF 63V C67		53.1100.508.611
46	2		100µF 10V C30,34		53.1100.401.611
47	1		100µF 25V C76		53.1100.404.611
48	11		1000µF 40V EKR		53.1100.306.600
49			C23,26,57,22,24,25,47,59,		—
50			48,60,49,		—

Ersatztypen am: ..... bestätigt durch: .....

Datum	4.1.88	SMG-4031 Stecker-LP Bestückung	3
Bearb.	Q		
Gepr.			
Norm.			
<b>MGV</b>		ZNI. 551.400 E	Blatt 2

Proprietariness "data" "category" "Commercial" "All Rights Reserved."  
 Contis à titre de secret d'entreprise Tous droits réservés  
 Comunicado como segredo empresarial Reservados todos los derechos  
 Aparece caa propriedade empresarial. Bie opaz, copanenuka za nam  
 Confidado como secreto industrial. Nos rezervamos todos los derechos

Verwendbarkeit "Büro" "Veröffentlichung" "Dieses" "Unterlage", ver-  
 weisung der Mitteilung ihres Inhalts nicht gestattet, soweit  
 nicht ausdrücklich zugestanden. Zuwiderhandlungen ver-  
 pflichten zu Schadensersatz. Alle Rechte vorbehalten, insbe-  
 sondere für den Fall der Patenterteilung oder GfK-Entragung.



Nr.	Stück	Benennung	Wert	Pos.	Sachnummer
51	3	Elbro Stehend	2200µF 16V EKR		53.1220.302.600
52			C35,36,37		—
53					
54					
55	1	Si-Halter	19782 F101		38.7004.012.000
56	1	Sicherung	H120 F2		38.7042.000.040
57	1	St-Kappe	19785 F102		38.7004.013.000
58	1	Stecker	2,5 MSF 03 X 2		38.8003.025.000
59	2	Steckzunge	6,3 X3,4		38.8003.023.000
60					

Ersatztypen am: ..... bestätigt durch: .....

Datum	4.1.88
Bearb.	B
Gepr.	
Norm.	

SMR - 4031  
Stecker LP  
Zerstückung

3



2Nr. 551.400 E

Blatt  
3

Copyright reserved. All rights reserved.  
 Contida a titre de secret d'entreprise tous droits réservés.  
 Comunicado como segredo empresarial. Reservados todos os direitos.  
 Reservados todos los derechos. No se permite su reproducción sin el consentimiento escrito de la empresa.  
 Confidado como secreto industrial. No se reservan todos los derechos.

Die vorliegende Zeichnung ist eine Erfindung, deren Offenlegung, Verbreitung und Mitteilung ihres Inhalts nicht gestattet, soweit nicht ausdrücklich zugestanden. Zuwiderhandlungen verpflichten zu Schadenersatz. Alle Rechte vorbehalten, insbesondere für den Fall der Patenterteilung oder GM-Eintragung.

Nr.	Stück	Benennung	Wert	Pos.	Sachnummer
1	1	Kühlwuhel	551.003 C		34.4551.003.031
2	2	Abstandsbohren	M2,5x5 AH 2505		38.3010.100.500
3	1	Transistor	BUZ 11A T17		42.0000.110.300
4	1		D44 VH10 T21		42.0000.440.490
5	2		BUW 50 T14,10		42.0000.500.200
6	4	Diode	SB1045 D20,19,27 <sup>10</sup>		44.0010.450.750
7	1		SD 241 P D14		44.0002.410.780
8	1		FEP303P D13		44.0000.300.670
9	2	Thyristor	2N6502 Thy 12		43.0065.020.020
10	1	Halterung	551.006 C		35.8551.006.031
11	2		420.003 Ø		35.8420.003.011
12	1		420.002 C		35.8420.002.041
13	1	NTC	150K K45 R801		57.1150.050.601
14	1	Schnurverschraubung	Ø1,6mm 100mm		38.6311.016.100
15	2	Schraube	M2,5x20 DIN 84		38.2125.025.130
16					
17	1	Isolierung	551.013 Ø		36.7551.013.011
18	1		551.014 Ø		36.7551.014.011
19					
20	1	Schraube	M2,5x10 DIN 84		38.2125.010.130
21	3	Federung	M2,5 DIN 127A		38.2225.000.260
22	1	Schraube	M3x8 DIN 7985		38.2130.008.100
23	1	Belagbohrbohrer	14,2 DIN 125B		38.2230.000.750
24	1	Isolierwulst	KU 6 - 650		48.2303.423.102
25	1	Sil-Pad	7429 - 10 - 54		48.3220.100.000

Ersatztypen am: ..... bestätigt durch: .....

Datum	4.1.88	SMG 4031	1
Bearb.	Q		
Gepr.			
Norm.			
		Kühlwuhel	
		ZNr 551.400 E	Blatt 1











Copyright reserved. All rights reserved.  
 Contido libre de secret. d'entrepreneur. Tous droits réservés.  
 Comunicado como registro empresarial. Reservados todos los derechos.  
 Reservados todos os direitos. Reservados todos os direitos.  
 Conținutul este proprietate intelectuală. Nu s'au rezervat toate drepturile.

Verbreitung und Mitteilung dieses Zeichens nicht gestattet, soweit nicht ausdrücklich abgemacht. Wiederholungen, Ver-  
 pflichtung zu Schutzmaßnahmen. Alle Rechte vorbehalten, insbe-  
 sondere für den Fall der Patenterteilung oder GEM-Eintragung.



1	2	3	4	5
Nr.	Stück	Benennung	Wert	Pos. Sachnummer
1	1	U-Wand	551.001 A	33.5551.001.021
2	1	Drassio	551.002 & D	33.5551.002.051
3	1	Haltezung	551.008 Ø	35.8551.008.011
4	1	Isolierung	551.009 A	36.7551.009.021
5	1	Schraube	M3x6 DIN 965	38.2130.006.110
6	1	Lotholue	M3 Kupfer	38.4070.032.174
7	1	Mutter	M3 DIN 934	38.2130.000.010
8				
9	8	Schraube	M3x6 DIN 966	38.2130.006.124
10	1	Abdeckkappe	551.010 Ø	33.3551.010.011
11	1	Mutter	M6 M5 DIN 934	38.2160.000.010
12	18	Schraube	M 2,5x 5 DIN 965	38.2125.005.110
13				
14				
15	1	Federling	A6 DIN 127	38.2260.000.260

Ersatztypen am: ..... bestätigt durch: .....

Datum	5.1.88	SMG - 4031 Endmontage	1
Bearb.	[Signature]		
Gepr.			
Norm.			
<b>MGV</b>		2Nr. 551.400 E	Blatt 1

On the circuit board of modulation generator A there is AF generator A, the summing and output amplifier for the TX mode, the summing amplifier for the RX mode, the AM RF level control, the preemphasis network and the deviation compensation stage. The signals of generator A, generator B and an external signal can be superimposed on the summing amplifiers.

### 1. Modulation generator A (sinewave generator)

Modulation generator A consists of a digital synthesizer (gate array) in which the signal is first conditioned digitally and with crystal-based accuracy. An arithmetic unit determines the binary sample values for the sinewave time function that is to be generated.

A sinusoidal oscillation is then produced from the binary sample values by a digital/analog converter. A subsequent, switchable lowpass filter smooths the signal so that a frequency-stable oscillation of high signal quality is produced which can be set in discrete increments.

Gate array GA1 on the circuit board includes a phase accumulator, latches ( $\mu$ P-compatible 8-bit bus) and a switchable frequency divider for the system clock.

#### 1.1 Phase accumulator

The numeric value of the frequency setting is fed to the phase accumulator as the increment  $\delta$ . The output is incremented by the value  $\delta$  with each clock pulse from the divided oscillator frequency. When the range of values of the accumulator is exhausted, the output jumps back to  $0 \dots \delta$  and the process commences again. In this way a numeric sequence is produced with a sawtooth-shaped characteristic. The slope of the sawtooth and thus its frequency is given by the increment  $\delta$  from the  $\mu$ P and by the switchable frequency divider, which divides the frequency of the step sequence by 4 or 40.

Ref.No. 208 029 F	Sub Modulation Generator A	Date
Type 4031	Unit	Sheet 1/6
<b>Schlumberger</b>		Functional Description

### 1.2 D/A conversion (sine table, D/A converter)

The digital sawtooth generated in the phase accumulator is converted into a digital sinewave equivalent by EPROM P1. This includes a sine table for the range 0 to 360° with 8-bit amplitude resolution. The data are applied to a digital/analog converter on whose output a finely graded, staircase-shaped sinewave voltage of the required voltage and of constant amplitude appears (approx. 10 V<sub>pp</sub>).

### 1.3 Electronic attenuator (level control)

The voltage on the interface between the generator and attenuator is approx. 10 V<sub>pp</sub>. This attenuator consists of a fine divider 0-1000 and a rough divider  $\times 1/\times 0.2/\times 0.02/\times 0.002$ . The fine divider is configured as a multiplying binary 10-bit DAC in which only 1000 increments are weighted in order to produce an integral division of 0-1000. The following rough divider works in decades and in this way high resolution is achieved at small voltages.

### 1.4 Lowpass filter

A lowpass filter follows that can be switch-selected in its cutoff frequency to reject interference through amplitude and phase instability.

### 1.5 Frequency ranges

The generator has two frequency ranges:

30.0 Hz to 2.999 kHz  
3.00 kHz to 29.99 kHz

These are produced by the switch-selected division of the crystal clock frequency. Fine division of the frequency in the ranges is by different increments:

$$f = 4 \times \frac{\text{Increment}}{\text{Division factor}}$$

Range	Division factor	Increment
30.0 Hz to 2.999 kHz	40	Set frequency x 10
3 kHz to 29.99 kHz	4	Set frequency x 1

Ref.No. 208 029 F  
Type 4031

Sub Modulation Generator A  
Unit

Date  
Sheet 2/6

The clock oscillator can be switched off by a control line to keep interference in the unit as low as possible.

Examples:

a)  $f = 512 \text{ Hz}$

1. The frequency is in the range 30.0 Hz through 2.999 kHz.  
The oscillator frequency of 2.097152 MHz is divided by 40  
-->  $52.429 \text{ kHz} = 2^{19} \text{ Hz}/10$ .
2. The increment is  $5120 = 2^9 \times 10$ .
3. Because the phase accumulator has a length of  $2^{19}$  bits, it is full after

$$\frac{2^{19}}{2^9 \times 10} = \frac{2^{10}}{10} = 102.4 \text{ increments.}$$

The sawtooth frequency and thus the output frequency are

$$\frac{52.429 \text{ kHz}}{102.4} = 512 \text{ Hz.}$$

b)  $f = 4096 \text{ Hz}$

1. The frequency is in the range 3 kHz to 29.99 kHz.  
Division factor: 4 -->  $f_{\text{clock}} = 524.288 \text{ kHz}$
2. The increment is 4096.

$$3. f_{\text{out}} = 4 \times \frac{\text{Increment}}{\text{Division factor}} = 4 \times \frac{4096}{4} = 4096 \text{ Hz}$$

Ref.No. 208 029 F	Sub Modulation Generator A	Date
Type 4031	Unit	Sheet 3/6
Schlumberger		Functional Description

## **2. Output amplifiers**

There are separate output amplifiers for the RX and TX modes.

### **2.1 TX mode: TX amplifier**

The voltages of the two modulation generators A and B and an external modulation voltage can be added by op-amp A12. In this way dual modulation is possible. Transistors T11 and T12 serve as a booster for high output currents, T10 and T13 limit the output current to admissible values in the event of a shortcircuit. An output transformer on the motherboard (361 136) between the amplifier and output socket balances the output voltage. The transformer can be switched between 1:1 and 1:10. The output voltage is max.  $5 V_{rms}$  into max.  $200 \Omega$ .

### **2.2 TX DC amplifier**

The TX DC amplifier (A11) supplies the same output signal DC-coupled to the DC OUT socket (Bu29) as the TX amplifier to the MOD GEN socket on the front panel. If the output transformer is switched to 1:10, the TX DC amplifier is also switched to 1:10.

### **2.3 RX mode: RX amplifier**

The voltages of the two modulation generators A and B and an external modulation voltage can be added by op-amp A10. In this way dual modulation is possible. The summed signal appears on the RX MOD socket (Bu27) on the circuit-board backplane. Modulation is defined as a peak value, so the amplifier produces max.  $2 V_p$  for 100% AM and  $2 V_p$  for 40-kHz FM deviation into  $600 \Omega$ .

Ref.No. 208 029 F	Sub Modulation Generator A	Date
Type 4031	Unit	Sheet 4/6
Schlumberger		Functional Description

#### 2.4 AM modulation

The RX voltage, added to a DC voltage (5-V reference), produces the signal for amplitude modulation. The electronic AM attenuator also sets the RF level when there is no modulation.

#### 2.5 FM modulation

The compensation of FM deviation is necessary at different carrier frequencies. Finely graded division of the RX FM signal is produced with a multiplying D/A converter.

#### 2.6 ΦM modulation

The preemphasis network makes it possible to generate phase modulation by means of the FM modulator.

Ref.No. 208 029 F	Sub Modulation Generator A	Date
Type 4031		Sheet 5/6
Schlumberger	Functional Description	



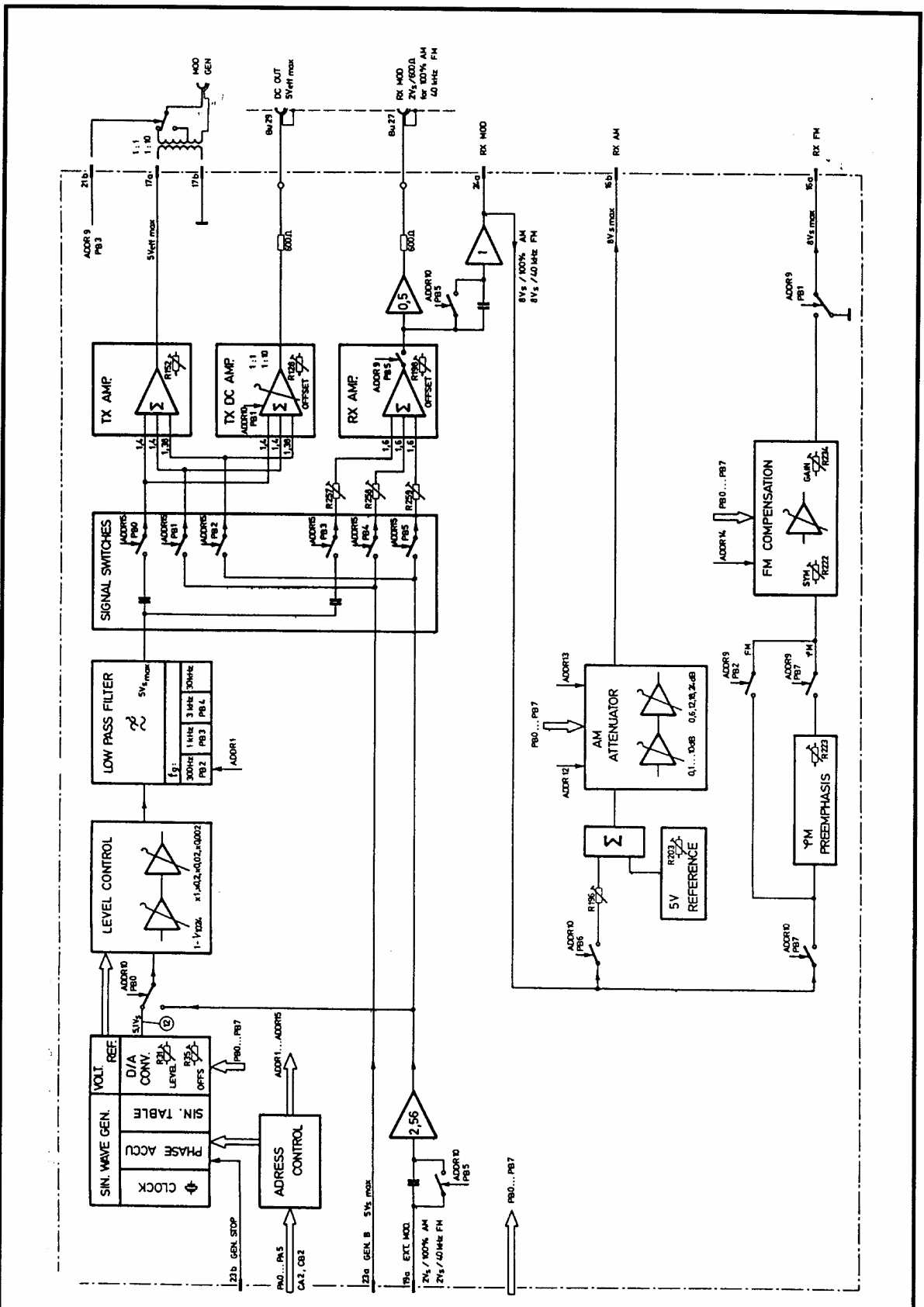

Ref. No. 208 029 F  
 Type 4031

Sub Modulation Generator A  
 Unit

Date  
 Sheet 6/6

Schlumberger

Functional Description

Schlumberger		Adjustment and Test Procedure										Sheet	
Necessary Equipment	Measuring Procedure	Measuring Point	Frequency	Adjustment	Set Value	Actual Value	Issue	Alteration No.	Date	Name	Ref. No.	Sub Unit	Modulation Generator A
							Alteration No.	Date	Name	No.	Type		
Oscilloscope, HP audio analyzer, DVM 7150 or better	Check oscillator and frequency divider 4031 setting: Mod. frequ. 16.384 kHz/5 V <sub>rms</sub>	10			2.097152 MHz ± 84 Hz								
		11 30			524.288 kHz ± 21 Hz 52.429 kHz								
Frequency counter	Jumper set 1-2 Mod. frequ. 1 kHz												
Oscilloscope	D/A converter 4031 setting: Mod. frequ. 16.384 kHz/5 V <sub>rms</sub> Check quantized sinewave for voltage spikes and dips	12											
DVM	Offset adjustment 4031 setting: Mod. frequ. 16.384 kHz/5 V Jumper set 2-3	12	DC	R35	0 mV ± 1 mV								

Schlumberger		Adjustment and Test Procedure							Sheet	
Necessary Equipment	Measuring Procedure	Measuring Point	Frequency	Adjustment	Set Value	Actual Value	Ref. No. 208 029 A			
							Issue	Date	Name	Type
DVM	<u>Amplitude adjustment Generator A</u> 4031 setting: Jumper set 1-2 Mod. frequ. 1 kHz/5 V Mod. frequ. 1 kHz/0.1 V  <u>Check of amplitude setting</u> 4031 setting: Mod. frequ. 1 kHz/1 V Mod. frequ. 1 kHz/0.5 V Mod. frequ. 1 kHz/100 mV Mod. frequ. 1 kHz/10 mV  <u>Offset adjustment</u> 4031 setting: Mod. frequ. 1 kHz/10 mV Mod. generator A off  <u>RX mod. adjustment</u> 4031 setting: RX Mod. frequ. 1 kHz/40 kHz dev.	Bu29 Bu29  Bu29 Bu29 Bu29 Bu29  Bu29  St64/24a	1 kHz 1 kHz  1 kHz 1 kHz 1 kHz 1 kHz  DC  1 kHz	R31          R128   R257	5 V ±5 mV 0.1 V ±1 mV  1 V ±10 mV 0.5 V ±5 mV 100 mV ±1 mV 10 mV ±0.2 mV  0 mV ±1 mV  5.657 V ±12 mV				Sub Unit Modulation Generator A	2/8
							Issue	Date	Name	Type
							Alteration No.			STABILOCK 4031

Necessary Equipment	Measuring Procedure	Measuring Point	Frequency	Adjustment	Set Value	Actual Value	Sheet		
							Sub Unit	Modulation Generator A	
Audio analyzer	<p>Check of RX mod. Mod. frequ. 1 kHz/40 kHz dev.</p> <p><u>TX amplitude adjustment</u> 4031 setting: TX Mod. frequ. 1 kHz/5 V</p> <p><u>Ext. mod. TX adjustment</u> 4031 setting: TX, EXT on. Apply to EXT MOD socket: 1 kHz/2 V<sub>p</sub> (1.41 V<sub>rms</sub>)</p> <p><u>Check of TX DC amp., TX amp</u> 4031 setting: 2 kHz/1 V generator A on generator A off</p> <p>2 kHz/0.1 V generator A on generator A off</p>	Bu27	1 kHz		2.828 V ±14 mV		208 029 A	3/8	
		St64/17a	1 kHz	R152	5 V ±15 mV				
		Bu29	1 kHz		5 V ±170 mV			Type STABILOCK 4031	
		St64/17a	1 kHz		5 V ±170 mV				
		Bu29	1 kHz		0.5 V ±17 mV				
		St64/17a	1 kHz		0.5 V ±17 mV				





Necessary Equipment	Measuring Procedure	Measuring Point	Frequency	Adjustment	Set Value	Actual Value	Ref. No. 208 029 A			Sheet
							Issue	Alteration No.	Date	
DVM	<u>AM RF attenuator adjustment</u> 4031 setting: RX Mod. frequ. 1 kHz/1 kHz FM, RF level +5 dBm (RF DIRECT)  4031 setting: RF level -1 dBm (RF DIRECT) Mod. frequ. 1 kHz/0% AM Measure $V_{test}$ (-3.9 V) Mod. frequ. 1 kHz/50% AM  <b>St64/16b must be connected to RF output stage or loaded with 10 <math>\Omega</math>.</b>  <u>FM compensation adjustment</u> 4031 setting: Mod. frequ. 1 kHz/40 kHz dev., RF frequency 500 MHz	St64/16b	DC	R203	-7.852 V $\pm$ 20 mV					
		St64/16b	DC	R156	$V_{test}$ 0.3536 $V_{test}$ $\pm$ 5 mV					
		St64/16a	1 kHz	R234	5.656 V $\pm$ 15 mV					
							Type STABLOCK 4031			6/8







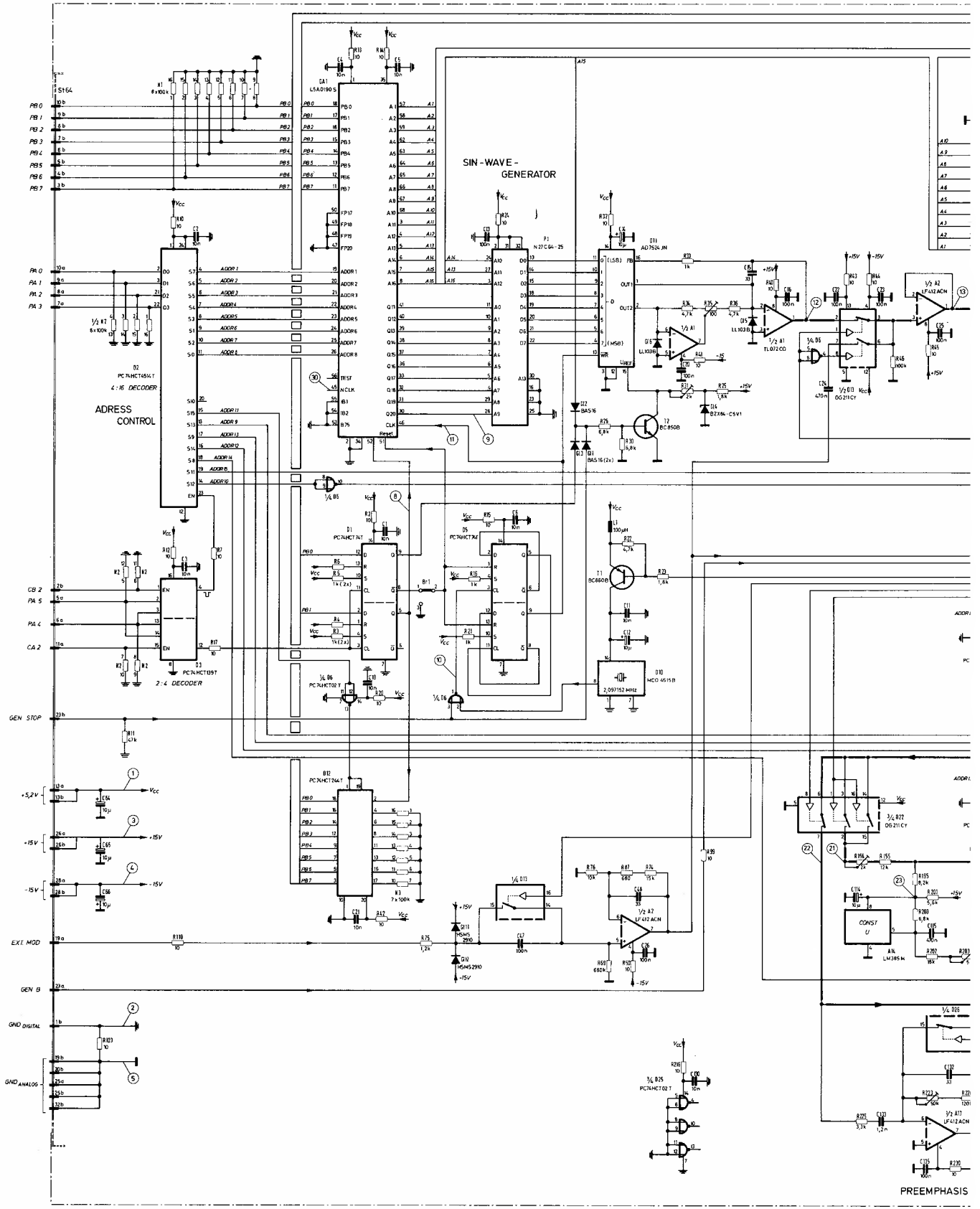

A0
A1
A2
A3
A4
A5
A6
A7
A8
A9
A10
A11
A12
A13
A14
A15

PREEMPHASIS

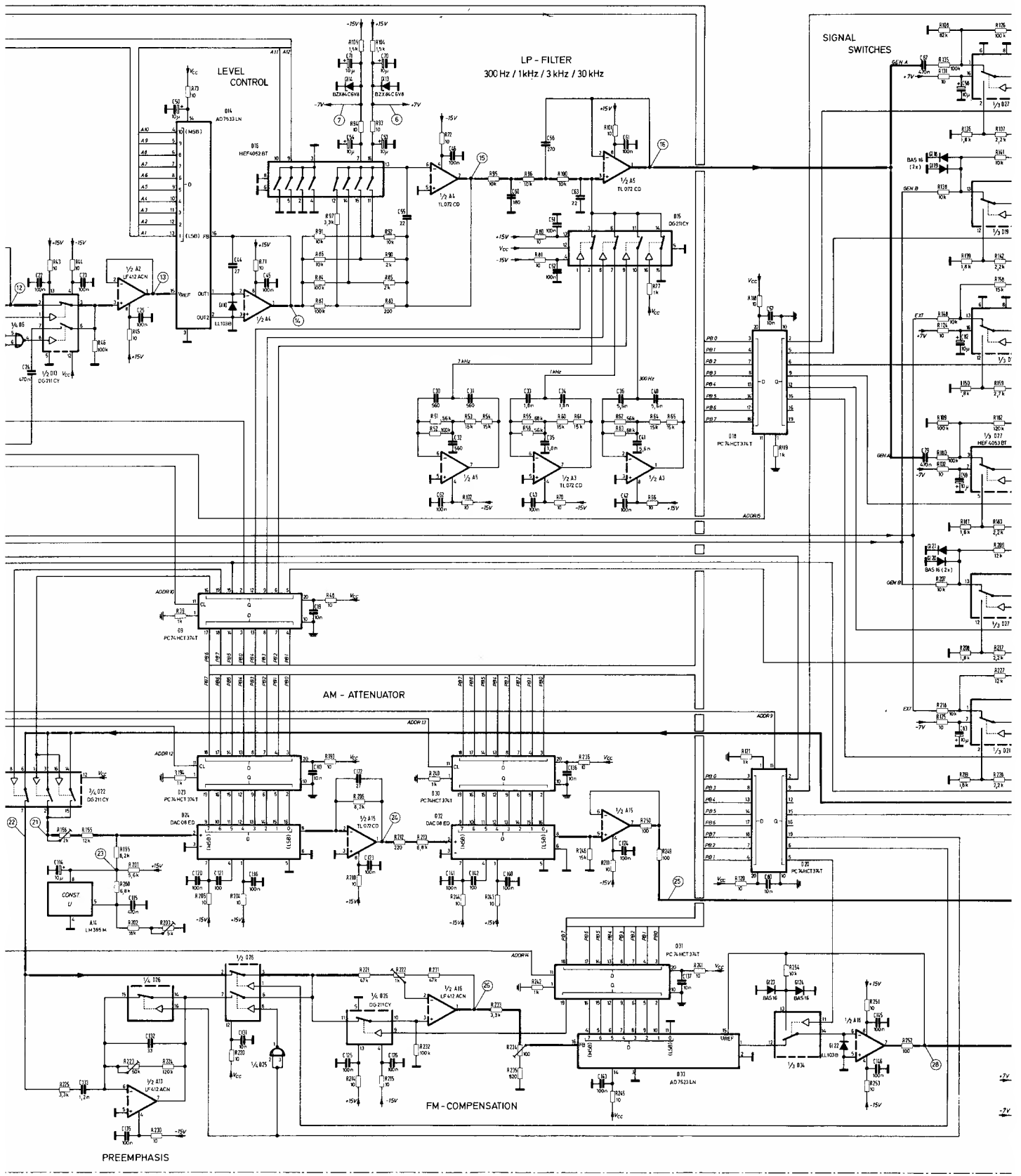

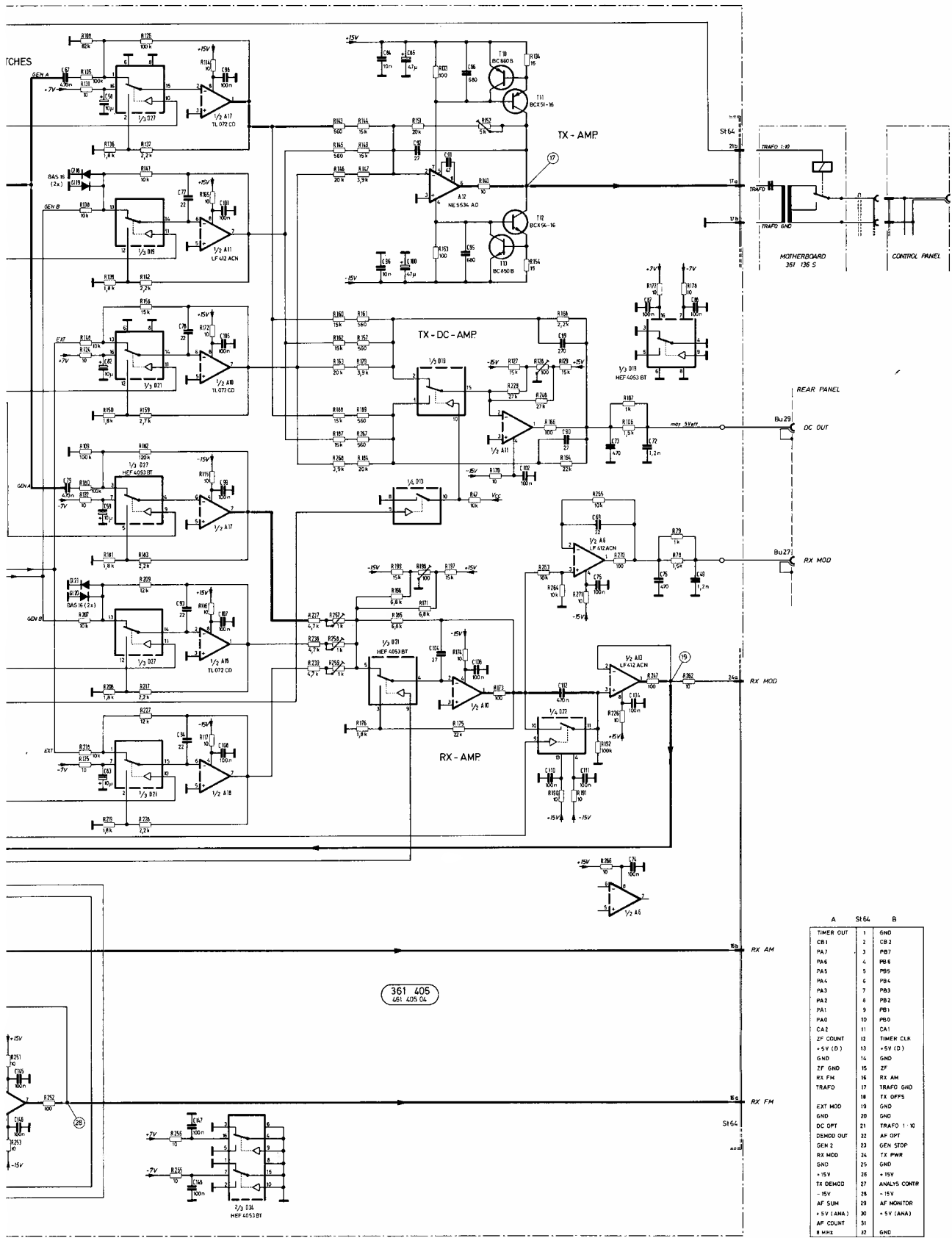

A	SI 64	B
TIMER OUT	1	GND
CB1	2	CB 2
PA7	3	PB7
PA6	4	PB6
PA5	5	PB5
PA4	6	PB4
PA3	7	PB3
PA2	8	PB2
PA1	9	PB1
PA0	10	PB0
CA2	11	CA1
ZF COUNT	12	TIMER CLK
+5V (D)	13	+5V (D)
GND	14	GND
ZF GND	15	ZF
RX FM	16	RX AM
TRAFD GND	17	TRAFD GND
TX OFFS	18	TX OFFS
EXT MOD	19	GND
GND	20	GND
DC OPT	21	TRAFD 1:10
DEMOD OUT	22	AF OPT
GEN 2	23	GEN STOP
RX MOD	24	TX PWR
GND	25	GND
+15V	26	+15V
TX DEMOD	27	ANALYS CONTR
-15V	28	-15V
AF SUM	29	AF MONITOR
+5V (ANA)	30	+5V (ANA)
AF COUNT	31	GND
R MHz	32	GND

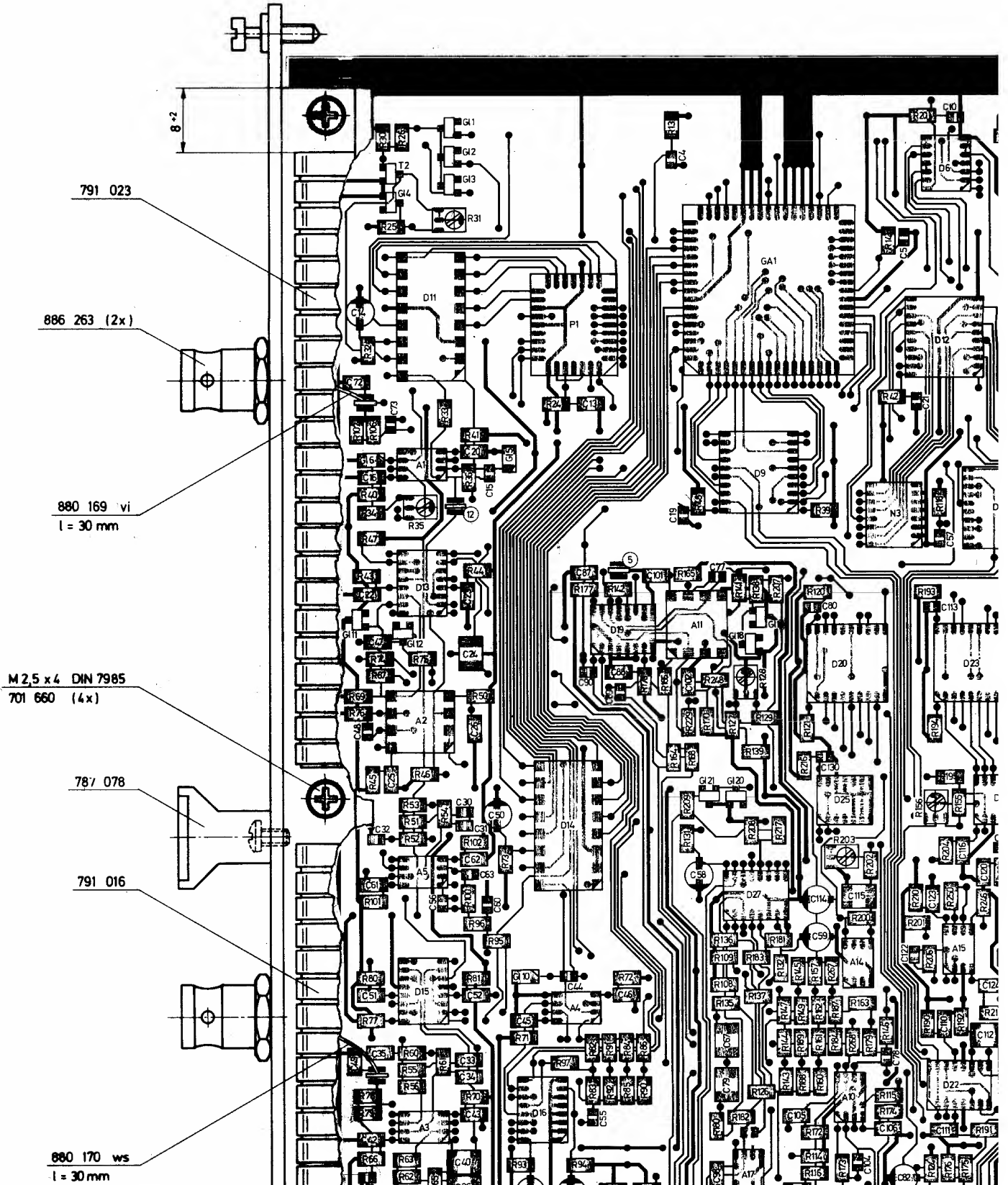

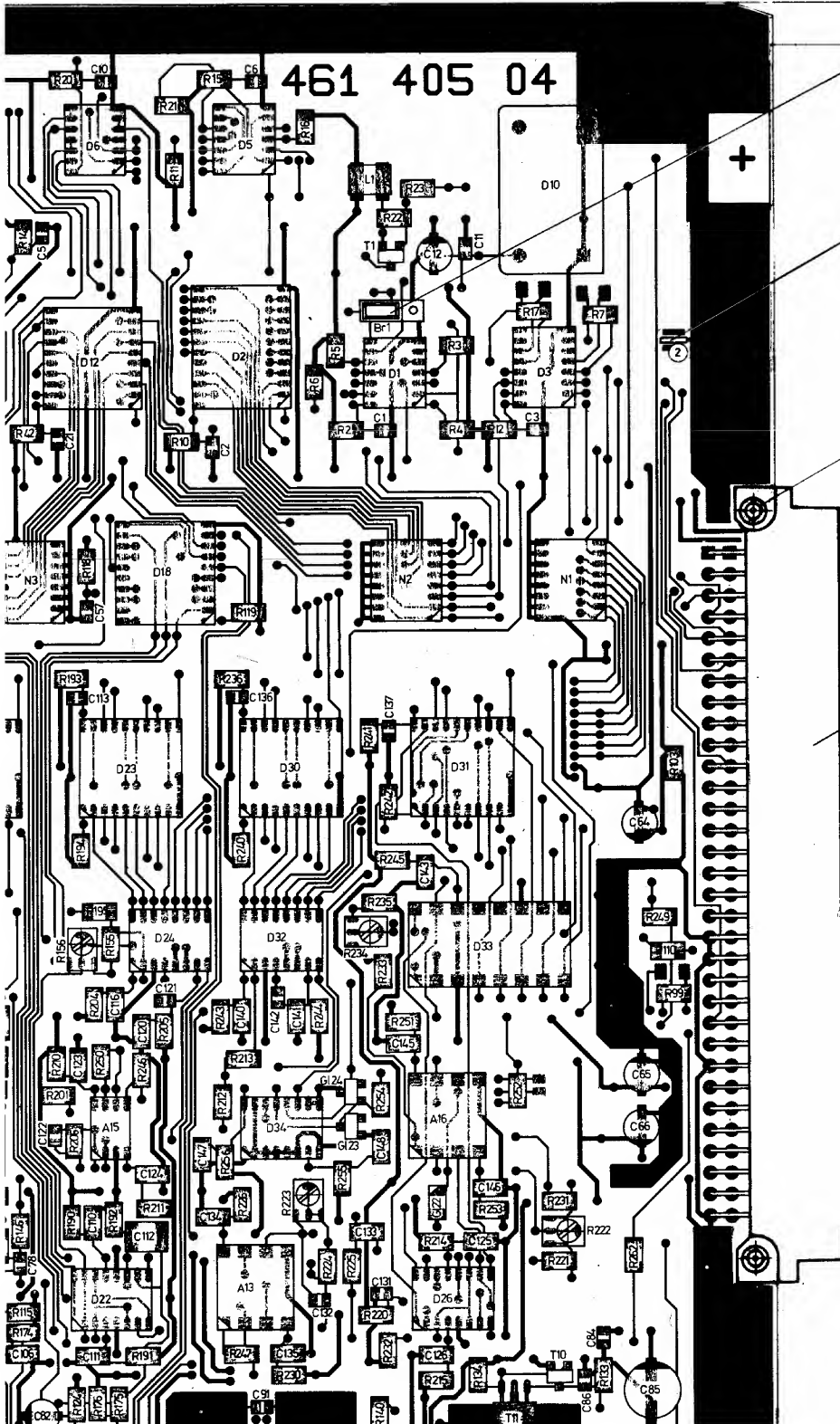

884 180  
884 182

786 009 (5x)

A 2,5 x 0,3 x 9 DIN 7340  
708 329 (2x)

884 500  
mit Schutzkappe 884 590 abgedeckt

Reflow gelötet  
hierzu Bauteilklebmaske 461 405 04  
C 68 / C 81 / C 144 in der  
Schaltung nicht enthalten

5

4

3

2

1



704 035 eingepreßt  
701 021

Bu 29

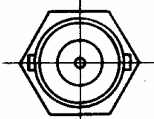

DC OUT

IN 7340

e 884 590 abgedeckt

477 701

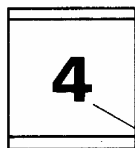

444 276

Bu 27

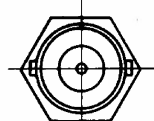

RX MOD

3 A 208 029

H

G

F

E

D

C

880 169 vi  
l = 30 mm

M 2,5 x 4 DIN 7985  
701 660 (4x)

787 078

791 016

880 170 ws  
l = 30 mm

10.2

Federklebeseite

chaltplanpositionierung  $\triangle$  208 029 S / Sa

13

12

11

10

9



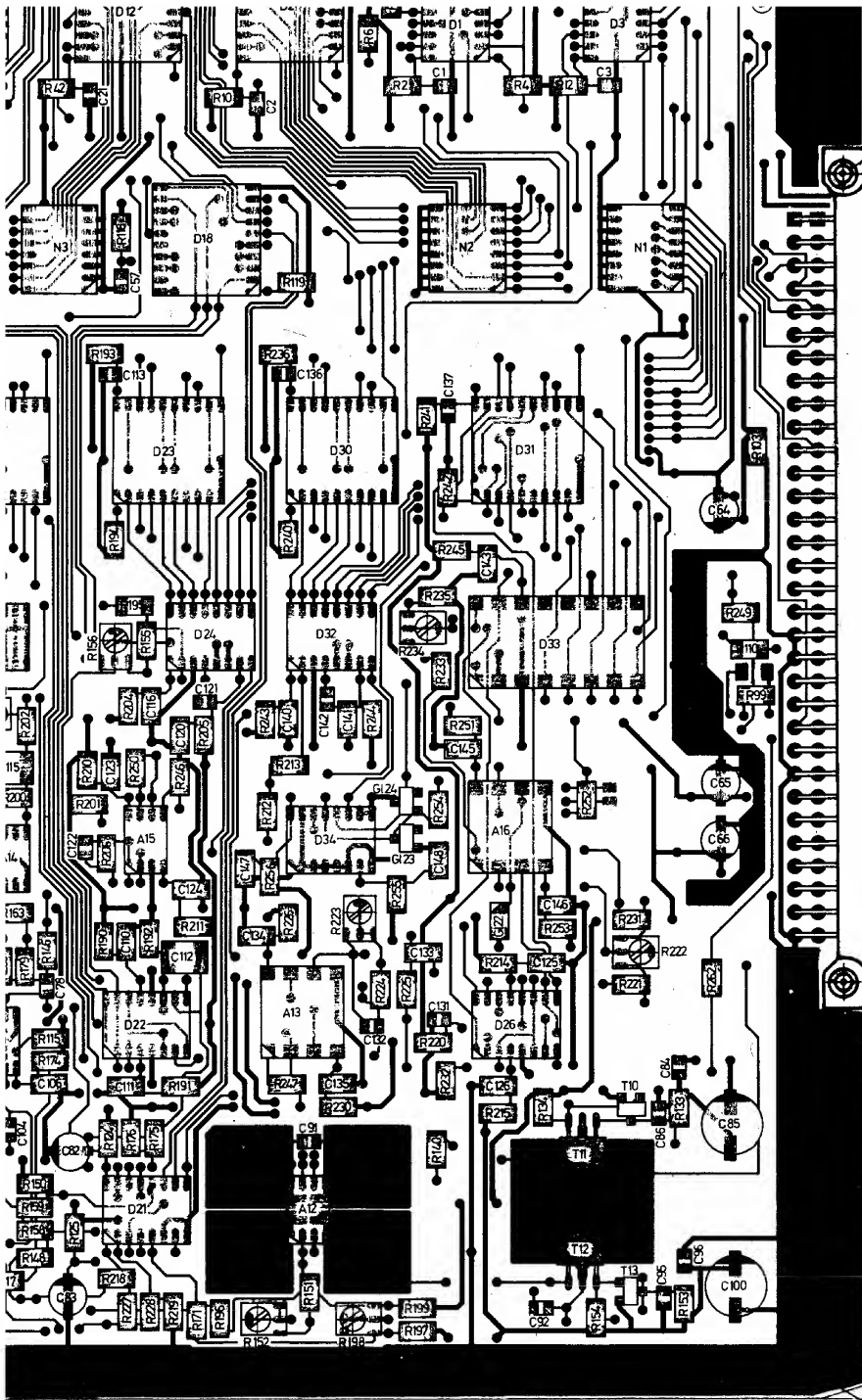

A 2,5 x 0,3 x 9 DIN 7340  
708 329 (2x)

884 500  
mit Schutzkappe 884 590 abgedeckt

beide Randstreifen  
vor dem Lötén abgedeckt



884 590 abgedeckt

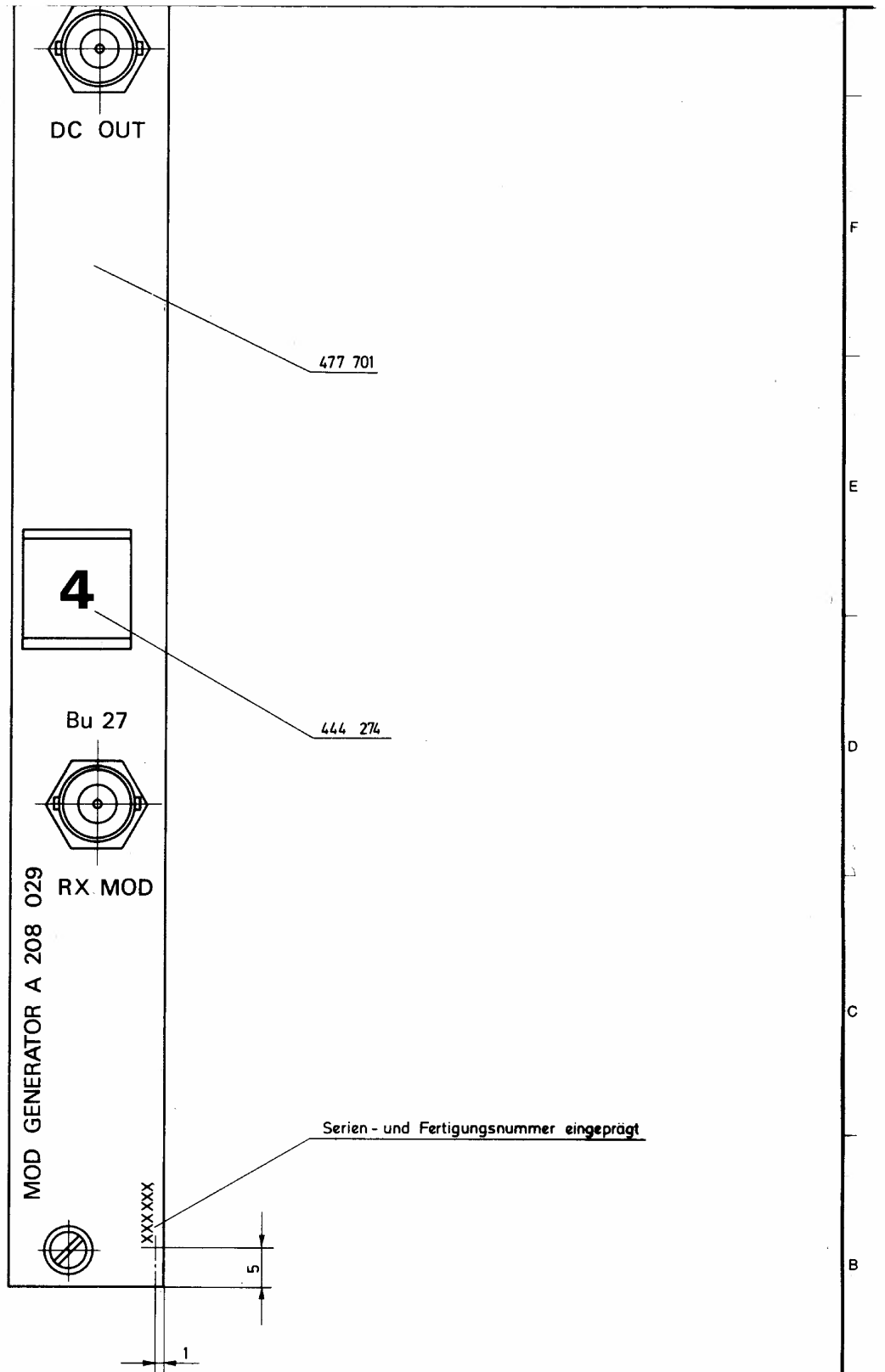

zn  
abgedeckt

= Kontrollmaß

10				Rohteil	Freimaß- toleranzen	Maßstab	Schlumberger o/s Meßgeräteeu u. Vertrieb GmbH 8 München 46
09						2:1	
08							MOD GENERATOR A
07				Werkstoff			
06	308,30	14,2	8	Reink			208 029
05	8088,22	11,2	88	Kr.			
04	7088,78	7,12	87	Kr.			
03	7088,70	23,1	87	Kr.			
02				Oberfläche	1987	Datum	Name
01					gez	20.11.87	Kr.
Ausgabe	Andg.	Datum	Name	bearb	23.11.87		
	Mitlig			gepr			
					Gerät: 4031 / 201 231		

1	2	3	4	5	6	7	8
Pos. REF. NO.	Wert VALUE	Bezeichnung Schlumberger PART. NO.	Hersteller MANUFACT	Pos. REF. NO.	Wert VALUE	Bezeichnung Schlumberger PART. NO.	Hersteller MANUFACT
A 1	TL 072 CD	834 222	TEX				
A 2	LF 412 ACN	834 212	NSC				
A 3							
A 4	TL 072 CD	834 222	TEX				
A 5				BR 1	385 0358 1 03 400	884 180	ETT
A 6	LF 412 ACN	834 212	NSC				
A 10	TL 072 CD	834 222	TEX				
A 11	LF 412 ACN	834 212	NSC				
A 12	NE 5534 AD	834 209	VALVO				
A 13	LF 412 ACN	834 212	NSC				
A 14	LM 385 M	834 244	NAT				
A 15	TL 072 CD	834 222	TEX				
A 16	LF 412 ACN	834 212	NSC				
A 17	TL 072 CD	834 222	TEX				
A 18	TL 072 CD	834 222	TEX				
				Bu 27	BNC 35/548	886 263	TELE
				Bu 29	BNC 35/548	886 263	TELE

07				Schlumberger Meßgeräte GmbH Ingoistädter Straße 67 a 8000 München 46			Schaltteilliste EL. PARTS LIST		Liste besteht LIST CONSISTS aus OF 11 Blatt SHEETS
06									
04	7088.169	19.11.87	Kr.						Blatt Nr. SHEET NO 1
03	7088.162	5.11.87	Di						
02	7088.09	24.7.87	Di						
01	6088.31	16.3.87	Di						
-	6088.53	10.11.86	Kr.	geschr.	30.10.86	Morasch	Bezeichnung Schlumberger PART. NO 208 029 Sa <sup>-</sup>		
Aus- gabe ISSUE	Änd- Mittig Nr. MODIFIC. NO	Tag DATE	Name NAME	bearb. g9dr.			Hierzu Schaltplan SEE CIRCUIT DIAGRAM 208 029 S	Gerät: 4031	

Diese Zeichnung ist unser Eigentum. Vervielfältigung, unbefugte Verwertung, Mitteilung an andere ist strafbar und schadenersatzpflichtig.

1	2			3	4	5	6		7	8	
Pos REF. NO	Wert VALUE			Bezeichnung Schlumberger PART. NO.	Hersteller MANUFACT	Pos. REF. NO	Wert VALUE		Bezeichnung Schlumberger PART. NO.	Hersteller MANUFACT	
						C 19	10 nF ± 10 % 50 V-	813 332	VITR		
						C 20	100 nF ± 10 % 50 V-	813 375	VITR		
						C 21	10 nF ± 10 % 50 V-	813 332	VITR		
						C 22	100 nF ± 10 % 50 V-	813 375	VITR		
						C 23	100 nF ± 10 % 50 V-	813 375	VITR		
						C 24	470 nF ± 10 % 50 V-	813 383	VITR		
						C 25	100 nF ± 10 % 50 V-	813 375	VITR		
						C 26	100 nF ± 10 % 50 V-	813 375	VITR		
C 1	10 nF ± 10 % 50 V-			813 332	VITR						
C 2	10 nF ± 10 % 50 V-			813 332	VITR						
C 3	10 nF ± 10, % 50 V-			813 332	VITR	C 30	560 pF ± 5 % 50 V-	813 244	VITR		
C 4	10 nF ± 10 % 50 V-			813 332	VITR	C 31	560 pF ± 5 % 50 V-	813 244	VITR		
C 5	10 nF ± 10 % 50 V-			813 332	VITR	C 32	560 pF ± 5 % 50 V-	813 244	VITR		
C 6	10 nF ± 10 % 50 V-			813 332	VITR	C 33	1,8 nF ± 5 % 50 V-	813 250	VITR		
						C 34	1,8 nF ± 5 % 50 V-	813 250	VITR		
						C 35	1,8 nF ± 5 % 50 V-	813 250	VITR		
						C 36	5,6 nF ± 5 % 50 V-	813 256	VITR		
C 10	10 nF ± 10 % 50 V-			813 332	VITR						
C 11	10 nF ± 10 % 50 V-			813 332	VITR						
C 12	10 µF ± 20 % 16 V-			814 382	RÖD						
C 13	100 nF ± 10 % 50 V-			813 375	VITR	C 40	5,6 nF ± 5 % 50 V-	813 256	VITR		
C 14	10 µF ± 20 % 16 V-			814 382	RÖD	C 41	5,6 nF ± 5 % 50 V-	813 256	VITR		
C 15	33 pF ± 5 % 50 V-			813 229	VITR	C 42	100 nF ± 10 % 50 V-	813 375	VITR		
C 16	100 nF ± 10 % 50 V-			813 375	VITR	C 43	100 nF ± 10 % 50 V-	813 375	VITR		
						C 44	27 pF ± 5 % 50 V-	813 228	VITR		
						C 45	100 nF ± 10 % 50 V-	813 375	VITR		
07				Schlumberger Meßgeräte GmbH Ingolstädter Straße 67 a 8000 München 46			Schaltteilliste EL. PARTS LIST			Liste besteht LIST CONSISTS OF 11 Blatt SHEETS	
06											Benennung DESCRIPTION MOD GENERATOR A
05							Bezeichnung Schlumberger PART. NO. 208 029 Sa				Blatt Nr. SHEET NO. 2
04							Hierzu Schaltplan SEE CIRCUIT DIAGRAM 208 029 S				
03				geschr.	30.10.86	Morasch	Gerät: 4031				
02	7088.98	24.7.87	Di	Tag DATE	Name NAME						
01	6088.31	16.3.87	Di								
-	6088.53	10.11.86	Kr.	bearb.							
Aus- gabe ISSUE	Änd.-Mittg. Nr. MODIFIC. NO	Tag DATE	Name NAME	gepr.							

Diese Zeichnung ist unser Eigentum. Vervielfältigung, unbefugte Verwertung, Mitteilung an andere ist strafbar und schadenersatzpflichtig.

1	2			3		4	5	6		7		8
Pos. REF. NO	Wert VALUE			Bezeichnung Schlumberger PART. NO.		Hersteller MANUFACT	Pos. REF. NO.	Wert VALUE		Bezeichnung Schlumberger PART. NO.		Hersteller MANUFACT
C 46	100 nF	± 10 %	50 V-	813 375	VITR	C 73	470 pF	± 5 %	50 V-	813 243	VITR	
C 47	100 nF	± 10 %	50 V-	813 375	VITR	C 74	100 nF	± 10 %	50 V-	813 375	VITR	
C 48	33 pF	± 5 %	50 V-	813 229	VITR	C 75	100 nF	± 10 %	50 V-	813 375	VITR	
C 49	1,2 nF	± 5 %	50 V-	813 248	VITR	C 76	470 pF	± 5 %	50 V-	813 243	VITR	
C 50	10 µF	± 20 %	16 V-	814 382	RÖD	C 77	22 pF	± 5 %	50 V-	813 227	VITR	
C 51	100 nF	± 10 %	50 V-	813 375	VITR	C 78	22 pF	± 5 %	50 V-	813 227	VITR	
C 52	100 nF	± 10 %	50 V-	813 375	VITR	C 79	470 nF	± 10 %	50 V-	813 383	VITR	
C 53	10 µF	± 20 %	16 V-	814 382	VITR	C 80	10 nF	± 10 %	50 V-	813 332	VITR	
C 54	10 µF	± 20 %	16 V-	814 382	RÖD							
C 55	22 pF	± 5 %	50 V-	813 227	VITR	C 82	10 µF	± 20 %	16 V-	814 382	RÖD	
C 56	270 pF	± 5 %	50 V-	813 240	VITR	C 83	10 µF	± 20 %	16 V-	814 382	RÖD	
C 57	10 nF	± 10 %	50 V-	813 332	VITR	C 84	10 nF	± 10 %	50 V-	813 332	VITR	
C 58	10 µF	± 20 %	16 V-	814 382	RÖD	C 85	47 µF	± 20 %	16 V-	814 386	RÖD	
C 59	10 µF	± 20 %	16 V-	814 382	RÖD	C 86	680 pF	± 5 %	50 V-	813 245	VITR	
C 60	180 pF	± 5 %	50 V-	813 238	VITR	C 87	100 nF	± 10 %	50 V-	813 375	VITR	
C 61	100 nF	± 10 %	50 V-	813 375	VITR	C 88	100 nF	± 10 %	50 V-	813 375	VITR	
C 62	100 nF	± 10 %	50 V-	813 375	VITR	C 89	270 pF	± 5 %	50 V-	813 240	VITR	
C 63	22 pF	± 5 %	50 V-	813 227	VITR	C 90	27 pF	± 5 %	50 V-	813 228	VITR	
C 64	10 µF	± 20 %	6,3 V	814 382	RÖD	C 91	47 pF	± 5 %	50 V-	813 231	VITR	
C 65	10 µF	± 20 %	16 V-	814 382	RÖD	C 92	27 pF	± 5 %	50 V-	813 228	VITR	
C 66	10 µF	± 20 %	16 V-	814 382	RÖD	C 93	22 pF	± 5 %	50 V-	813 227	VITR	
C 67	470 nF	± 10 %	50 V-	813 383	VITR	C 94	22 pF	± 5 %	50 V-	813 227	VITR	
						C 95	680 pF	± 5 %	50 V-	813 245	VITR	
C 69	22 pF	± 5 %	50 V-	813 227	VITR	C 96	10 nF	± 10 %	50 V-	813 332	VITR	
C 70	10 µF	± 20 %	16 V-	814 382	RÖD							
C 71	10 µF	± 20 %	16 V	814 382	RÖD	C 98	100 nF	± 10 %	50 V-	813 375	VITR	
C 72	1,2 nF	± 5 %	50 V-	813 248	VITR	C 99	100 nF	± 10 %	50 V-	813 375	VITR	

07				Schlumberger Meßgeräte GmbH Ingolstädter Straße 67 a 8000 München 46				Schaltteilliste EL. PARTS LIST Benennung DESCRIPTION MOD GENERATOR A				Liste besteht LIST CONSISTS aus OF 11 Blatt SHEETS
06												
05	7088.169	19.11.87	Kr.									
04	7088.129	1.9.87	Di									
03	7088.104	28.7.87	Mo.									
02	7088.98	24.7.87	Di									
01	6088.31	16.3.87	Di									
-	6088.53	10.11.86	Kr.	geschr.	30.10.86	Morasch						
Ausgabe ISSUE	And.-Mitgl. Nr. MODIFIC. NO	Tag DATE	Name NAME	bearb.			Bezeichnung Schlumberger PART NO	208 029 Sa				Blatt Nr. SHEET NO 3
				gepr.			Hierzu Schaltplan SEE CIRCUIT DIAGRAM	208 029 S				
							Gerät:	4031				

Diese Zeichnung ist unser Eigentum. Vervielfältigung, unbefugte Verwertung, Mitteilung an andere ist strafbar und schadenersatzpflichtig.

1	2	3	4	5	6	7	8
Pos. REF. NO.	Wert VALUE	Bezeichnung Schlumberger PART NO.	Hersteller MANUFACT	Pos. REF. NO.	Wert VALUE	Bezeichnung Schlumberger PART NO.	Hersteller MANUFACT
C 100	47 $\mu$ F $\pm$ 20 % 16 V-	814 386	RÖD				
C 101	100 nF $\pm$ 10 % 50 V-	813 375	VITR				
C 102	100 nF $\pm$ 10 % 50 V-	813 375	VITR				
				C 130	10 nF $\pm$ 10 % 50 V-	813 332	VITR
C 104	27 pF $\pm$ 5 % 50 V-	813 228	VITR	C 131	10 nF $\pm$ 10 % 50 V-	813 332	VITR
C 105	100 nF $\pm$ 10 % 50 V-	813 375	VITR	C 132	33 pF $\pm$ 5 % 50 V-	813 229	VITR
C 106	100 nF $\pm$ 10 % 50 V-	813 375	VITR	C 133	1,2 nF $\pm$ 5 % 50 V-	813 248	VITR
C 107	100 nF $\pm$ 10 % 50 V-	813 375	VITR	C 134	100 nF $\pm$ 10 % 50 V-	813 375	VITR
C 108	100 nF $\pm$ 10 % 50 V-	813 375	VITR	C 135	100 nF $\pm$ 10 % 50 V-	813 375	VITR
				C 136	10 nF $\pm$ 10 % 50 V-	813 332	VITR
C 110	100 nF $\pm$ 10 % 50 V-	813 375	VITR	C 137	10 nF $\pm$ 10 % 50 V-	813 332	VITR
C 111	100 nF $\pm$ 10 % 50 V-	813 375	VITR				
C 112	470 nF $\pm$ 10 % 50 V-	813 383	VITR				
C 113	10 nF $\pm$ 10 % 50 V-	813 332	VITR	C 140	100 nF $\pm$ 10 % 50 V-	813 375	VITR
C 114	10 $\mu$ F $\pm$ 20 % 16 V-	814 382	RÖD	C 141	100 nF $\pm$ 10 % 50 V-	813 375	VITR
C 115	470 nF $\pm$ 10 % 50 V-	813 383	VITR	C 142	100 pF $\pm$ 5 % 50 V-	813 235	VITR
C 116	100 nF $\pm$ 10 % 50 V-	813 375	VITR	C 143	100 nF $\pm$ 10 % 50 V-	813 375	VITR
				C 145	100 nF $\pm$ 10 % 50 V-	813 375	VITR
				C 146	100 nF $\pm$ 10 % 50 V-	813 375	VITR
C 120	100 nF $\pm$ 10 % 50 V-	813 375	VITR	C 147	100 nF $\pm$ 10 % 50 V-	813 375	VITR
C 121	100 pF $\pm$ 5 % 50 V-	813 235	VITR	C 148	100 nF $\pm$ 10 % 50 V-	813 375	VITR
C 122	27 pF $\pm$ 5 % 50 V-	813 228	VITR				
C 123	100 nF $\pm$ 10 % 50 V-	813 375	VITR				
C 124	100 nF $\pm$ 10 % 50 V-	813 375	VITR				
C 125	100 nF $\pm$ 10 % 50 V-	813 375	VITR				
C 126	100 nF $\pm$ 10 % 50 V-	813 375	VITR				

07				Schlumberger Meßgeräte GmbH Ingolstädter Straße 67 a 8000 München 46			Schaltteilliste EL. PARTS LIST		Liste besteht LIST CONSISTS aus OF 11 Blatt SHEETS Blatt Nr. SHEET NO. 4		
06			Benennung DESCRIPTION							MOD GENERATOR A	
05							Tag DATE	Name NAME		Bezeichnung Schlumberger PART NO	208 029 Sa
04							geschr bearb gepr	30.10.86		Morasch	Hierzu Schaltplan SEE CIRCUIT DIAGRAM
03	7088.162	5.11.87	Di					Gerät: 4031			
02	7088.98	24.7.87	Di								
01	6088.31	16.3.87	Di								
-	6088.53	10.11.86	Kr.								
Ausgabe ISSUE	And.-Mittg. Nr MODIFIC. NO.	Tag DATE	Name NAME								

Diese Zeichnung ist unser Eigentum. Vervielfältigung, unbefugte Verwertung, Mitteilung an andere ist strafbar und schadenersatzpflichtig.

1	2			3		4	5	6		7		8			
Pos. REF. NO	Wert VALUE			Bezeichnung Schlumberger PART. NO.		Hersteller MANUFACT	Pos. REF. NO.	Wert VALUE		Bezeichnung Schlumberger PART. NO		Hersteller MANUFACT			
D 1	PC 74 HCT 74 T			834 433		VAL									
D 2	PC 74 HCT 4514 T			834 443		VAL									
D 3	PC 74 HCT 139 T			834 435		VAL	D 30	PC 74 HCT 374 T		834 437		VAL			
							D 31	PC 74HCT 374 T		834 437		VAL			
D 5	PC 74 HCT 74 T			834 433		VAL	D 32	DAC 08 ED		834 136		NS			
D 6	PC 74 HCT 02 T			834 431		VAL	D 33	AD 7523 LN		834 123		ANA			
							D 34	HEF 4053 BT		834 442		VAL			
D 9	PC 74 HCT 374 T			834 437		VAL									
D 10	MCO 4515 B			853 301		ELEC									
D 11	AD 7524 JN			834 131		DEV	GA 1	L 5 A 0190 S		835 100		LSI			
D 12	PC 74 HCT 244 T			834 436		VAL									
D 13	DG 211 CY			834 471		SILI									
D 14	AD 7533 LN			834 124		ANA									
D 15	DG 211 CY			834 471		SILI									
D 16	HEF 4052 BT			834 441		VAL	G1 1	BAS 16		830 552		VAL			
							G1 2	BAS 16		830 552		VAL			
D 18	PC 74 HCT 374 T			834 437		VAL	G1 3	BAS 16		830 552		VAL			
D 19	HEF 4053 BT			834 442		VAL	G1 4	BZX 84 C 5 V 1		830 492		VAL			
D 20	PC 74 HCT 374 T			834 437		VAL	G1 5	LL 103 B		830 517		ITT			
D 21	HEF 4053 BT			834 442		VAL	G1 6	LL 103 B		830 517		ITT			
D 22	DG 211 CY			834 471		SILI									
D 23	PC 74 HCT 374 T			834 437		VAL									
D 24	DAC 08 ED			834 136		NS									
D 25	PC 74 HCT 02 T			834 431		VAL	G1 10	LL 103 B		830 517		ITT			
D 26	DG 211 CY			834 471		SILI	G1 11	HS MS 2910		830 551		HP			
D 27	HEF 4053 BT			834 442		VAL	G1 12	HS MS 2910		830 551		HP			
07				Schlumberger Meßgeräte GmbH Ingolstädter Straße 67 a 8000 München 46			Schaltteilliste EL. PARTS LIST					Liste besteht LIST CONSISTS aus OF 11 Blatt SHEETS			
06													Benennung DESCRIPTION MOD GENERATOR A		
05	7088.163	19.11.87	Kr.				Tag DATE			Name NAME			Bezeichnung Schlumberger PART NO 208 029 Sa		Blatt Nr SHEET NO
04	7088.133	8.9.87	Di												
03	7088.104	27.7.87	Mo.	bearb gedr		Gerät: 4031		5							
02	7088.98	24.7.87	Di							Ausgabe ISSUE		And-Mittig. Nr MODIFIC. NO		Tag DATE	
01	6088.31	16.3.87	Di												
	6088.53	10.11.86	Kr.												

Diese Zeichnung ist unser Eigentum. Vervielfältigung, unbefugte Verwertung, Mitteilung an andere ist strafbar und schadenersatzpflichtig

1	2	3	4	5	6	7	8
Pos. REF. NO	Wert VALUE	Bezeichnung Schlumberger PART NO.	Hersteller MANUFACT	Pos. REF. NO.	Wert VALUE	Bezeichnung Schlumberger PART NO.	Hersteller MANUFACT
G1 13	BZX 84 C 6 V 8	830 494	VAL	N 3	8x100 kΩ ± 5 %	804 511	DALE
G1 14	BZX 84 C 6 V 8	830 494	VAL				
G1 18	BAS 16	830 552	VAL	P 1	N 27 C 64-25	893 330	SCHL
G1 19	BAS 16	830 552	VAL				
G1 20	BAS 16	830 552	VAL				
G1 21	BAS 16	830 552	VAL				
G1 22	LL 103 B	830 517	ITT				
G1 23	BAS 16	830 552	VAL				
G1 24	BAS 16	830 552	VAL	R 2	10 Ω ± 1 %	802 713	BEY
				R 3	1 kΩ ± 1 %	802 737	BEY
				R 4	1 kΩ ± 1 %	802 737	BEY
				R 5	1 kΩ ± 1 %	802 737	BEY
L 1	100 μH ± 15 %	821 322	SIE	R 6	1 kΩ ± 1 %	802 737	BEY
				R 7	10 Ω ± 1 %	802 713	BEY
				R 10	10 Ω ± 1 %	802 713	BEY
				R 11	47 kΩ ± 1 %	802 757	BEY
				R 12	10 Ω ± 1 %	802 713	BEY
				R 13	10 Ω ± 1 %	802 713	BEY
				R 14	10 Ω ± 1 %	802 713	BEY
				R 15	10 Ω ± 1 %	802 713	BEY
N 1	8x100 kΩ ± 5 %	804 511	DALE	R 16	1 kΩ ± 1 %	802 737	BEY
N 2	8x100 kΩ ± 5 %	804 511	DALE	R 17	10 Ω ± 1 %	802 713	BEY

07				Schlumberger Meßgeräte GmbH Ingolstädter Straße 67 a 8000 München 46			Schaltteilliste EL. PARTS LIST		Liste besteht LIST CONSISTS aus OF 11 Blatt SHEETS
06									
04	7088.169	19.11.87	Kr.	Tag DATE	Name NAME	Bezeichnung Schlumberger PART NO	208 029 Sa	Blatt Nr. SHEET NO	
03	7088.162	5.11.87	Di						geschr
02	7088.93	24.7.87	Di	bearb.	31.10.87	Morasch	Gerät: 4031		
01	6088.31	16.3.87	Di					gepr.	
-	6088.53	10.11.86	Kr.						
Ausgabe ISSUE	Änd.-Mittlg. Nr MODIFIC. NO	Tag DATE	Name NAME					6	

Diese Zeichnung ist unser Eigentum. Vervielfältigung, unbefugte Verwertung, Mitteilung an andere ist strafbar und schadenersatzpflichtig.



1	2			3	4	5	6		7	8
Pos REF. NO	Wert VALUE			Bezeichnung Schlumberger PART NO.	Hersteller MANUFACT	Pos REF. NO	Wert VALUE		Bezeichnung Schlumberger PART NO	Hersteller MANUFACT
						R 45	10 Ω ± 1 %		802 713	BEY
						R 46	100 kΩ ± 1 %		802 761	BEY
R 20	10 Ω ± 1 %			802 713	BEY	R 47	10 kΩ ± 1 %		802 749	BEY
R 21	1 kΩ ± 1 %			802 737	BEY	R 48	10 Ω ± 1 %		802 713	BEY
R 22	4,7 kΩ ± 1 %			802 745	BEY					
R 23	1,8 kΩ ± 1 %			802 740	BEY	R 50	10 Ω ± 1 %		802 713	BEY
R 24	10 Ω ± 1 %			802 713	BEY	R 51	56 kΩ ± 1 %		802 758	BEY
R 25	1,8 kΩ ± 1 %			802 740	BEY	R 52	100 kΩ ± 1 %		802 761	BEY
R 26	6,8 kΩ ± 1 %			802 747	BEY	R 53	15 kΩ ± 1 %		802 751	BEY
						R 54	15 kΩ ± 1 %		802 751	BEY
						R 55	68 kΩ ± 1 %		802 759	BEY
						R 56	56 kΩ ± 1 %		802 758	BEY
R 30	6,8 kΩ ± 1 %			802 747	BEY					
R 31	2 kΩ ± 25 %			807 738	BOUR					
R 32	10 Ω ± 1 %			802 713	BEY					
R 33	1 kΩ ± 1 %			802 737	BEY	R 60	15 kΩ ± 1 %		802 751	BEY
R 34	4,7 kΩ ± 1 %			802 745	BEY	R 61	15 kΩ ± 1 %		802 751	BEY
R 35	100 Ω ± 25 %			807 734	BOU	R 62	56 kΩ ± 1 %		802 758	BEY
R 36	4,7 kΩ ± 1 %			802 745	BEY	R 63	68 kΩ ± 1 %		802 759	BEY
						R 64	15 kΩ ± 1 %		802 751	BEY
						R 65	15 kΩ ± 1 %		802 751	BEY
R 39	1 kΩ ± 1 %			802 737	BEY	R 66	10 Ω ± 1 %		802 713	BEY
R 40	10 Ω ± 1 %			802 713	BEY					
R 41	10 Ω ± 1 %			802 713	BEY					
R 42	10 Ω ± 1 %			802 713	BEY	R 69	680 kΩ ± 1 %		802 771	BEY
R 43	10 Ω ± 1 %			802 713	BEY	R 70	10 Ω ± 1 %		802 713	BEY
R 44	10 Ω ± 1 %			802 713	BEY	R 71	10 Ω ± 1 %		802 713	BEY
07				Schlumberger Meßgeräte GmbH Ingolstädter Straße 67a 8000 München 46			Schaltteilliste EL. PARTS LIST			Liste besteht LIST CONSISTS aus OF 11 Blatt SHEETS
06										
05										
04	7088.129	1.9.87	Di							
03	7088.104	28.7.87	Mo							
02	7088.98	24.7.87	Di							
01	6088.21	16.3.87	Di							
-	6088.53	10.11.86	Kr.	geschr.	31.10.86	Morasch	Bezeichnung Schlumberger PART NO	208 029 Sa		Blatt Nr SHEET NO  7
Aus- gabe ISSUE	And.-Mittig Nr MODIFIC. NO	Tag DATE	Name NAME	bearb.			Hierzu Schaltplan SEE CIRCUIT DIAGRAM	208 029 S		
				gepr.			Gerät: 4031			

Diese Zeichnung ist unser Eigentum. Vervielfältigung, unbefugte Verwertung, Mitteilung an andere ist strafbar und schadenersatzpflichtig.

1	2	3	4	5	6	7	8
Pos. REF NO	Wert VALUE	Bezeichnung Schlumberger PART NO.	Hersteller MANUFACT	Pos. REF. NO.	Wert VALUE	Bezeichnung Schlumberger PART NO.	Hersteller MANUFACT
R 72	10 Ω ± 1 %	802 713	BEY	R 99	10 Ω ± 1 %	802 713	BEY
R 73	10 Ω ± 1 %	802 713	BEY	R 100	10 kΩ ± 1 %	802 749	BEY
R 74	15 kΩ ± 0,25 %	802 851	BEY	R 101	10 Ω ± 1 %	802 713	BEY
R 75	1,2 kΩ ± 1 %	802 738	BEY	R 102	10 Ω ± 1 %	802 713	BEY
R 76	10 kΩ ± 0,25 %	802 849	BEY	R 103	10 Ω ± 1 %	802 713	BEY
R 77	1 kΩ ± 1 %	802 737	BEY	R 104	1,5 kΩ ± 1 %	802 739	BEY
R 78	1,5 kΩ ± 1 %	802 739	BEY	R 105	1,5 kΩ ± 1 %	802 739	BEY
R 79	1 kΩ ± 1 %	802 737	BEY	R 106	1,5 kΩ ± 1 %	802 739	BEY
R 80	10 Ω ± 1 %	802 713	BEY	R 107	1 kΩ ± 1 %	802 737	BEY
R 81	10 Ω ± 1 %	802 713	BEY	R 108	82 kΩ ± 1 %	802 760	BEY
R 82	100 kΩ ± 0,25 %	802 861	BEY	R 109	100 kΩ ± 1 %	802 761	BEY
R 83	200 Ω ± 0,25 %	802 886	BEY	R 110	10 Ω ± 1 %	802 713	BEY
R 84	100 kΩ ± 0,25 %	802 861	BEY				
R 85	2 kΩ ± 0,25 %	802 887	BEY				
R 86	10 kΩ ± 0,25 %	802 849	BEY				
R 87	680 Ω ± 1 %	802 735	BEY	R 114	10 Ω ± 1 %	802 713	BEY
				R 115	10 Ω ± 1 %	802 713	BEY
				R 116	10 Ω ± 1 %	802 713	BEY
R 90	2 kΩ ± 0,25 %	802 887	BEY	R 117	10 Ω ± 1 %	802 713	BEY
R 91	10 kΩ ± 0,25 %	802 849	BEY	R 118	10 Ω ± 1 %	802 713	BEY
R 92	10 kΩ ± 0,25 %	802 849	BEY	R 119	1 kΩ ± 1 %	802 737	BEY
R 93	10 Ω ± 1 %	802 713	BEY	R 120	10 Ω ± 1 %	802 713	BEY
R 94	10 Ω ± 1 %	802 713	BEY	R 121	1 kΩ ± 1 %	802 737	BEY
R 95	10 kΩ ± 1 %	802 749	BEY				
R 96	10 kΩ ± 1 %	802 749	BEY				
R 97	3,3 kΩ ± 1 %	802 743	BEY	R 124	10 Ω ± 1 %	802 713	BEY
				R 125	10 Ω ± 1 %	802 713	BEY

07				Schlumberger Meßgeräte GmbH Ingolstädter Straße 67a 8000 München 46			Schaltteilliste EL. PARTS LIST		Liste besteht LIST CONSISTS
06									
05	7088.169	19.11.87	Kr.	Tag DATE		Name NAME		Bezeichnung Schlumberger PART NO	Blatt Nr SHEET NO.
04	7088.162	5.11.87	Di						
03	7088.104	28.7.87	Mo.	geschr.		31.10.86		Morasch	8
02	7088.98	24.7.87	Di	bearb.					
01	6088.31	16.3.87	Di	gepr.					
-	6088.53	10.11.86	Kr.						
Ausgabe ISSUE	And-Mittig. Nr MODIFIC NO	Tag DATE	Name NAME						

Diese Zeichnung ist unser Eigentum. Vervielfältigung, unbefugte Verwertung, Mitteilung an andere ist strafbar und schadenersatzpflichtig.

1	2	3	4	5	6	7	8
Pos. REF. NO.	Wert VALUE	Bezeichnung Schlumberger PART. NO.	Hersteller MANUFACT	Pos. REF. NO.	Wert VALUE	Bezeichnung Schlumberger PART. NO.	Hersteller MANUFACT
R 126	100 kΩ ± 1 %	802 761	BEY	R 153	100 Ω ± 1 %	802 725	BEY
R 127	15 kΩ ± 1 %	802 751	BEY	R 154	15 Ω ± 1 %	802 715	BEY
R 128	100 Ω ± 25 %	807 734	BOUR	R 155	12 kΩ ± 1 %	802 750	BEY
R 129	15 kΩ ± 1 %	807 751	BEY	R 156	2 kΩ ± 25 %	807 738	BOUR
				R 157	560 Ω ± 1 %	802 734	BEY
R 131	10 Ω ± 1 %	802 713	BEY	R 158	15 kΩ ± 1 %	802 751	BEY
R 132	10 Ω ± 1 %	802 713	BEY	R 159	2,7 kΩ ± 1 %	802 742	BEY
R 133	100 Ω ± 1 %	802 725	BEY	R 160	15 kΩ ± 0,25 %	802 851	BEY
R 134	15 Ω ± 1 %	802 715	BEY	R 161	560 Ω ± 1 %	802 734	BEY
R 135	100 kΩ ± 1 %	802 761	BEY	R 162	15 kΩ ± 0,25 %	802 851	BEY
R 136	1,8 kΩ ± 1 %	802 740	BEY	R 163	20 kΩ ± 0,25 %	802 888	BEY
R 137	2,2 kΩ ± 1 %	802 741	BEY	R 164	22 kΩ ± 0,25 %	802 853	BEY
R 138	10 kΩ ± 1 %	802 749	BEY	R 165	10 Ω ± 1 %	802 713	BEY
R 139	1,8 kΩ ± 1 %	802 740	BEY	R 166	100 Ω ± 1 %	802 725	BEY
R 140	10 Ω ± 1 %	802 713	BEY				
R 141	10 kΩ ± 1 %	802 749	BEY	R 168	2,2 kΩ ± 1 %	802 741	BEY
R 142	2,2 kΩ ± 1 %	802 741	BEY				
R 143	560 Ω ± 1 %	802 734	BEY	R 170	10 Ω ± 1 %	802 713	BEY
R 144	15 kΩ ± 0,25 %	802 851	BEY	R 171	6,8 kΩ ± 1 %	802 747	BEY
R 145	560 Ω ± 1 %	802 734	BEY	R 172	10 Ω ± 1 %	802 713	BEY
R 146	20 kΩ ± 0,25 %	802 888	BEY	R 173	100 Ω ± 1 %	802 725	BEY
R 147	3,9 kΩ ± 1 %	802 744	BEY	R 174	10 Ω ± 1 %	802 713	BEY
R 148	10 kΩ ± 1 %	802 749	BEY	R 175	22 kΩ ± 1 %	802 753	BEY
R 149	15 kΩ ± 0,25 %	802 851	BEY	R 176	1,8 kΩ ± 1 %	802 740	BEY
R 150	1,8 kΩ ± 1 %	802 740	BEY	R 177	10 Ω ± 1 %	802 713	BEY
R 151	20 kΩ ± 0,25 %	802 888	BEY	R 178	10 Ω ± 1 %	802 713	BEY
R 152	5 kΩ ± 25 %	807 739	BOUR	R 179	3,9 kΩ ± 1 %	802 744	BEY

07	7088.169	19.11.87	Kr.	Schlumberger Meßgeräte GmbH Ingolstädter Straße 67a 8000 München 46	Schaltteilliste EL. PARTS LIST		Liste besteht LIST CONSISTS aus OF 11 Blatt SHEETS
06	7088.162	5.11.87	Di				
05	7088.129	1.9.87	Di		Bezeichnung Schlumberger PART NO 208 029 Sa	Blatt Nr SHEET NO 9	
04	7088.112	7.8.87	Mo.				
03	7088.104	28.7.87	Mo.		gerät: 4031		
02	7088.98	24.7.87	Di	1987	Tag DATE 16.3.87	Name NAME Dietrich	
01	6088.31	16.3.87	Di	geschr.	bearb.	gedr.	
Ausgabe ISSUE	Änd.-Mittig Nr MODIFIC NO	Tag DATE	Name NAME				

Diese Zeichnung ist unser Eigentum. Vervielfältigung, unbefugte Verwertung, Mitteilung an andere ist strafbar und schadenersatzpflichtig

1	2			3	4	5	6		7		8
Pos. REF. NO	Wert VALUE			Bezeichnung Schlumberger PART. NO.	Hersteller MANUFACT	Pos. REF. NO	Wert VALUE		Bezeichnung Schlumberger PART. NO.	Hersteller MANUFACT	
R 180	100 kΩ ± 1 %			802 761	BEY	R 207	10 kΩ ± 1 %		802 749	BEY	
R 181	1,8 kΩ ± 1 %			802 740	BEY	R 208	1,8 kΩ ± 1 %		802 740	BEY	
R 182	120 kΩ ± 1 %			802 762	BEY	R 209	12 kΩ ± 1 %		802 750	BEY	
R 183	2,2 kΩ ± 1 %			802 741	BEY	R 210	10 Ω ± 1 %		802 713	BEY	
R 184	20 kΩ ± 0,25 %			802 888	BEY	R 211	10 Ω ± 1 %		802 713	BEY	
R 185	6,8 kΩ ± 1 %			802 747	BEY	R 212	220 Ω ± 1 %		802 729	BEY	
						R 213	6,8 kΩ ± 1 %		802 747	BEY	
R 187	15 kΩ ± 0,25 %			802 851	BEY	R 214	10 Ω ± 1 %		802 713	BEY	
R 188	15 kΩ ± 0,25 %			802 851	BEY	R 215	10 Ω ± 1 %		802 713	BEY	
R 189	560 Ω ± 1 %			802 734	BEY	R 216	10 Ω ± 1 %		802 713	BEY	
R 190	10 Ω ± 1 %			802 713	BEY	R 217	2,2 kΩ ± 1 %		802 741	BEY	
R 191	10 Ω ± 1 %			802 713	BEY	R 218	10 kΩ ± 1 %		802 749	BEY	
R 192	100 kΩ ± 1 %			802 761	BEY	R 219	1,8 kΩ ± 1 %		802 740	BEY	
R 193	10 Ω ± 1 %			802 713	BEY	R 220	10 Ω ± 1 %		802 713	BEY	
R 194	1 kΩ ± 1 %			802 737	BEY	R 221	47 kΩ ± 1 %		802 757	BEY	
R 195	8,2 kΩ ± 1 %			802 746	BEY	R 222	1 kΩ ± 25 %		807 737	BOU	
R 196	6,8 kΩ ± 1 %			802 747	BEY	R 223	50 kΩ ± 25 %		807 742	BOU	
R 197	15 kΩ ± 1 %			802 751	BEY	R 224	120 kΩ ± 1 %		802 762	BEY	
R 198	100 Ω ± 25 %			807 734	BOUR	R 225	3,3 kΩ ± 1 %		802 743	BEY	
R 199	15 kΩ ± 1 %			802 751	BEY	R 226	10 Ω ± 1 %		802 713	BEY	
R 200	8,2 kΩ ± 1 %			802 747	BEY	R 227	12 kΩ ± 1 %		802 750	BEY	
R 201	5,6 kΩ ± 1 %			802 746	BEY	R 228	2,2 kΩ ± 1 %		802 741	BEY	
R 202	10 kΩ ± 1 %			802 752	BEY	R 229	27 kΩ ± 1 %		802 754	BEY	
R 203	5 kΩ ± 25 %			807 739	BOU	R 230	10 Ω ± 1 %		802 713	BEY	
R 204	10 Ω ± 1 %			802 713	BEY	R 231	47 kΩ ± 1 %		802 757	BEY	
R 205	10 Ω ± 1 %			802 713	BEY	R 232	100 kΩ ± 1 %		802 761	BEY	
R 206	3,2 kΩ ± 1 %			802 743	BEY	R 233	3,3 kΩ ± 1 %		802 743	BEY	
07	7088.163	19.11.87	Kr.	Schlumberger Meßgeräte GmbH Ingolstädter Straße 67a 8000 München 46			Schaltteilliste EL. PARTS LIST			Liste besteht LIST CONSISTS aus OF 11 Blatt SHEETS Blatt Nr. SHEET NO 10	
06	7088.162	5.11.87	Di								Benennung DESCRIPTION MOD GENERATOR A
05	7088.121	4.2.87	Di				Bezeichnung Schlumberger PART NO 208 029 Sa				
04	7088.122	1.9.87	Di				Hierzu Schaltplan SEE CIRCUIT DIAGRAM 208 029 S				
03	7088.112	1.8.87	Kr.				Gerät: 4031				
02	7088.93	24.7.87	Di								
01	6088.21	16.3.87	Di								
-	6088.53	10.11.86	Kr.	geschr.	21.10.86	Horasch					
Ausgabe ISSUE	And-Mittig. Nr. MODIFIC. NO	Tag DATE	Name NAME	bearb.							
				gepr.							

Diese Zeichnung ist unser Eigentum. Vervielfältigung, unbefugte Verwertung, Mitteilung an andere ist strafbar und schadenersatzpflichtig.

1	2	3	4	5	6	7	8
Pos REF. NO	Wert VALUE	Bezeichnung Schlumberger PART. NO.	Hersteller MANUFACT	Pos REF. NO	Wert VALUE	Bezeichnung Schlumberger PART. NO.	Hersteller MANUFACT
R 234	100 Ω ± 25 %	807 734	BOU				
R 235	820 Ω ± 1 %	802 736	BEY	R 262	10 Ω ± 1 %	802 713	BEY
R 236	10 Ω ± 1 %	802 713	BEY	R 263	10 kΩ ± 1 %	802 749	BEY
R 237	4,7 kΩ ± 1 %	802 745	BEY	R 264	10 kΩ ± 1 %	802 749	BEY
R 238	4,7 kΩ ± 1 %	802 745	BEY	R 265	10 kΩ ± 1 %	802 749	BEY
R 239	4,7 kΩ ± 1 %	802 745	BEY	R 266	10 Ω ± 1 %	802 713	BEY
R 240	1 kΩ ± 1 %	802 737	BEY	R 267	560 Ω ± 1 %	802 734	BEY
R 241	10 Ω ± 1 %	802 713	BEY	R 268	3,9 kΩ ± 1 %	802 744	BEY
R 242	1 kΩ ± 1 %	802 737	BEY				
R 243	10 Ω ± 1 %	802 713	BEY	R 270	100 Ω ± 1 %	802 725	BEY
R 244	10 Ω ± 1 %	802 713	BEY	R 271	10 Ω ± 1 %	802 713	BEY
R 245	10 Ω ± 1 %	802 713	BEY	St 64	C42 334-A191-A521	884 500	SIE
R 246	15 kΩ ± 1 %	802 751	BEY	T 1	BC 860 B	832 285	SIE
R 247	100 Ω ± 1 %	802 725	BEY	T 2	BC 850 B	832 284	SIE
R 248	27 kΩ ± 1 %	802 754	BEY				
R 249	100 Ω ± 1 %	802 725	BEY				
R 250	100 Ω ± 1 %	802 725	BEY				
R 251	10 Ω ± 1 %	802 713	BEY				
R 252	100 Ω ± 1 %	802 725	BEY				
R 253	10 Ω ± 1 %	802 713	BEY				
R 254	10 kΩ ± 1 %	802 749	BEY				
R 255	10 Ω ± 1 %	802 713	BEY	T 10	BC 860 B	832 285	SIE
R 256	10 Ω ± 1 %	802 713	BEY	T 11	BCX 51 -16	832 283	VAL
R 257	1 kΩ ± 25 %	807 737	BOU	T 12	BCX 54-16	832 289	VAL
R 258	1 kΩ ± 25 %	807 737	BOU	T 13	BC 850 B	832 284	SIE
R 259	1 kΩ ± 25 %	807 737	BOU				

07	7088.174	27.11.87	Kr.	Schlumberger Meßgeräte GmbH Ingolstädter Straße 67 a 8000 München 46	Schaltteilliste EL. PARTS LIST		Liste besteht LIST CONSISTS aus OF 11 Blatt SHEETS Blatt Nr. SHEET NO. 11
06	7088.169	19.11.87	Kr.				
05	7088.162	5.11.87	Di		Benennung DESCRIPTION MOD GENERATOR A		
04	7088.112	7.3.87	Mo.		Bezeichnung Schlumberger PART NO 208 029 Sa		
03	7088.104	28.7.87	Mo.			Hierzu Schaltplan SEE CIRCUIT DIAGRAM 208 029 S	
02	7088.98	24.7.87	Di		geschr. 31.10.86 Morasch bearb. gepr.		
01	6088.31	16.3.87	Di				
-	6088.53	10.11.86	Kr.				
Ausgabe ISSUE	Änd.-Mitgl. Nr. MODIFIC. NO.	Tag DATE	Name NAME				

Diese Zeichnung ist unser Eigentum. Vervielfältigung, unbefugte Verwertung, Mitteilung an andere ist strafbar und schadenersatzpflichtig.

## 1. Modulation generator B (option)

Modulation generator B is of the same design as modulation generator A. The same circuit board is used for both versions. Only the components determine whether modulation generator A or modulation generator B is concerned:

- R8 and R9 set the board decoder for generator B (R7, R17 for generator A).
- R111 conducts the output signal from generator B to connector St64/23a (on generator A R99 configures connector St64/23a as the generator B input).
- Those components not necessary for the functioning of generator B are omitted.

### 1.1 Sinewave generator

See block diagram of generator B and description under section 1 for generator A.

### 1.2 Electronic attenuator (level control)

See block diagram of generator B and description under section 1.3 for generator A.

### 1.3 Lowpass filter

See block diagram of generator B and description under section 1.4 for generator A.

### 1.4 Frequency ranges

See description under section 1.5 for generator A.

Ref. No. 208 032 F	Sub Modulation Generator B	Date
Type 4031	Unit	Sheet 1/3
Schlumberger	Functional Description	

**1.5 TX DC amplifier**

The TX DC amplifier (A11) supplies the signal from generator B to the DC OUT socket (Bu39) on the rear panel. If the output transformer (motherboard) is switched to 1:10, the TX DC amplifier is also switched to 1:10.

**1.6 Signal path to connector St64/23a**

The output signal is applied from generator B to connector St64/23a via A17, A10, A13 and output switch D22.

Ref.No. 208 032 F	Sub Modulation Generator B Unit	Date
Type 4031		Sheet 2/3
Schlumberger	Functional Description	

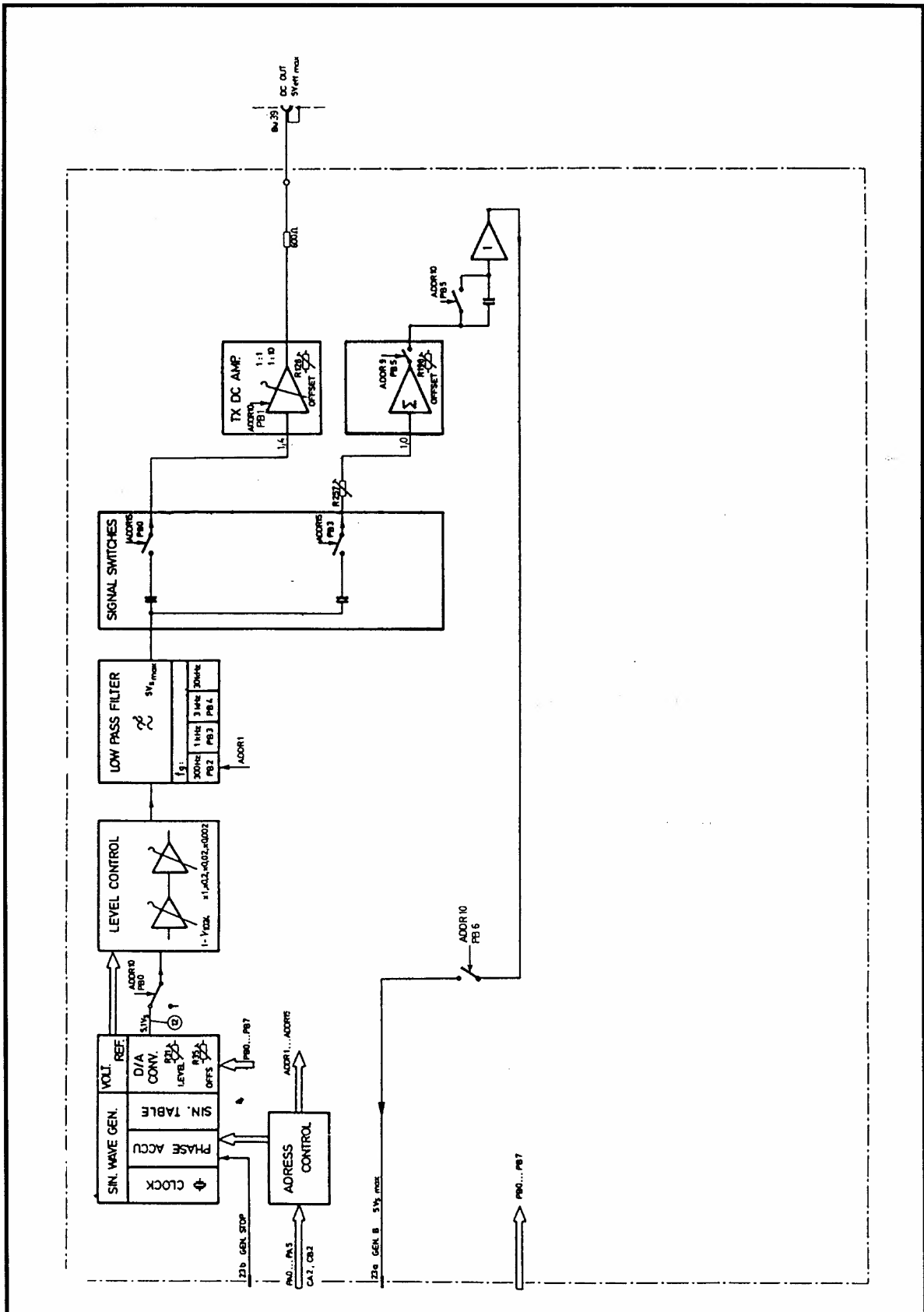

Ref. No. 208 032 F  
 Type 4031

Sub Modulation Generator B  
 Unit

Date  
 Sheet 3/3



Schlumberger		Adjustment and Test Procedure										Sheet	
Necessary Equipment	Measuring Procedure	Measuring Point	Frequency	Adjustment	Set Value	Actual Value	Issue	Alteration No.	Date	Name	Ref. No.	Sub Unit	Sheet
							Alteration No.	Date	Name	Type			
Oscilloscope HP audio analyzer DVM 7150 or better <u>Frequency counter</u>	<u>Check oscillator and frequency divider</u> 4031 setting: Mod. frequ. 16.384 kHz/5 V <sub>rms</sub>  Jumper set 1-2 Mod. frequ. 1 kHz  <u>D/A converter</u> 4031 setting: Mod. frequ. 16.384 kHz/5 V <sub>rms</sub> Check quantized sine wave for voltage spikes and dips  <u>Offset adjustment</u> 4031 setting: Mod. frequ. 16.384 kHz/5 V Jumper set 2-3	10			2.097152 MHz ±84 Hz						208 032 A	Modulation Generator B	1/3
		11 30			524.288 kHz ±21 Hz 52.429 kHz ±2.1 Hz								
DVM		12			0 mV ±1 mV						DC		

Necessary Equipment	Measuring Procedure	Measuring Point	Frequency	Adjustment	Set Value	Actual Value	Sheet							
							Issue	Alteration No.	Date	Sub Unit	Modulation Generator B	Sheet		
DVM	<u>Amplitude adjustment Generator B</u> 4031 setting: Jumper set 1-2 Mod. frequ. 1 kHz/5 V Mod. frequ. 1 kHz/0.1 V  <u>Check of amplitude setting</u> 4031 setting: Mod. frequ. 1 kHz/1 V Mod. frequ. 1 kHz/0.5 V Mod. frequ. 1 kHz/100 mV Mod. frequ. 1 kHz/10 mV  <u>Offset adjustment</u> 4031 setting: Mod. frequ. 1 kHz/10 mV Mod. off  <u>Adjustment generator B</u> 4031 setting: Generator B 1 kHz/5 V Modulation generator A must be connected or St64/23a loaded with 6.8 kΩ.	Bu29 Bu29  Bu29 Bu29 Bu29 Bu29  Bu29  St64/23a	1 kHz 1 kHz  1 kHz 1 kHz 1 kHz 1 kHz  DC  1 kHz	R31          R128   R257	5 V ±5 mV 0.1 V ±1 mV  1 V ±10 mV 0.5 V ±5 mV 100 mV ±1 mV 10 mV ±0.2 mV  0 mV ±1 mV  5 V ±15 mV									
							Ref. No.	208 032 A						
							Type	STABLOCK 4031						

Necessary Equipment	Measuring Procedure	Measuring Point	Frequency	Adjustment	Set Value	Actual Value	Issue	Alteration No.	Date	Name	Issue	Alteration No.	Date	Name	Ref. No.	Sub Unit	Sheet	
	<p>Frequency-response measurements</p> <p>DC OUT + TX mod.</p> <p>30 Hz</p> <p>50 Hz</p> <p>100 Hz</p> <p>200 Hz</p> <p>300 Hz</p> <p>1 kHz</p> <p>5 kHz</p> <p>10 kHz</p> <p>20 kHz</p> <p>30 kHz</p>	Bu29 & St64/17a			<p>5.0 V ±20 mV</p> <p>4.96 V ±20 mV</p> <p>4.85 V ±20 mV</p> <p>4.65 V ±20 mV</p>										208 032 A	Sub Modulation Generator B	3/3	
																STABILLOCK 4031		

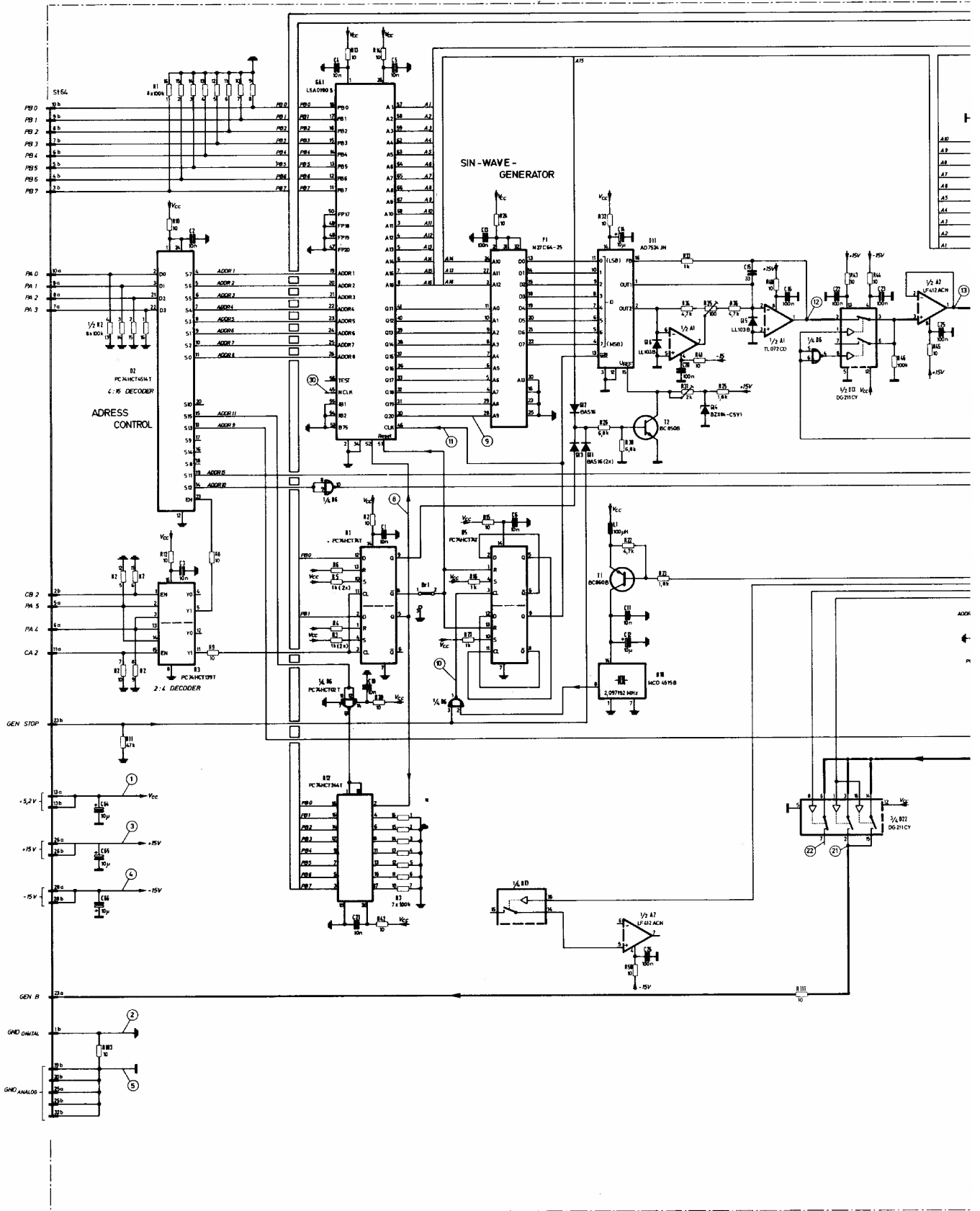

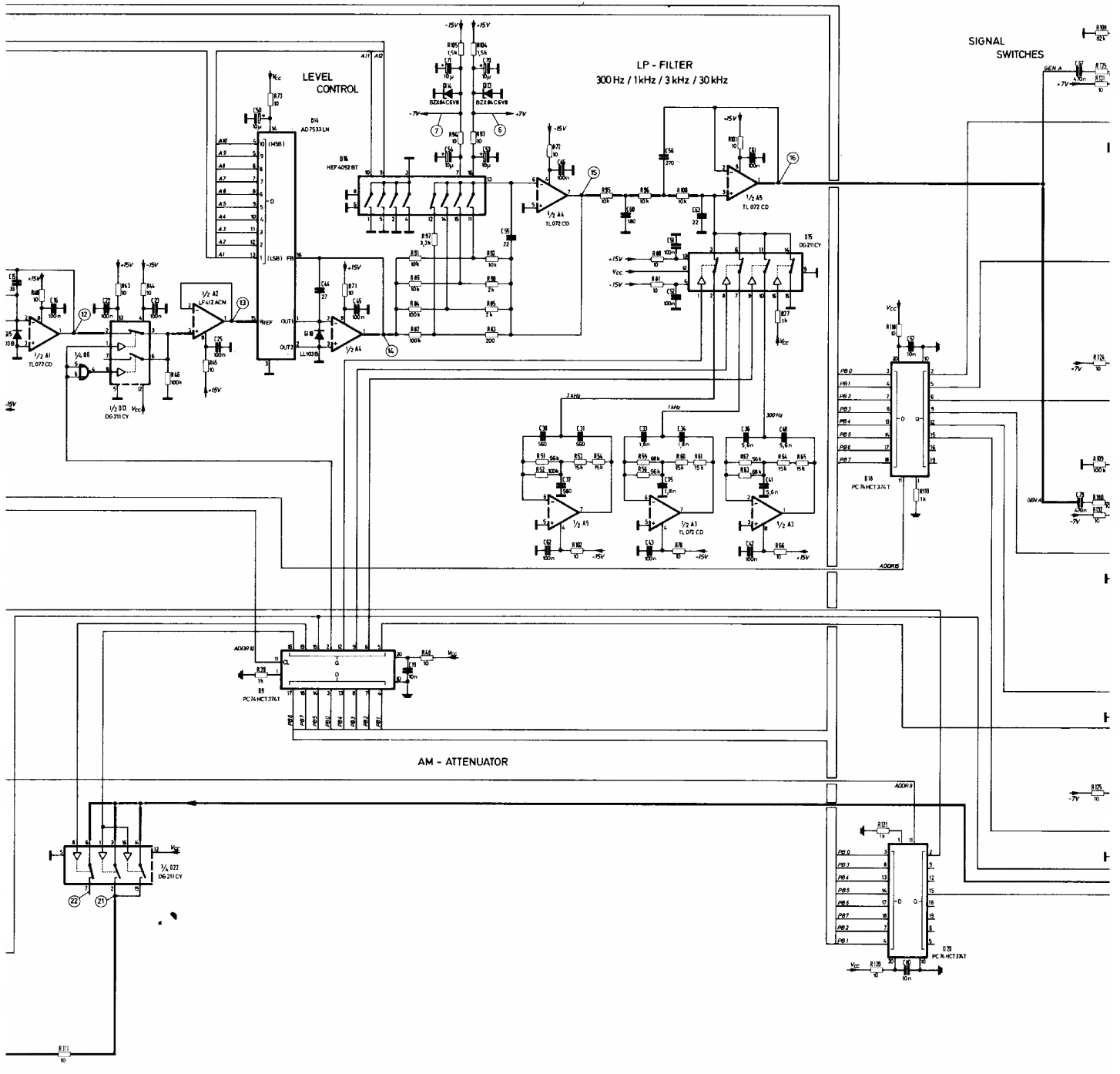

SIGNAL SWITCHES

LP - FILTER  
300 Hz / 1 kHz / 3 kHz / 30 kHz

LEVEL CONTROL

AM - ATTENUATOR

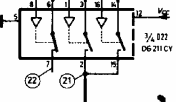
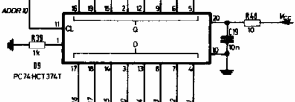
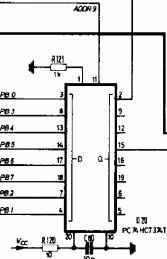

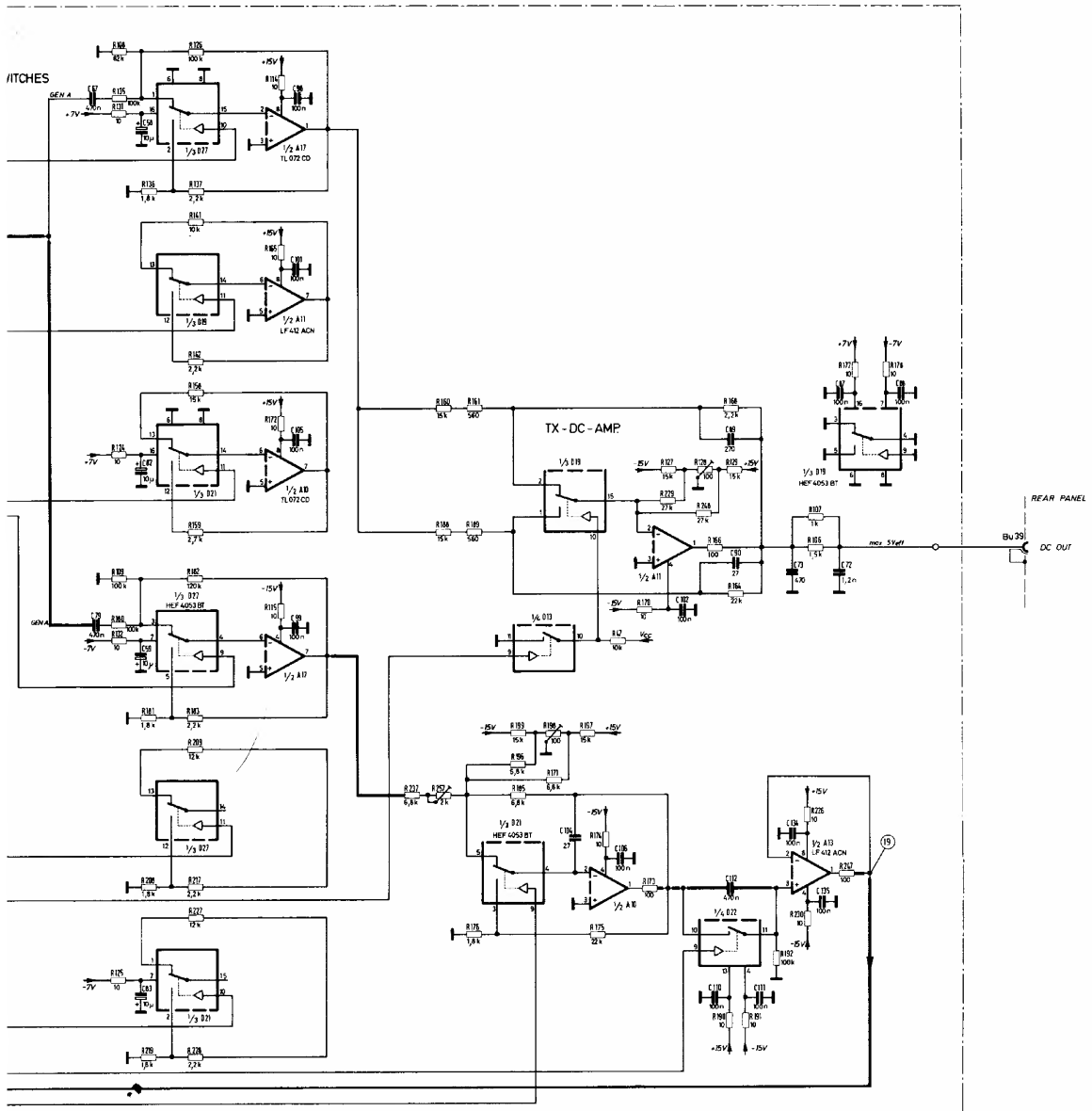

361 405  
461 405 04

A		S164		B	
TIMER OUT	1	GND			
CB1	2	CB2			
PA7	3	PB7			
PA6	4	PB6			
PA5	5	PB5			
PA4	6	PB4			
PA3	7	PB3			
PA2	8	PB2			
PA1	9	PB1			
PA0	10	PB0			
CA2	11	CA1			
ZF COUNT	12	TIMER CLK			
+5V (D)	13	-5V (D)			
GND	14	GND			
ZF GND	15	ZF			
RA FM	16	RA AN			
TRAFD	17	TRAFD GND			
EXT MOD	18	TX OFFS			
GND	19	GND			
GND	20	GND			
DC OPT	21	TRAFD 1 10			
DEMAND OUT	22	AF OPT			
GEN 2	23	GEN STOP			
RX MOD	24	TX PWR			
GND	25	GND			
+15V	26	+15V			
TX DEMOD	27	ANALYS CONTR			
-15V	28	-15V			
AF SUM	29	AF MONITOR			
+5V (ANA)	30	+5V (ANA)			
AF COUNT	31	GND			
8 MHz	32	GND			

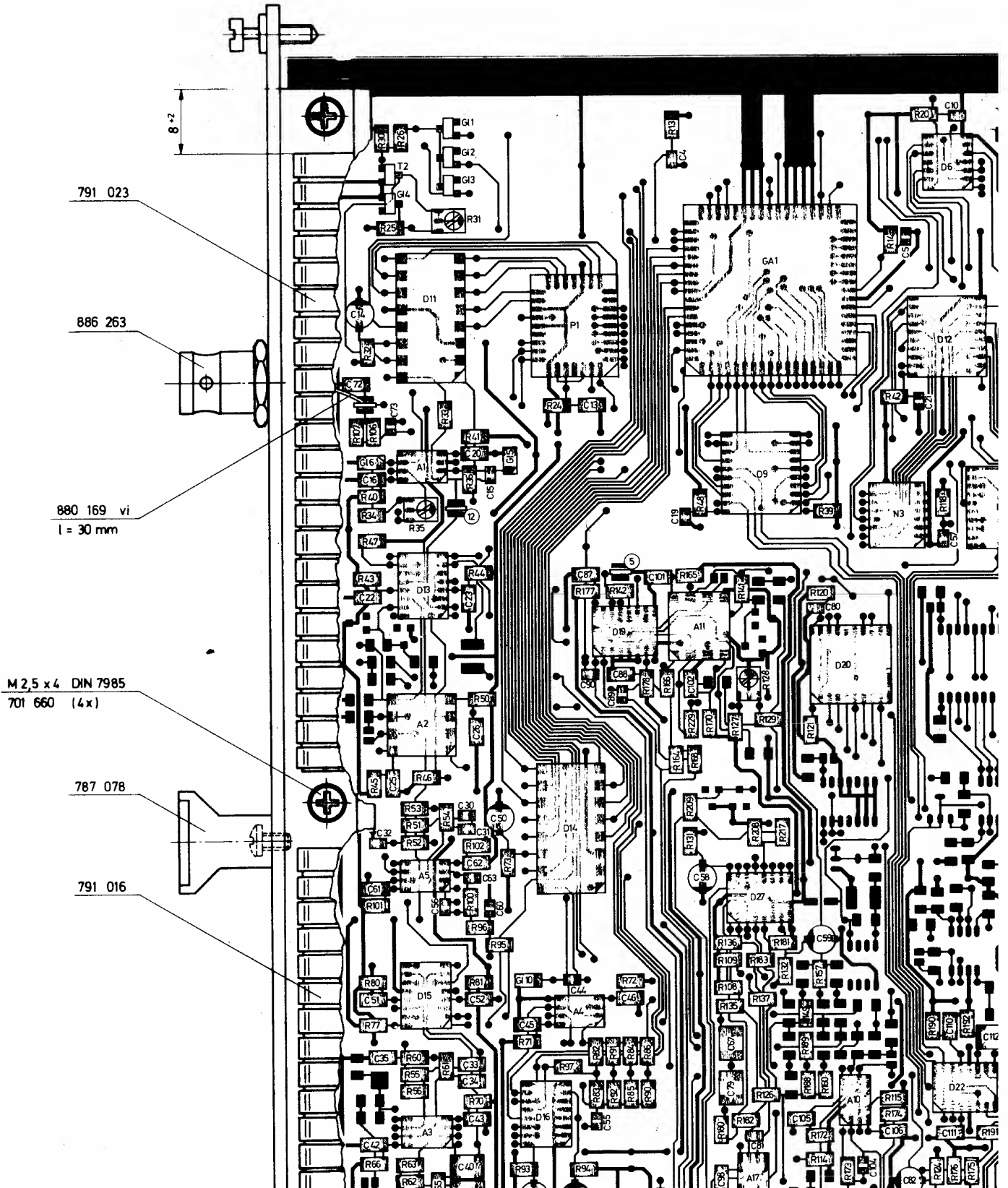

791 023

886 263

880 169 vi  
l = 30 mm

M 2,5 x 4 DIN 7985  
701 660 (4x)

787 078

791 016

8 x 2

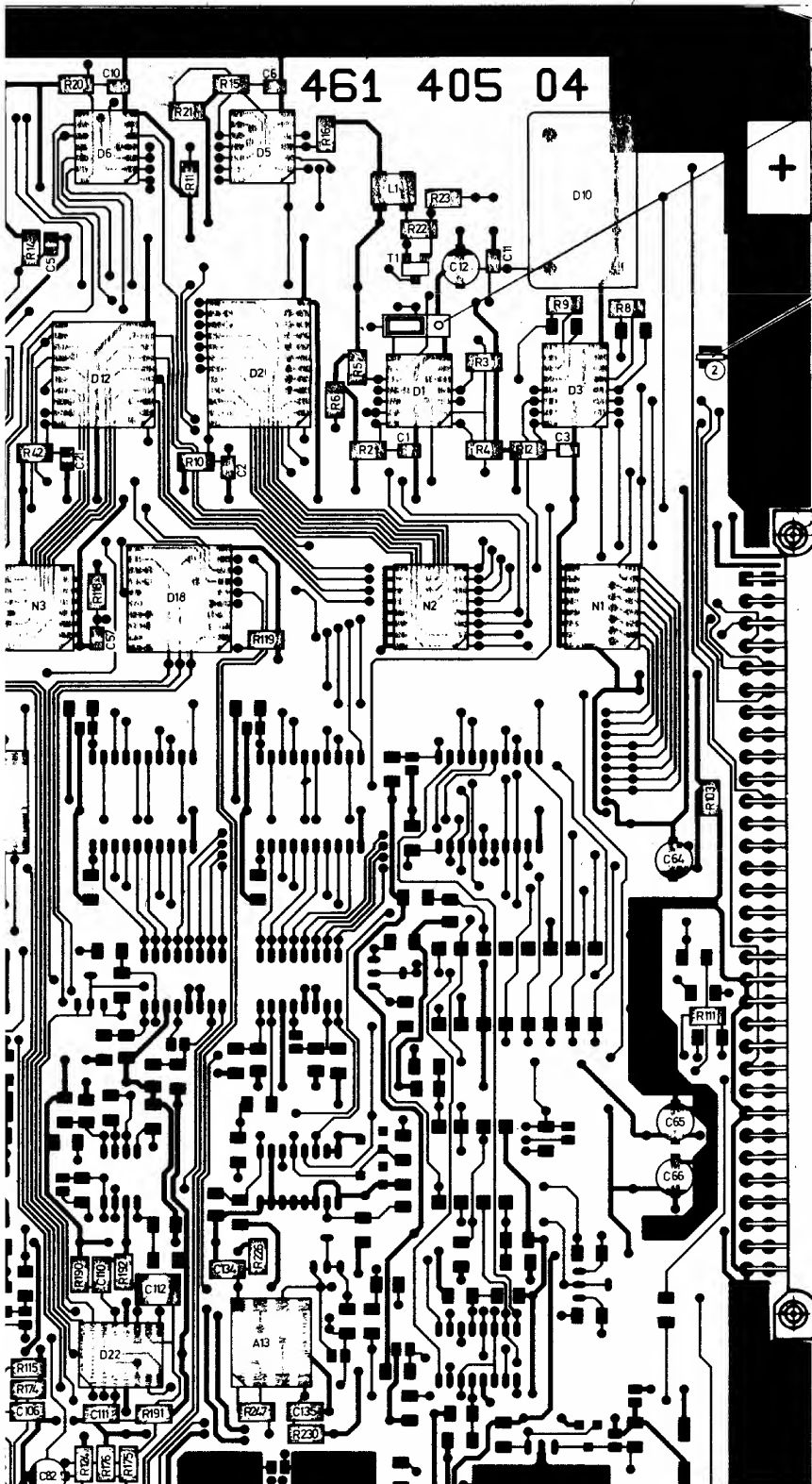

884 180  
884 182

786 009 (4x)

A 2,5 x 0,3 x 9 DIN 7340  
708 329 (2x)

884 500  
mit Schutzkappe 884 590 abgedeckt



Reflow gelötet  
hierzu Bauteilklebmaske 461 405 04



704 035 eingepreßt  
701 021

Bu 39

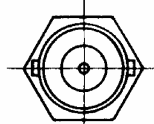

DC OUT

MIN 7340

884 590 abgedeckt

477 708

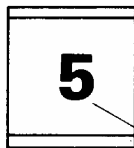

444 275

B 208 032

I  
H  
G  
F  
E  
D  
C

880 169 vi  
l = 30 mm

M 2,5 x 4 DIN 7985  
701 660 (4x)

787 078

791 016

10<sup>-2</sup>

Federklebeseite

Schaltplanpositionierung  $\triangle$  208 032 S / Sa

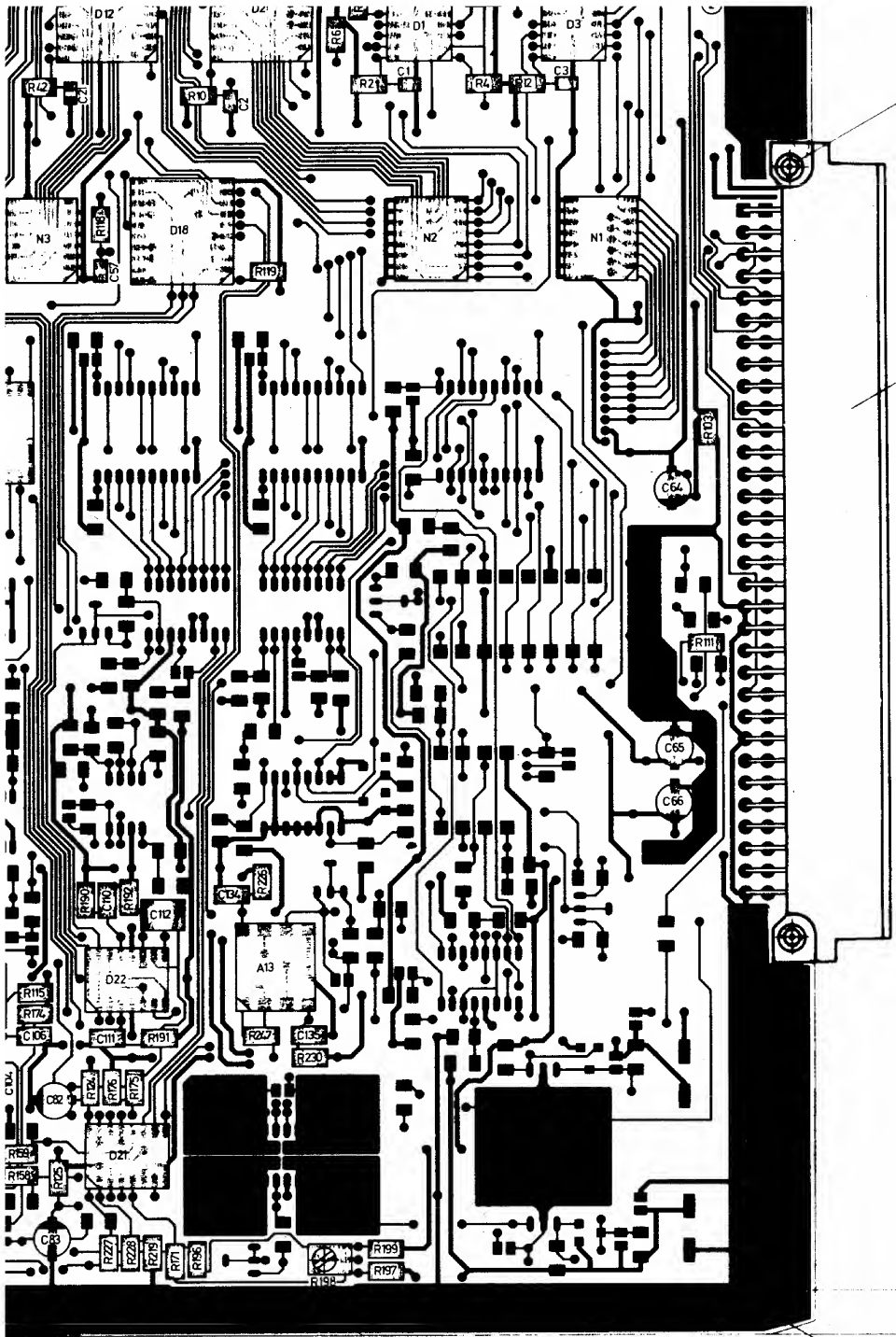

A 2,5 x 0,3 x 9 DIN 7340  
708 329 (2x)

884 500  
mit Schutzkappe 884 590 abgedeckt

beide Randstreifen  
vor dem Lötten abgedeckt





1	2	3	4	5	6	7	8
Pos REF NO	Wert VALUE	Bezeichnung Schlumberger PART NO	Hersteller MANUFACT	Pos REF. NO	Wert VALUE	Bezeichnung Schlumberger PART NO	Hersteller MANUFACT
				C 19	10 nF $\pm$ 10 % 50 V-	813 332	VITR
				C 20	100 nF $\pm$ 10 % 50 V-	813 375	VITR
				C 21	10 nF $\pm$ 10 % 50 V-	813 332	VITR
				C 22	100 nF $\pm$ 10 % 50 V-	813 375	VITR
				C 23	100 nF $\pm$ 10 % 50 V-	813 375	VITR
				C 25	100 nF $\pm$ 10 % 50 V-	813 375	VITR
				C 26	100 nF $\pm$ 10 % 50 V-	813 375	VITR
C 1	10 nF $\pm$ 10 % 50 V-	813 332	VITR				
C 2	10 nF $\pm$ 10 % 50 V-	813 332	VITR				
C 3	10 nF $\pm$ 10 % 50 V-	813 332	VITR	C 30	560 pF $\pm$ 5 % 50 V-	813 244	VITR
C 4	10 nF $\pm$ 10 % 50 V-	813 332	VITR	C 31	560 pF $\pm$ 5 % 50 V-	813 244	VITR
C 5	10 nF $\pm$ 10 % 50 V-	813 332	VITR	C 32	560 pF $\pm$ 5 % 50 V-	813 244	VITR
C 6	10 nF $\pm$ 10 % 50 V-	813 332	VITR	C 33	1,8 nF $\pm$ 5 % 50 V-	813 250	VITR
				C 34	1,8 nF $\pm$ 5 % 50 V-	813 250	VITR
				C 35	1,8 nF $\pm$ 5 % 50 V-	813 250	VITR
				C 36	5,6 nF $\pm$ 5 % 50 V-	813 256	VITR
C 10	10 nF $\pm$ 10 % 50 V-	813 332	VITR				
C 11	10 nF $\pm$ 10 % 50 V-	813 332	VITR				
C 12	10 $\mu$ F $\pm$ 20 % 16 V-	814 382	RÖD				
C 13	100 nF $\pm$ 10 % 50 V-	813 375	VITR	C 40	5,6 nF $\pm$ 5 % 50 V-	813 256	VITR
C 14	10 $\mu$ F $\pm$ 20 % 16 V-	814 382	RÖD	C 41	5,6 nF $\pm$ 5 % 50 V-	813 256	VITR
C 15	33 pF $\pm$ 5 % 50 V-	813 229	VITR	C 42	100 nF $\pm$ 10 % 50 V-	813 375	VITR
C 16	100 nF $\pm$ 10 % 50 V-	813 375	VITR	C 43	100 nF $\pm$ 10 % 50 V-	813 375	VITR
				C 44	27 pF $\pm$ 5 % 50 V-	813 228	VITR
				C 45	100 nF $\pm$ 10 % 50 V-	813 375	VITR
07				Schaltteilliste EL. PARTS LIST			Liste besteht LIST CONSISTS aus OF 10 Blatt SHEETS
06							
05				Benennung DESCRIPTION Mod. Generator B			Blatt Nr SHEET NO
04							
03				Bezeichnung Schlumberger PART NO 208 032 Sa			2
02							
01				Hierzu Schaltplan SEE CIRCUIT DIAGR- 208 032 S			
Ausgabe ISSUE		And-Mittig Nr	Tag DATE	Name NAME	Geschr bearb gedr		
					30.10.86 Morasch		
					Gerät: 4031		

Diese Zeichnung ist unser Eigentum. Vervielfältigung, unbefugte Verwertung, Mitteilung an andere ist strafbar und schadenersatzpflichtig.

1	2	3	4	5	6	7	8
Pos REF. NO	Wert VALUE	Bezeichnung Schlumberger PART. NO.	Hersteller MANUFACT	Pos. REF NO	Wert VALUE	Bezeichnung Schlumberger PART. NO.	Hersteller MANUFACT
C 46	100 nF $\pm$ 10 % 50 V-	813 375	VITR	C 73	470 pF $\pm$ 5 % 50 V-	813 243	VITR
C 50	10 $\mu$ F $\pm$ 20 % 16 V-	814 382	RÖD				
C 51	100 nF $\pm$ 10 % 50 V-	813 375	VITR				
C 52	100 nF $\pm$ 10 % 50 V-	813 375	VITR	C 79	470 nF $\pm$ 10 % 50 V-	813 383	VITR
C 53	10 $\mu$ F $\pm$ 20 % 16 V-	814 382	RÖD	C 80	10 nF $\pm$ 10 % 50 V-	813 332	VITR
C 54	10 $\mu$ F $\pm$ 20 % 16 V-	814 382	RÖD				
C 55	22 pF $\pm$ 5 % 50 V-	813 227	VITR	C 82	10 $\mu$ F $\pm$ 20 % 16 V-	814 382	RÖD
C 56	270 pF $\pm$ 5 % 50 V-	813 240	VITR	C 83	10 $\mu$ F $\pm$ 20 % 16 V-	814 382	RÖD
C 57	10 nF $\pm$ 10 % 50 V-	813 332	VITR				
C 58	10 $\mu$ F $\pm$ 20 % 16 V-	814 382	RÖD				
C 59	10 $\mu$ F $\pm$ 20 % 16 V-	814 382	RÖD				
C 60	180 pF $\pm$ 5 % 50 V-	813 238	VITR	C 87	100 nF $\pm$ 10 % 50 V-	813 375	VITR
C 61	100 nF $\pm$ 10 % 50 V-	813 375	VITR	C 88	100 nF $\pm$ 10 % 50 V-	813 375	VITR
C 62	100 nF $\pm$ 10 % 50 V-	813 375	VITR	C 89	270 pF $\pm$ 5 % 50 V-	813 240	VITR
C 63	22 pF $\pm$ 5 % 50 V-	813 227	VITR	C 90	27 pF $\pm$ 5 % 50 V-	813 228	VITR
C 64	10 $\mu$ F $\pm$ 20 % 16 V-	814 382	RÖD				
C 65	10 $\mu$ F $\pm$ 20 % 16 V-	814 382	RÖD				
C 66	10 $\mu$ F $\pm$ 20 % 16 V-	814 382	RÖD				
C 67	470 nF $\pm$ 10 % 50 V-	813 383	VITR				
C 70	10 $\mu$ F $\pm$ 20 % 16 V-	814 382	RÖD				
C 71	10 $\mu$ F $\pm$ 20 % 16 V-	814 382	RÖD	C 98	100 nF $\pm$ 10 % 50 V-	813 375	VITR
C 72	1,2 nF $\pm$ 5 % 50 V-	813 248	VITR	C 99	100 nF $\pm$ 10 % 50 V-	813 375	VITR
07				Schalteilliste EL. PARTS LIST			Liste besteht LIST CONSISTS aus OF 10 Blatt SHEETS
06			Schlumberger Meßgeräte GmbH Ingolstädter Straße 67a 8000 München 46				
05				Benennung DESCRIPTION Mod. Generator B			Blatt Nr SHEET NO 3
04				Bezeichnung Schlumberger PART NO 208 032 Sa			
03				Hierzu Schaltplan SEE CIRCUIT DIAGRAM 208 032 S			
02				Gerät: 4031			
01							
-	7088.175	26.11.97	ke	geschr	16.11.97	Dietrich	
Ausgabe ISSUE	And-Mittg. Nr MODIFIC NO	Tag DATE	Name NAME	bearb gpdf			

Diese Zeichnung ist unser Eigentum. Vervielfältigung, unbefugte Verwertung, Mitteilung an andere ist strafbar und schadenersatzpflichtig





1	2	3	4	5	6	7	8	
Pos REF NO	Wert VALUE	Bezeichnung Schlumberger PART NO	Hersteller MANUFACT	Pos REF NO	Wert VALUE	Bezeichnung Schlumberger PART NO	Hersteller MANUFACT	
D 1	PC 74 HCT 74 T	834 433	VAL					
D 2	PC 74 HCT 4514 T	834 443	VAL					
D 3	PC 74 HCT 139 T	834 435	VAL					
D 5	PC 74 HCT 74 T	834 433	VAL					
D 6	PC 74 HCT 02 T	334 431	VAL					
D 9	PC 74 HCT 374 T	834 437	VAL					
D 10	MCO 4515 B	853 301	ELEC					
D 11	AD 7524 JN	834 131	DEV	GA 1	L 5 A 0190 S	835 100	LSI	
D 12	PC 74 HCT 244 T	834 436	VAL					
D 13	DG 211 CY	834 471	SILI					
D 14	AD 7533 LN	834 124	ANA					
D 15	DG 211 CY	834 471	SILI					
D 16	HEF 4052 BT	834 441	VAL	GI 1	BAS 16	830 552	VAL	
				GI 2	BAS 16	830 552	VAL	
D 18	PC 74 HCT 374 T	834 437	VAL	GI 3	BAS 16	830 552	VAL	
D 19	HEF 4053 BT	834 442	VAL	GI 4	BZX 84 C 5 V 1	830 492	VAL	
D 20	PC 74 HCT 374 T	834 437	VAL	GI 5	LL 103 B	830 517	ITT	
D 21	HEF 4053 BT	834 442	VAL	GI 6	LL 103 B	830 517	ITT	
D 22	DG 211 CY	834 471	SILI					
				GI 10	LL 103 B	830 517	ITT	
D 27	HEF 4053 BT	834 442	VAL					
07				Schlumberger Meßgeräte GmbH Ingolstädter Straße 67 a 8000 München 46			Schaltteilliste EL. PARTS LIST Benennung DESCRIPTION Mod. Generator B	Liste besteht LIST CONSISTS aus OF 10 Blatt SHEETS
06								
05								
04								
03								
02								
01								
-	7088.175	26.11.87	KG	geschr	31.10.86	Morasch	Bezeichnung Schlumberger PART NO 208 032 Sa	Blatt Nr SHEET NO 5
Aus- gabe ISSUE	And-Mittig Nr MODIFIC NO	Tag DATE	Name NAME	bearb gepr			Hierzu Schaltplan SEE CIRCUIT DIAGRAM 208 032 S Gerät: 4031	

Diese Zeichnung ist unser Eigentum. Vervielfältigung, unbefugte Verwertung, Mitteilung an andere ist strafbar und schadenersatzpflichtig



1	2	3	4	5	6	7	8
Pos REF NO	Wert VALUE	Bezeichnung Schlumberger PART. NO.	Hersteller MANUFACT	Pos. REF. NO.	Wert VALUE	Bezeichnung Schlumberger PART NO	Hersteller MANUFACT
				R 45	10 Ω ± 1 %	802 713	BEY
				R 46	100 kΩ ± 1 %	802 761	BEY
R 20	10 Ω ± 1 %	802 713	BEY	R 47	10 kΩ ± 1 %	802 749	BEY
R 21	1 kΩ ± 1 %	802 737	BEY	R 48	10 Ω ± 1 %	802 713	BEY
R 22	4,7 kΩ ± 1 %	802 745	BEY				
R 23	1,8 kΩ ± 1 %	802 740	BEY	R 50	10 Ω ± 1 %	802 713	BEY
R 24	10 Ω ± 1 %	802 713	BEY	R 51	56 kΩ ± 1 %	802 758	BEY
R 25	1,8 kΩ ± 1 %	802 740	BEY	R 52	100 kΩ ± 1 %	802 761	BEY
R 26	6,8 kΩ ± 1 %	802 747	BEY	R 53	15 kΩ ± 1 %	802 751	BEY
				R 54	15 kΩ ± 1 %	802 751	BEY
				R 55	68 kΩ ± 1 %	802 759	BEY
				R 56	56 kΩ ± 1 %	802 758	BEY
R 30	6,8 kΩ ± 1 %	802 747	BEY				
R 31	2 kΩ ± 25 %	807 738	BOUR				
R 32	10 Ω ± 1 %	802 713	BEY				
R 33	1 kΩ ± 1 %	802 737	BEY	R 60	15 kΩ ± 1 %	802 751	BEY
R 34	4,7 kΩ ± 1 %	802 745	BEY	R 61	15 kΩ ± 1 %	802 751	BEY
R 35	100 Ω ± 25 %	807 734	BOU	R 62	56 kΩ ± 1 %	802 758	BEY
R 36	4,7 kΩ ± 1 %	802 745	BEY	R 63	68 kΩ ± 1 %	802 759	BEY
				R 64	15 kΩ ± 1 %	802 751	BEY
				R 65	15 kΩ ± 1 %	802 751	BEY
R 39	1 kΩ ± 1 %	802 737	BEY	R 66	10 Ω ± 1 %	802 713	BEY
R 40	10 Ω ± 1 %	802 713	BEY				
R 41	10 Ω ± 1 %	802 713	BEY				
R 42	10 Ω ± 1 %	802 713	BEY				
R 43	10 Ω ± 1 %	802 713	BEY	R 70	10 Ω ± 1 %	802 713	BEY
R 44	10 Ω ± 1 %	802 713	BEY	R 71	10 Ω ± 1 %	802 713	BEY
07				<b>Schalteilliste</b> EL. PARTS LIST			Liste besteht LIST CONSISTS aus OF 10 Blatt SHEETS
06							
05				Ingolstädter Straße 67 a 8000 München 46			Blatt Nr SHEET NO 7
04				Bezeichnung DESCRIPTION Mod. Generator B			
03				Bezeichnung Schlumberger PART NO 208 032 Sa			Blatt Nr SHEET NO 7
02				Hierzu Schaltplan SEE CIRCUIT DIAGRAM 208 032 S			
01				Gerät: 4031			
Ausgabe ISSUE		Änd.-Mittig Nr MODIFIC. NO	Tag DATE	Name NAME			
			geschr 31.10.86	Morasch			
			bearb	<i>LM</i>			
			gepr				

Diese Zeichnung ist unser Eigentum. Vervielfältigung, unbefugte Verwertung, Mitteilung an andere ist strafbar und schadenersatzpflichtig.

1	2	3	4	5	6	7	8
Pos REF NO	Wert VALUE	Bezeichnung Schlumberger PART NO.	Hersteller MANUFACT	Pos REF NO	Wert VALUE	Bezeichnung Schlumberger PART NO	Hersteller MANUFACT
R 72	10 Ω ± 1 %	802 713	BEY				
R 73	10 Ω ± 1 %	802 713	BEY	R 100	10 kΩ ± 1 %	802 749	BEY
				R 101	10 Ω ± 1 %	802 713	BEY
				R 102	10 Ω ± 1 %	802 713	BEY
				R 103	10 Ω ± 1 %	802 713	BEY
R 77	1 kΩ ± 1 %	802 737	BEY	R 104	1,5 kΩ ± 1 %	802 739	BEY
				R 105	1,5 kΩ ± 1 %	802 739	BEY
				R 106	1,5 kΩ ± 1 %	802 739	BEY
R 80	10 Ω ± 1 %	802 713	BEY	R 107	1 kΩ ± 1 %	802 737	BEY
R 81	10 Ω ± 1 %	802 713	BEY	R 108	82 kΩ ± 1 %	802 760	BEY
R 82	100 kΩ ± 0,25 %	802 861	BEY	R 109	100 kΩ ± 1 %	802 761	BEY
R 83	200 Ω ± 0,25 %	802 886	BEY				
R 84	100 kΩ ± 0,25 %	802 861	BEY	R 111	10 Ω ± 1 %	802 713	BEY
R 85	2 kΩ ± 0,25 %	802 887	BEY				
R 86	10 kΩ ± 0,25 %	802 849	BEY				
				R 114	10 Ω ± 1 %	802 713	BEY
				R 115	10 Ω ± 1 %	802 713	BEY
R 90	2 kΩ ± 0,25 %	802 887	BEY				
R 91	10 kΩ ± 0,25 %	802 849	BEY	R 118	10 Ω ± 1 %	802 713	BEY
R 92	10 kΩ ± 0,25 %	802 849	BEY	R 119	1 kΩ ± 1 %	802 737	BEY
R 93	10 Ω ± 1 %	802 713	BEY	R 120	10 Ω ± 1 %	802 713	BEY
R 94	10 Ω ± 1 %	802 713	BEY	R 121	1 kΩ ± 1 %	802 737	BEY
R 95	10 kΩ ± 1 %	802 749	BEY				
R 96	10 kΩ ± 1 %	802 749	BEY				
R 97	3,3 kΩ ± 1 %	802 743	BEY	R 124	10 Ω ± 1 %	802 713	BEY
				R 125	10 Ω ± 1 %	802 713	BEY

07				Schlumberger Meßgeräte GmbH Ingolstädter Straße 67a 8000 München 46		Schaltteilliste EL. PARTS LIST Benennung DESCRIPTION Mod. Generator B		Liste besteht LIST CONSISTS aus OF 10 Blatt SHEETS
06								
05								
04								
03								
02								
01								
				geschr	31.10.86	Morasch	Bezeichnung Schlumberger PART NO	208 032 Sa
				bearb			Hierzu Schaltplan SEE CIRCUIT DIAGRAM	208 032 S
Aus- gabe ISSUE	Änd.-Mitgl. Nr MODIFIC. NO	Tag DATE	Name NAME	gepr			Gerät: 4031	Blatt Nr SHEET NO 8

Diese Zeichnung ist unser Eigentum. Vervielfältigung, unbefugte Verwertung, Mitteilung an andere ist strafbar und schadenersatzpflichtig.

1	2	3	4	5	6	7	8
Pos. REF. NO	Wert VALUE	Bezeichnung Schlumberger PART. NO.	Hersteller MANUFACT	Pos. REF. NO.	Wert VALUE	Bezeichnung Schlumberger PART. NO.	Hersteller MANUFACT
R 126	100 kΩ ± 1 %	802 761	BEY	R 158	15 kΩ ± 1 %	802 751	BEY
R 127	15 kΩ ± 1 %	802 751	BEY	R 159	2,7 kΩ ± 1 %	802 742	BEY
R 128	100 Ω ± 25 %	807 734	BOUR	R 160	15 kΩ ± 0,25 %	802 851	BEY
R 129	15 kΩ ± 1 %	802 751	BEY	R 161	560 Ω ± 1 %	802 734	BEY
R 131	10 Ω ± 1 %	802 713	BEY				
R 132	10 Ω ± 1 %	802 713	BEY	R 164	22 kΩ ± 0,25 %	802 853	BEY
				R 165	10 Ω ± 1 %	802 713	BEY
				R 166	100 Ω ± 1 %	802 725	BEY
R 135	100 kΩ ± 1 %	802 761	BEY				
R 136	1,8 kΩ ± 1 %	802 740	BEY	R 168	2,2 kΩ ± 1 %	802 741	BEY
R 137	2,2 kΩ ± 1 %	802 741	BEY				
				R 170	10 Ω ± 1 %	802 713	BEY
				R 171	6,8 kΩ ± 1 %	802 747	BEY
				R 172	10 Ω ± 1 %	802 713	BEY
R 141	10 kΩ ± 1 %	802 749	BEY	R 173	100 Ω ± 1 %	802 725	BEY
R 142	2,2 kΩ ± 1 %	802 741	BEY	R 174	10 Ω ± 1 %	802 713	BEY
				R 175	22 kΩ ± 1 %	802 753	BEY
				R 176	1,8 kΩ ± 1 %	802 740	BEY
				R 177	10 Ω ± 1 %	802 713	BEY
				R 178	10 Ω ± 1 %	802 713	BEY
				R 180	100 kΩ ± 1 %	802 761	BEY
				R 181	1,8 kΩ ± 1 %	802 740	BEY
				R 182	120 kΩ ± 1 %	802 762	BEY
				R 183	2,2 kΩ ± 1 %	802 741	BEY

07				Schlumberger Meßgeräte GmbH Ingolstädter Straße 67 a 8000 München 46			Schaltteilliste EL. PARTS LIST Benennung DESCRIPTION Mod. Generator B		Liste besteht LIST CONSISTS aus OF 10 Blatt SHEETS
06									
05									
04									
03									
02				1987	Tag DATE	Name NAME	Bezeichnung Schlumberger PART. NO	208 032 Sa	Blatt Nr. SHEET NO 9
01				geschr.	16.11.87	Dietrich	Hierzu Schaltplan SEE CIRCUIT DIAGRAM	208 032 S	
-	7088.175	27.11.87	kg	bearb.			Gerät: 4031		
Aus- gabe ISSUE	And.-Mittg. Nr MODIFIC. NO	Tag DATE	Name NAME	gedr.					

Diese Zeichnung ist unser Eigentum. Vervielfältigung, unbefugte Verwertung, Mitteilung an andere ist strafbar und schadenersatzpflichtig

1	2	3	4	5	6	7	8
Pos REF NO	Wert VALUE	Bezeichnung Schlumberger PART. NO.	Hersteller MANUFACT	Pos REF. NO	Wert VALUE	Bezeichnung Schlumberger PART. NO	Hersteller MANUFACT
R 135	6,8 kΩ ± 1 %	802 747	BEY				
				R 219	1,8 kΩ ± 1 %	802 740	BEY
R 138	15 kΩ ± 0,25 %	802 851	BEY				
R 189	560 Ω ± 1 %	802 734	BEY	R 226	10 Ω ± 1 %	802 713	BEY
R 190	10 Ω ± 1 %	802 713	BEY	R 227	12 kΩ ± 1 %	802 750	BEY
R 191	10 Ω ± 1 %	802 713	BEY	R 228	2,2 kΩ ± 1 %	802 741	BEY
R 192	100 kΩ ± 1 %	802 761	BEY	R 229	27 kΩ ± 1 %	802 754	BEY
				R 230	10 Ω ± 1 %	802 713	BEY
R 196	6,8 kΩ ± 1 %	802 747	BEY	R 237	6,8 kΩ ± 1 %	802 747	BEY
R 197	15 kΩ ± 1 %	802 751	BEY				
R 198	100 Ω ± 25 %	807 734	BOUR	R 247	100 Ω ± 1 %	802 725	BEY
R 199	15 kΩ ± 1 %	802 751	BEY	R 248	27 kΩ ± 1 %	802 754	BEY
				R 257	2 kΩ ± 25 %	807 738	BOU
R 208	1,8 kΩ ± 1 %	802 740	BEY				
R 209	12 kΩ ± 1 %	802 750	BEY				
				St 64	C42 334-A191-A521	884 500	SIE
				T 1	BC 860 B	832 285	SIE
				T 2	BC 850 B	832 284	SIE
R 217	2,2 kΩ ± 1 %	802 741	BEY				

07				Schlumberger Meßgeräte GmbH Ingolstädter Straße 67 a 8000 München 46			Schaltteilliste EL. PARTS LIST Benennung DESCRIPTION Mod. Generator B		Liste besteht LIST CONSISTS aus OF 10 Blatt SHEETS
06									
05									
04									
03									
02				1987	Tag DATE	Name NAME	Bezeichnung Schlumberger PART NO	208 032 Sa	Blatt Nr. SHEET NO 10
01				geschr.	16.11.87	Dietrich	Hierzu Schaltplan SEE CIRCUIT DIAGRAM	208 032 S	
-	7088.175	27.11.87	EG	bearb.		Lo	Gerät:	4031	
Ausgabe ISSUE	Änd.-Mittig. Nr MODIFIC. NO.	Tag DATE	Name NAME	gepr.					

Diese Zeichnung ist unser Eigentum. Vervielfältigung, unbefugte Verwertung, Mitteilung an andere ist strafbar und schadenersatzpflichtig

**AF detector (VOLTM)**

**Circuitry on front panel:**

Input Bu21 of the AF detector is balanced, but one pole can be led to chassis ground. The input impedance is 100 k $\Omega$  and can be reduced to 600  $\Omega$ . The following balanced impedance transformer A2 is directly on the input socket behind the front panel to keep interference minimal. This is followed by switch D1, which connects either the voltmeter input or the output signal of the modulation generator to the digitally set preamplifier A4. This relates the signal to chassis ground and can be varied in gain between x1, x10 and x100.

**Circuitry on AF detector:**

Via switch D20 and the main amplifier A200, which can be switched in gain between x1, x2, x5, x10, x20 and x50, the signal is applied by way of optionally interconnected filters (external filter, CCITT) to the AF frequency counter A290, the monitoring amplifier A70, to the oscilloscope and to RMS converter A332. From here the signal is taken via multiplexer D140 to the microprocessorized data-acquisition system on the slave computer for processing. For distortion and SINAD measurement the signal is additionally applied via the 1-kHz notch filter or the external notch filter to a second RMS converter A331.

Autoranging is performed by means of the auxiliary peak detector A240/A270.

Ref.No. 209 031 F	Sub AF Detector	Date
Type 4031	Unit	Sheet 1/11
Schlumberger	Functional Description	

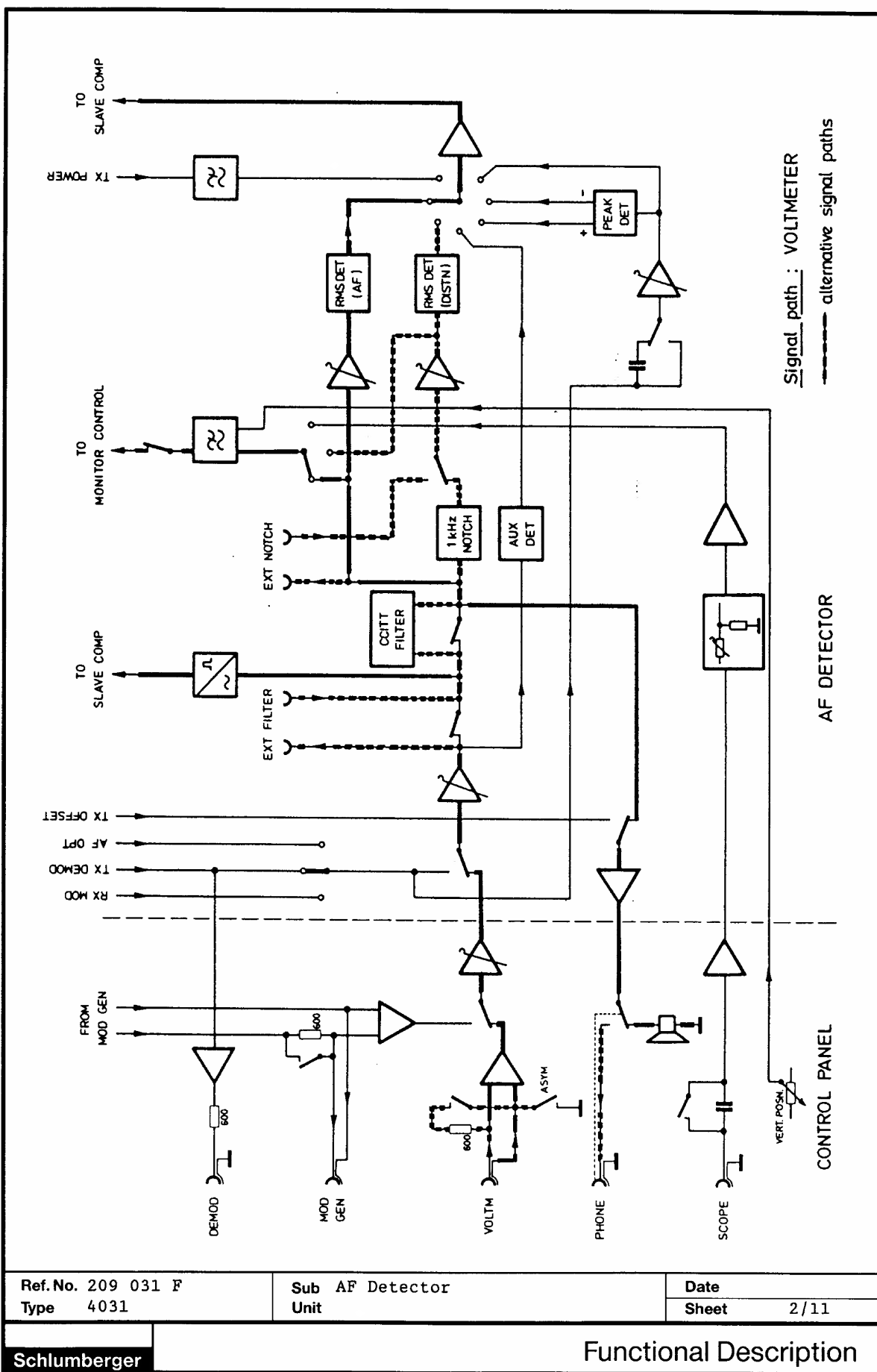

Ref.No. 209 031 F  
 Type 4031

Sub AF Detector  
 Unit

Date  
 Sheet 2/11

Schlumberger

Functional Description



**MOD generator (GEN)**

Circuitry on front panel:

The voltage for modulating a transmitter is measured directly on the MOD GEN socket, ie balanced as the sum of the voltage from modulation generator A, an optional generator and possibly an external modulation voltage. The signal is processed, as in the AF detector, by a balanced impedance transformer A1.

Onwards from the following switch D1, the signal flow via the filters and RMS detector is identical to that in the AF detector.

Ref.No. 209 031 F	Sub AF Detector	Date
Type 4031	Unit	Sheet 3/11
Schlumberger	Functional Description	

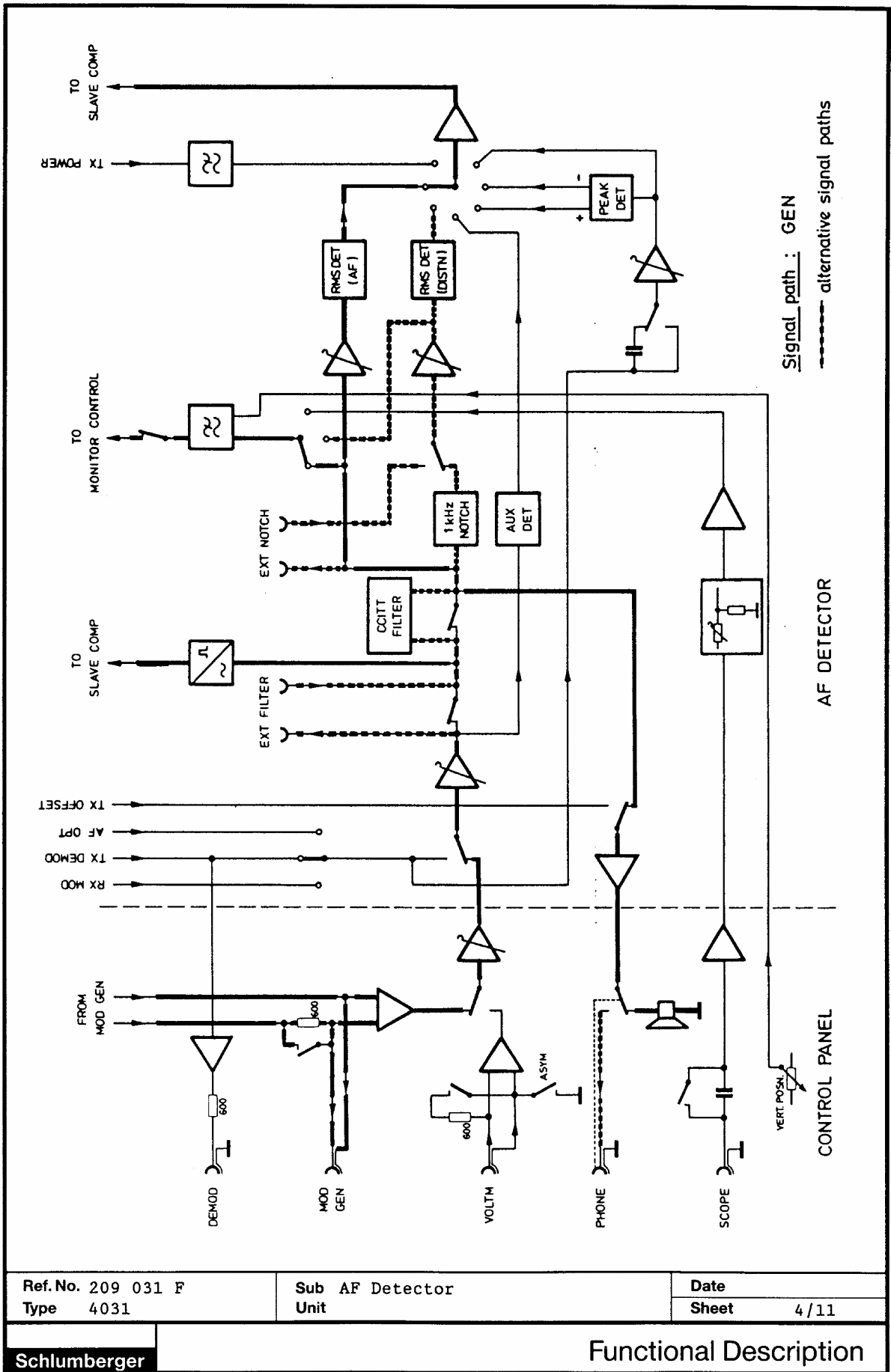

Ref. No. 209 031 F  
 Type 4031

Sub AF Detector  
 Unit

Date  
 Sheet 4/11

Schlumberger

Functional Description

TX signal path

From the IF demodulators the AF signal is applied via signal multiplexer D20 to the switchable main AF amplifier A200. From there the signal flow via the filters and RMS detector is identical to that in the AF detector.

Parallel to this there is an impedance transformer that amplifies by a factor of 5 if required. Depending on the mode of measurement, the signal is applied AC-coupled or DC-coupled to the clocked, peak-responding rectifier. This supplies the negative and positive peak values separately via multiplexer D140 to the data-acquisition system on the slave computer.

Ref.No. 209 031 F	Sub AF Detector	Date
Type 4031	Unit	Sheet 5/11
Schlumberger	Functional Description	

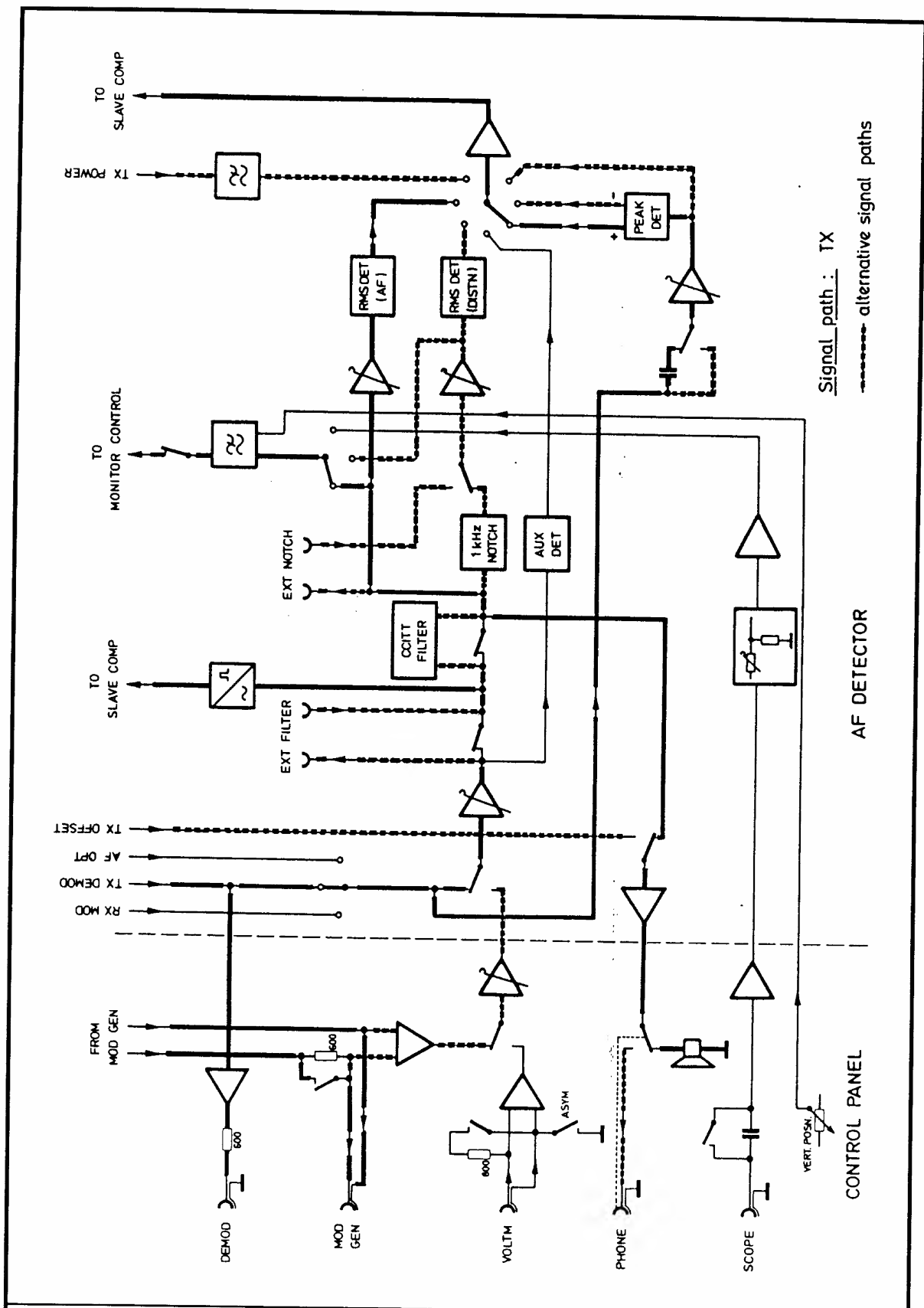

Ref. No. 209 031 F  
 Type 4031

Sub AF Detector  
 Unit

Date  
 Sheet 6/11

Schlumberger

Functional Description

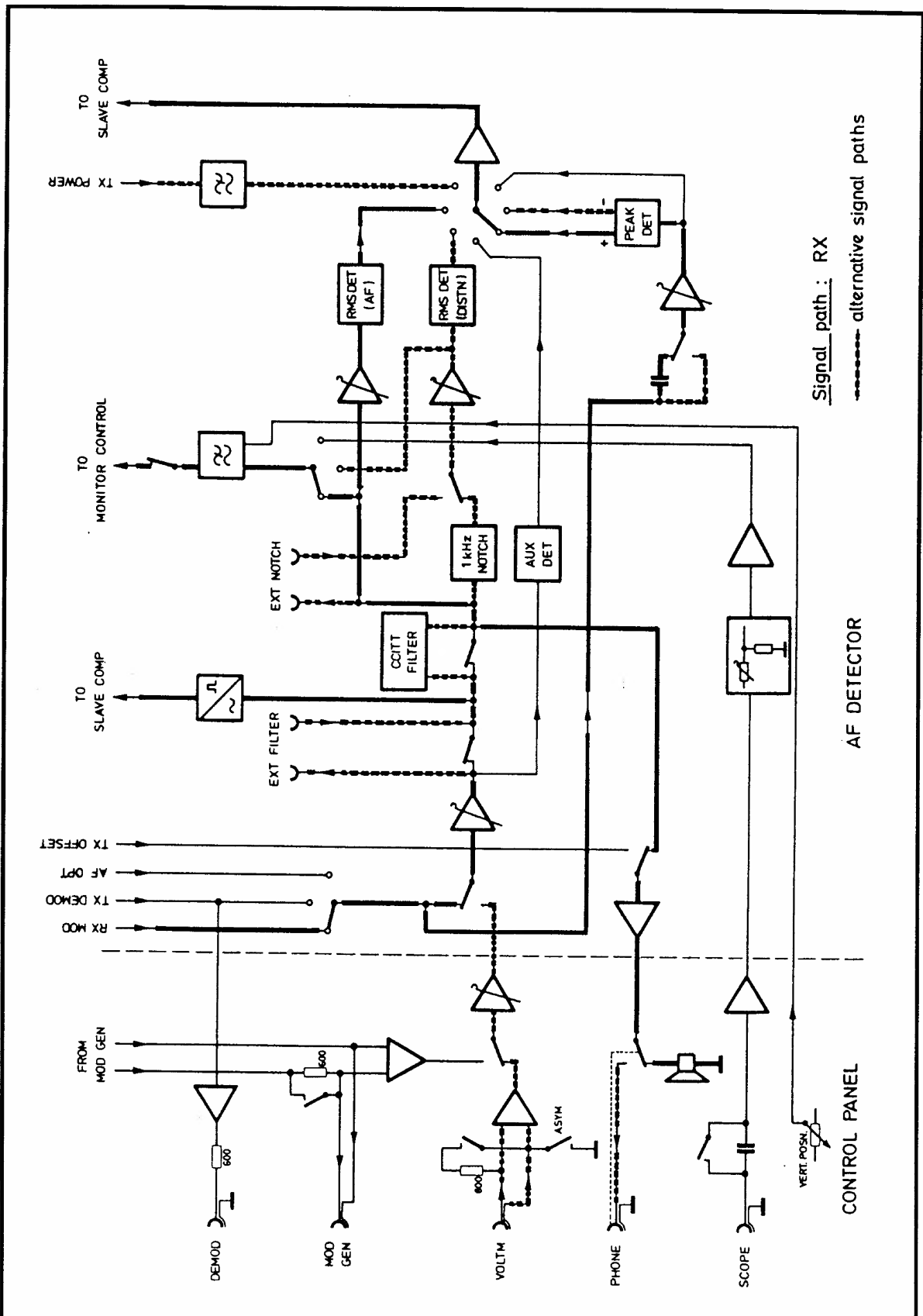

Ref. No. 209 031 F Type 4031	Sub AF Detector Unit	Date
		Sheet 7/11

AF filters

a) CCITT filter

The psophometric filter weights an AF signal according to CCITT standard P 53 and roughly corresponds to the curve of human hearing.

CCITT frequency response:

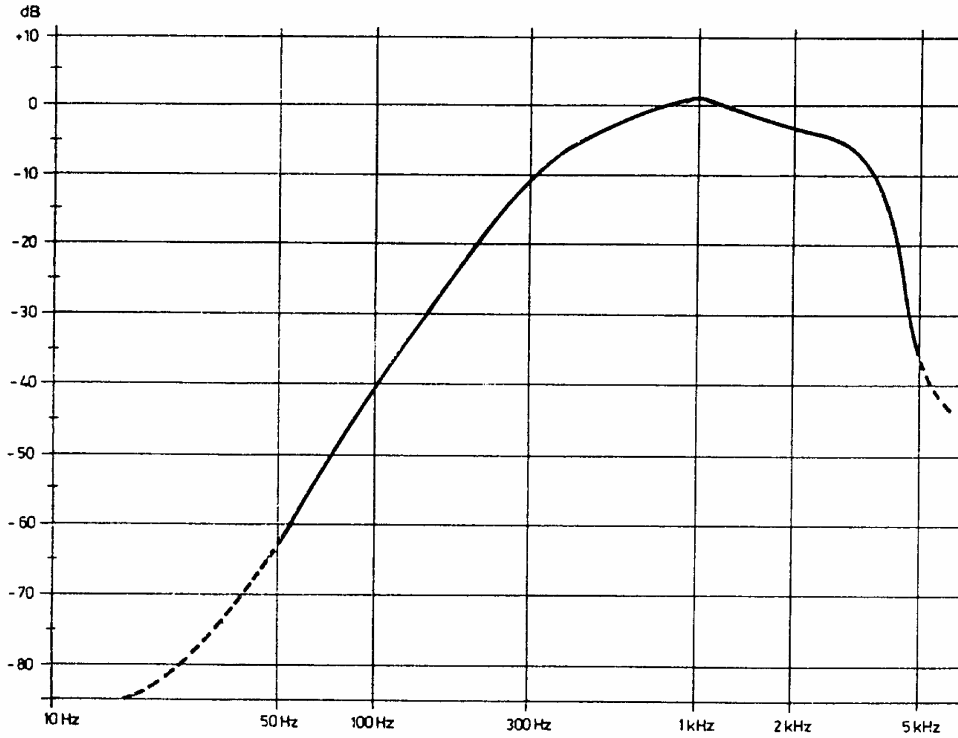

Ref. No. 209 031 F	Sub AF Detector	Date
Type 4031	Unit	Sheet 8/11
Schlumberger	Functional Description	

b) 1-kHz notch filter

For distortion and SINAD measurement the 1-kHz fundamental is rejected by a notch filter. The residual voltage and the total voltage are each measured by an RMS detector to form a ratio. The filter has a width of  $\pm 5$  Hz with attenuation of  $> 60$  dB.

Frequency response:

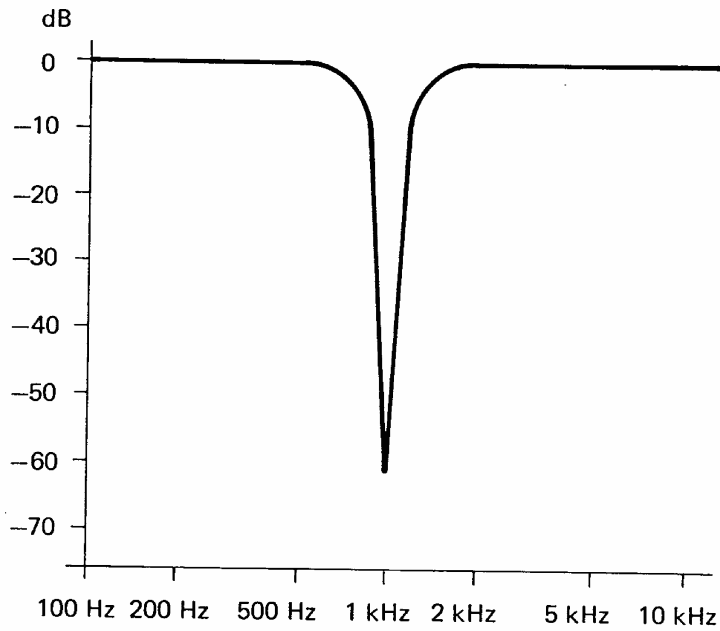

Ref. No. 209 031 F  
Type 4031

Sub AF Detector  
Unit

Date  
Sheet 9/11

Schlumberger

Functional Description

### Oscilloscope

The signal on the SCOPE input is applied either AC-coupled or DC-coupled to impedance transformer A3.

On the AF detector it is divided according to the different vertical deflection coefficients (2/4/10/20/40/100/200/400) by the switchable voltage divider D100 and R100 through R113 and amplified again by A100. The following multiplexer D101 switches the external signal or the internal voltage before the RMS converter or the residual distortion signal via an anti-aliasing filter A101 to the data-acquisition system on the monitor-control circuit board.

The anti-aliasing filter has a cutoff frequency (-3 dB) of 35 kHz. A DC voltage is also added that has been set with the POSition potentiometer on the front panel.

### 8-MHz converter

The highly stable 10-MHz sinewave signal is first reshaped into a TTL squarewave by D1 and divided by five in divider D2. The 2 MHz is then mixed with 10 MHz in an exclusive-OR gate D1. The 8-MHz mixture product is filtered out by the following bandpass filter and used as the system timing for all microprocessors. The 8-MHz converter is located on a separate PCB (361 483) in order to suppress spurious signals.

Ref.No. 209 031 F	Sub AF Detector	Date
Type 4031	Unit	Sheet 10/11
Schlumberger		Functional Description



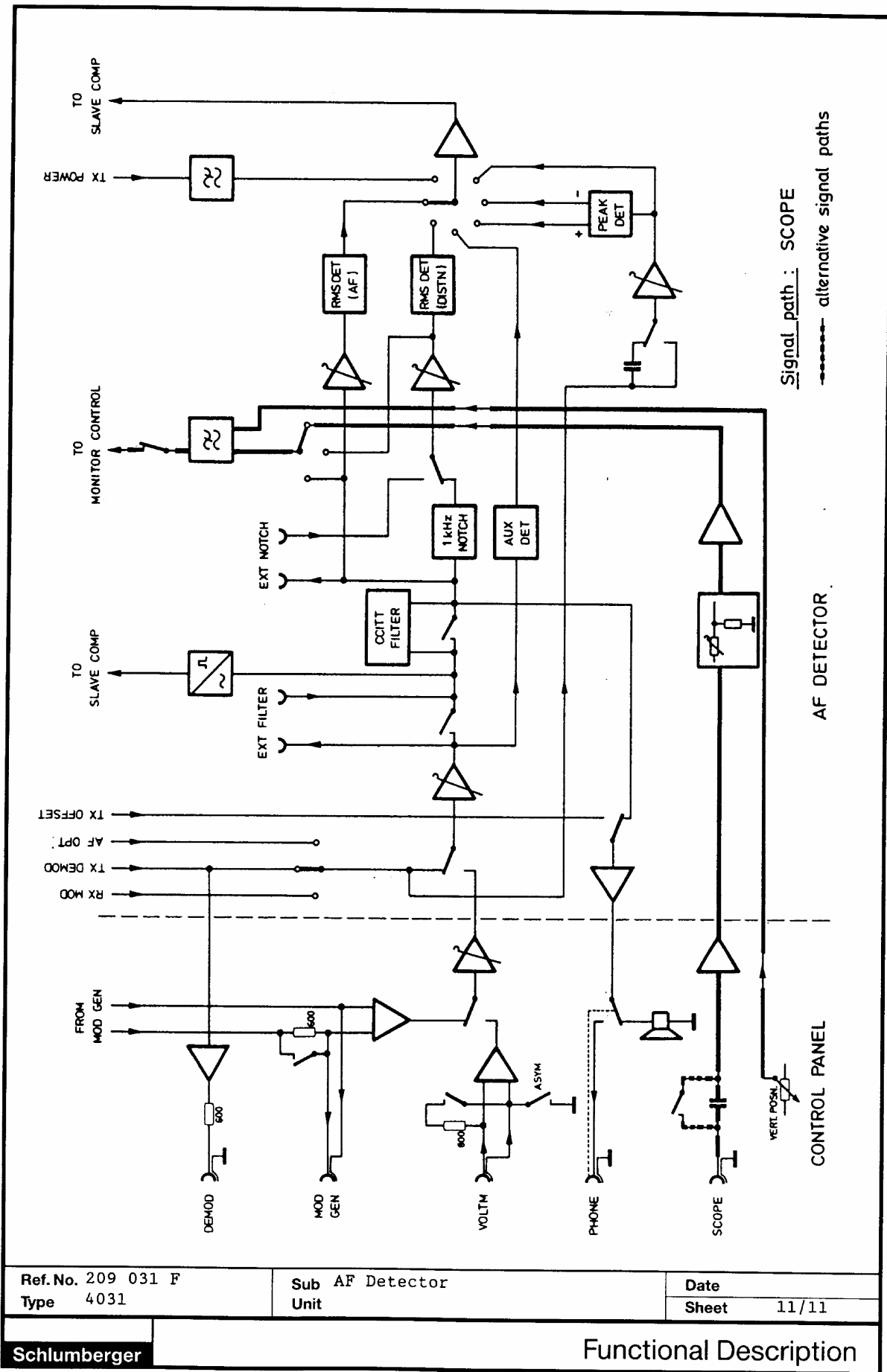

Ref. No. 209 031 F  
 Type 4031

Sub AF Detector  
 Unit

Date  
 Sheet 11/11

Necessary Equipment	Measuring Procedure	Measuring Point	Frequency	Adjustment	Set Value	Actual Value	Issue	Alteration No.	Date	Name	Issue	Alteration No.	Date	Name	Ref. No.	Sub Unit	AF Detector	Sheet
4031, DVM  Oscilloscope	<u>Testing ±6-V power unit</u>  <u>Peak detector</u> RX FM: press EXT key Mod. frequency = 1 kHz Mod. = 2.4 kHz $\hat{=}$ 0.34 V on Mp8 Mod. = 20 kHz $\hat{=}$ 2.83 V on Mp8  <u>AC voltmeter</u> TX: Mod Gen display Mod. frequency = 1 kHz Level = 4 mV $\hat{=}$ 532 mV on Mp6 200 mV $\hat{=}$ 2.66 V on Mp6 400 mV $\hat{=}$ 5.32 V on Mp6 800 mV $\hat{=}$ 1.064 V on Mp6  <u>Monitoring amplifier</u> Turn up volume control on front panel	Mp28 Mp29  Mp13 Mod. meter Mp13 Mod. meter  Mp20 RMS meter Mp20 RMS meter Mp20 RMS meter Mp20 RMS meter	DC DC  1 kHz 1 kHz  1 kHz 1 kHz 1 kHz 1 kHz  1 kHz	7.1 V $\pm$ 0.3 V 6.1 V $\pm$ 0.3 V  1.7 V $\pm$ 50 mV $\pm$ 2.4 kHz $\pm$ 50 Hz 2.83 V $\pm$ 0.1 V $\pm$ 20 kHz $\pm$ 500 Hz  2.83 V $\pm$ 50 mV 4 mV $\pm$ 1 mV 2.83 V $\pm$ 50 mV 200 mV $\pm$ 5 mV 2.83 V $\pm$ 50 mV 400 mV $\pm$ 10 mV 2.83 V $\pm$ 50 mV 800 mV $\pm$ 20 mV  Sound audible											209 031 A	AF	Detector	1/3





214 031 5  
10 MHz REFERENCE

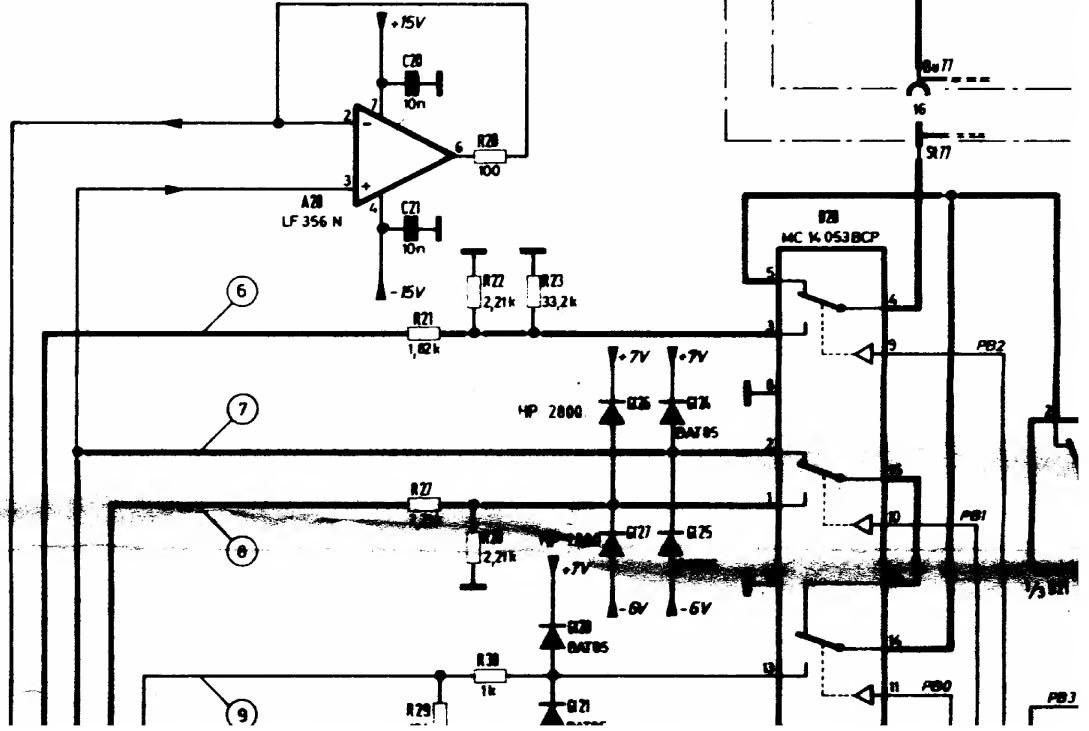
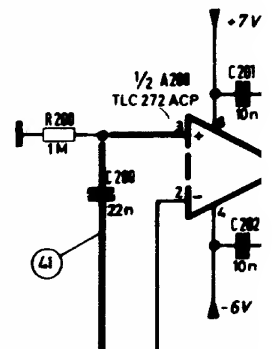
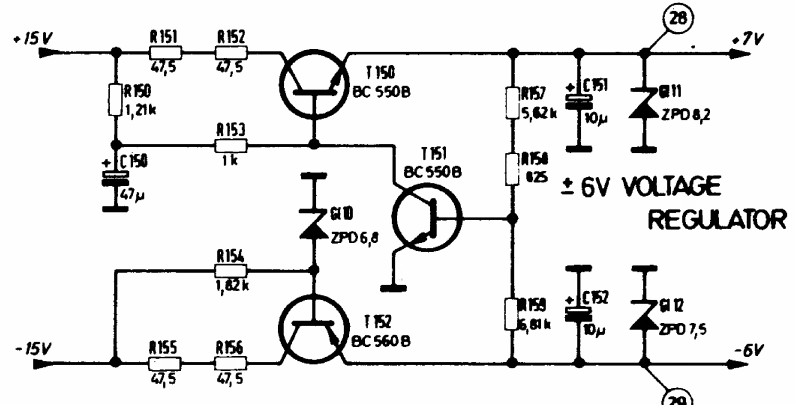
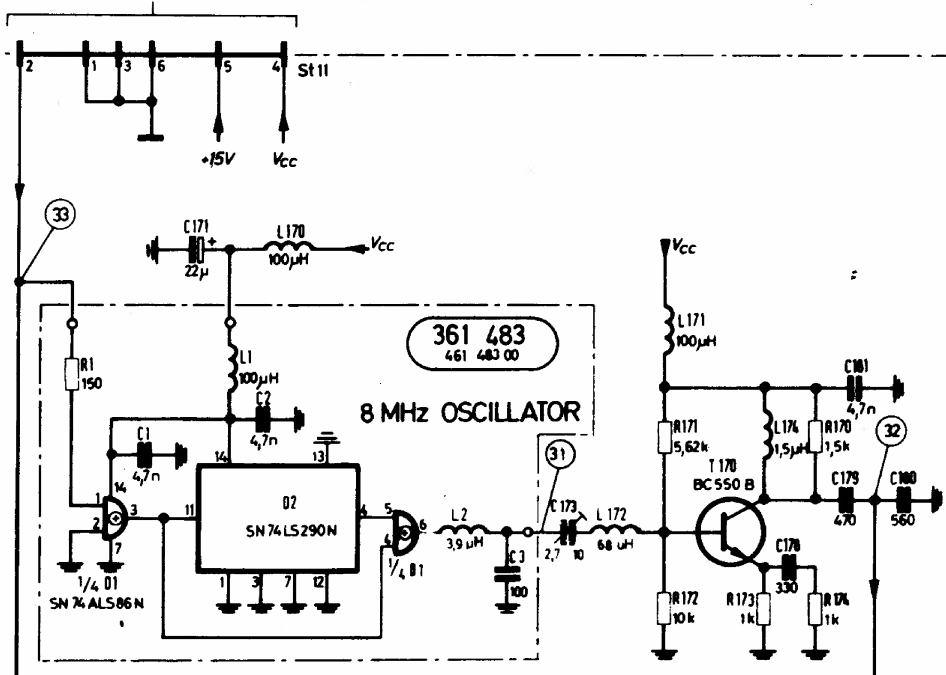

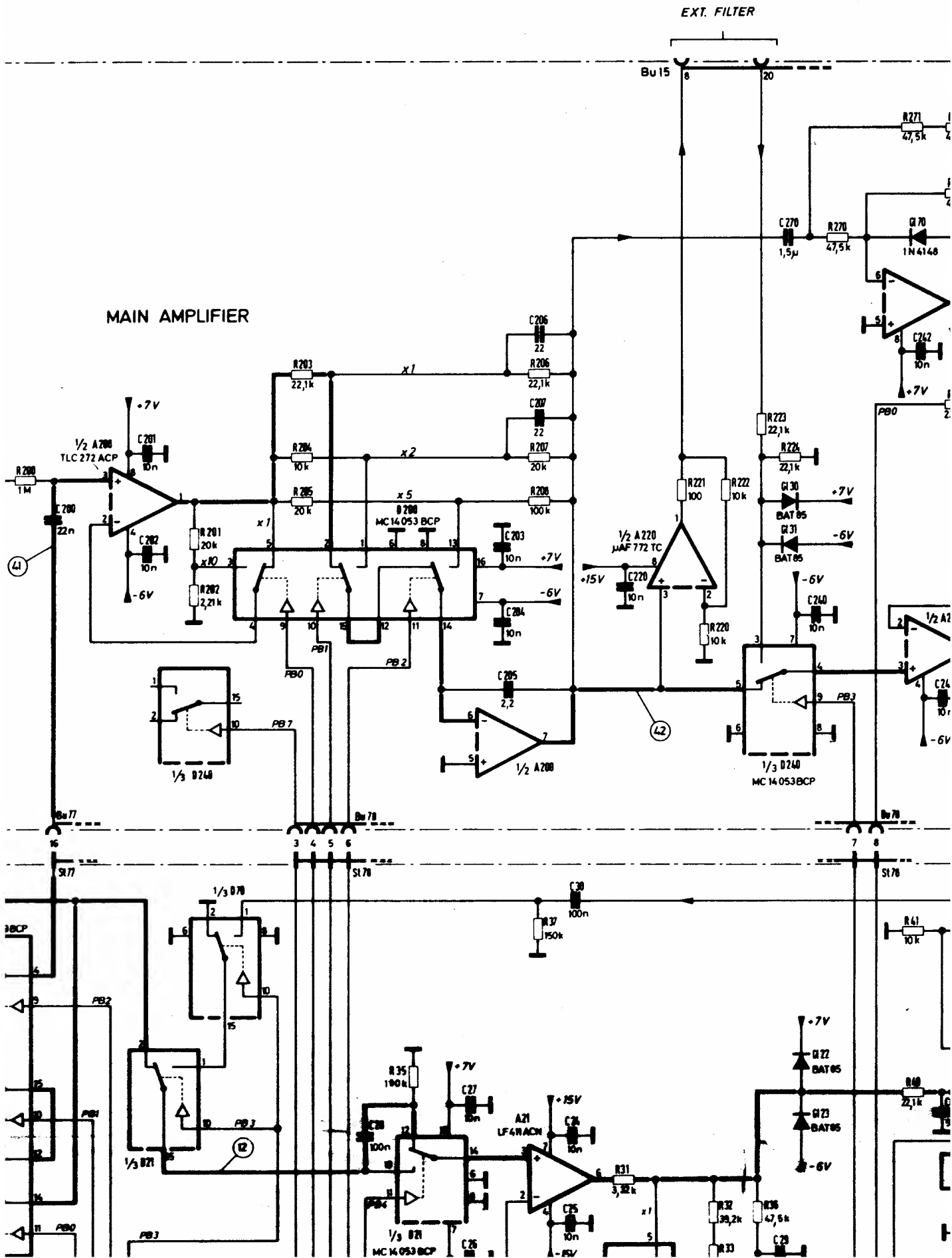

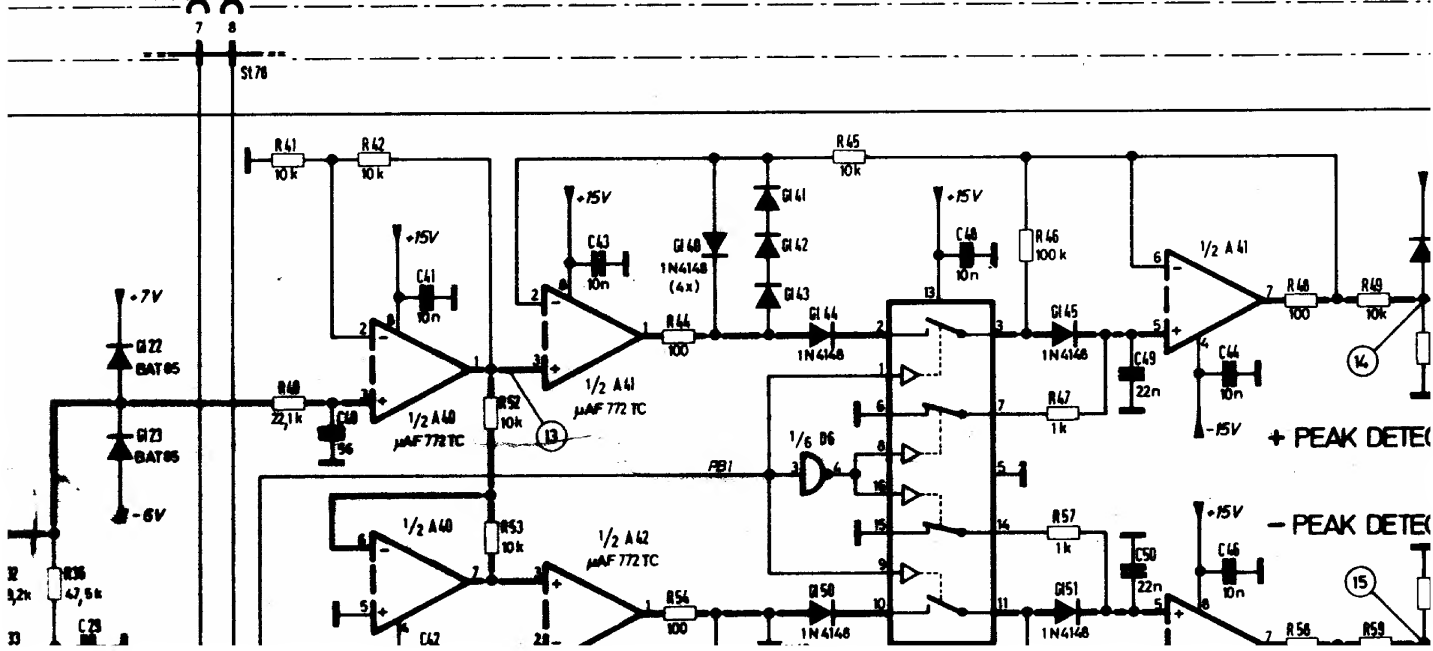
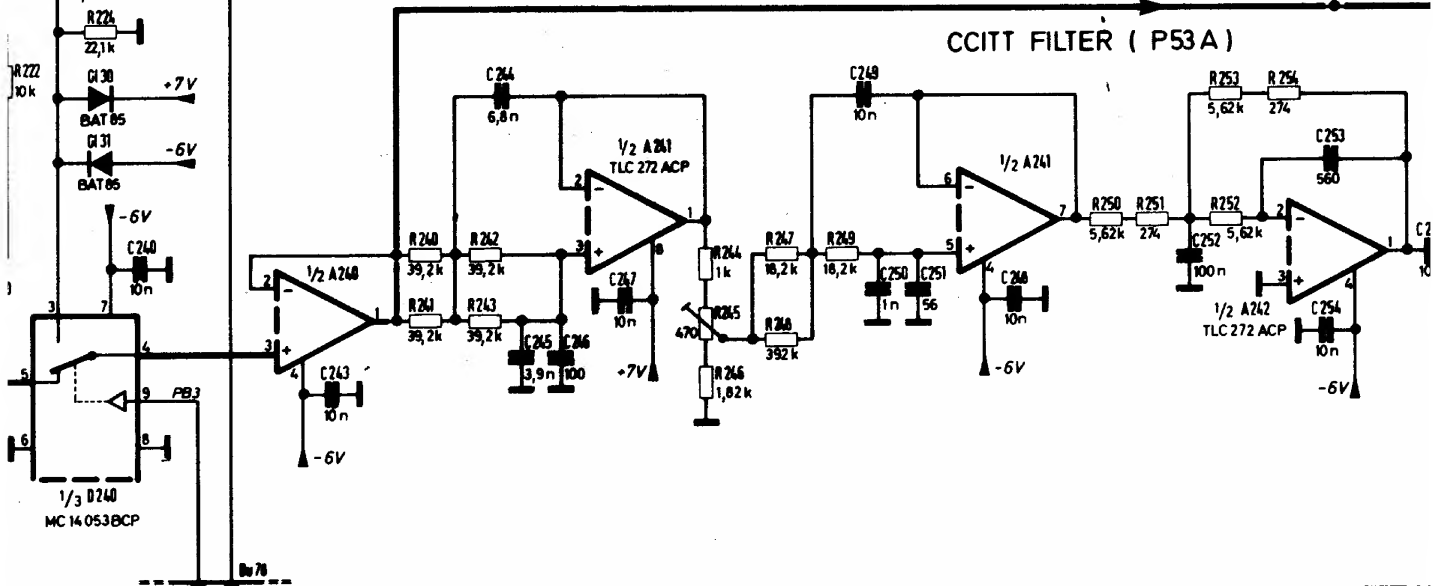
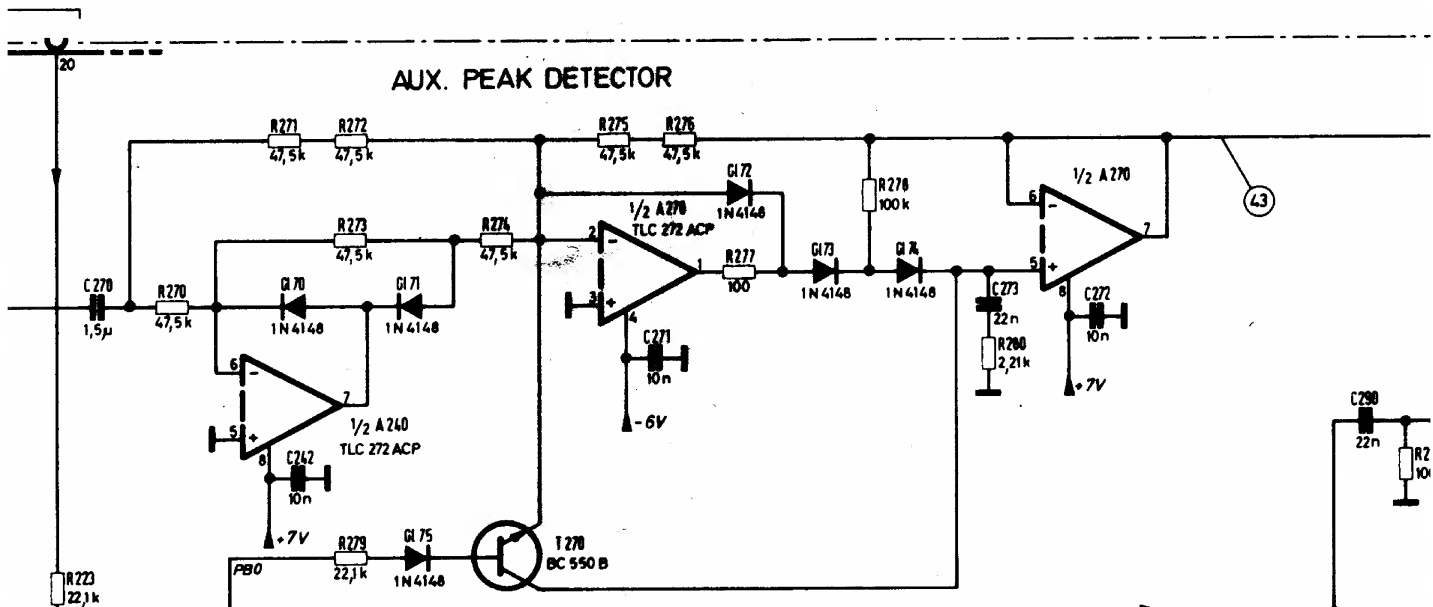

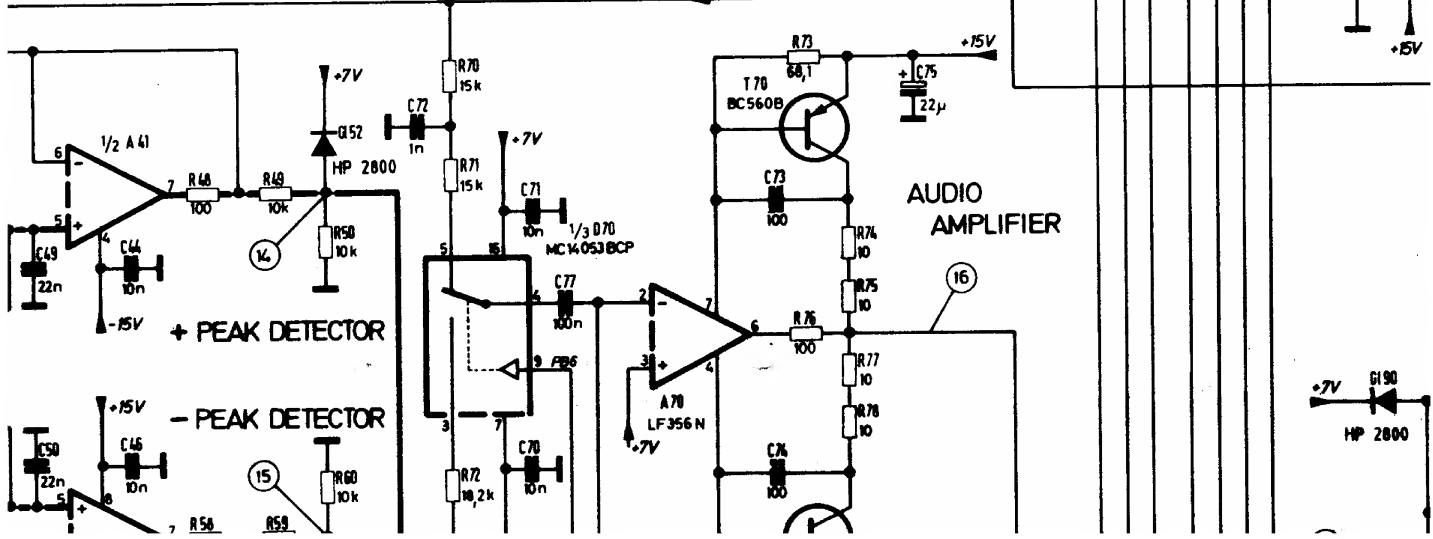
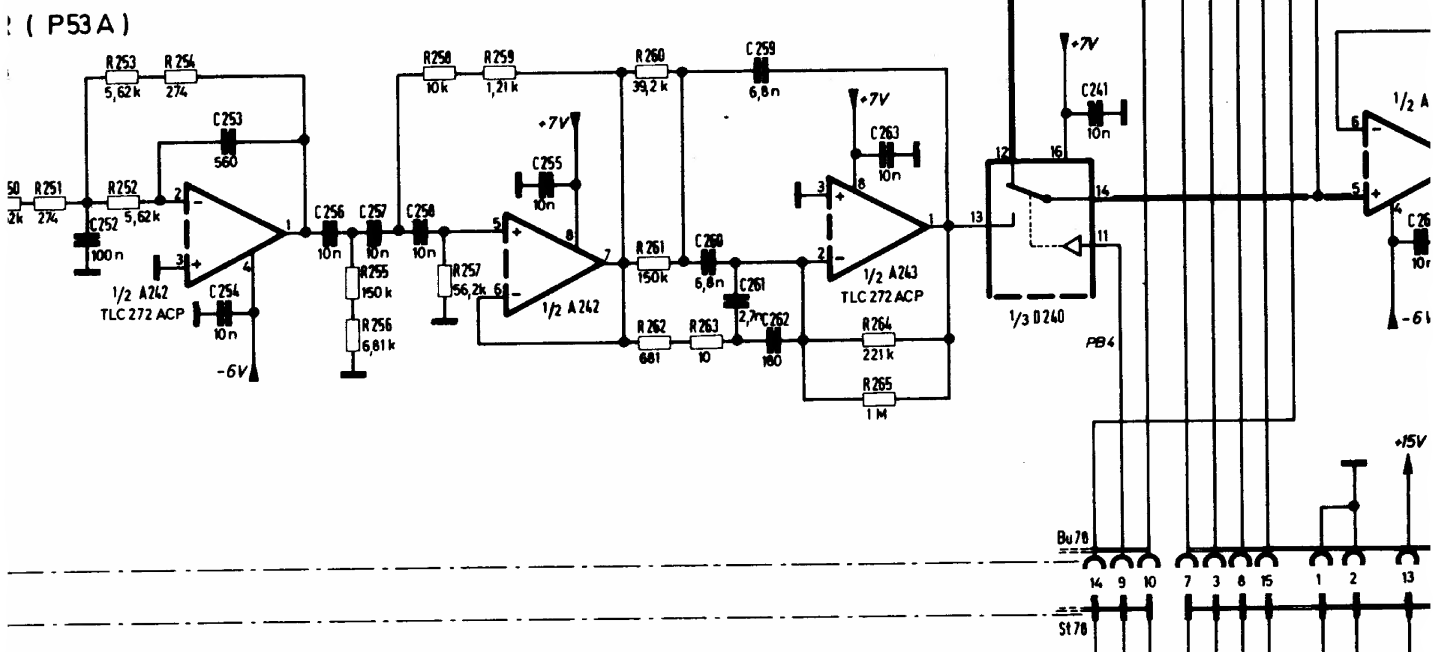
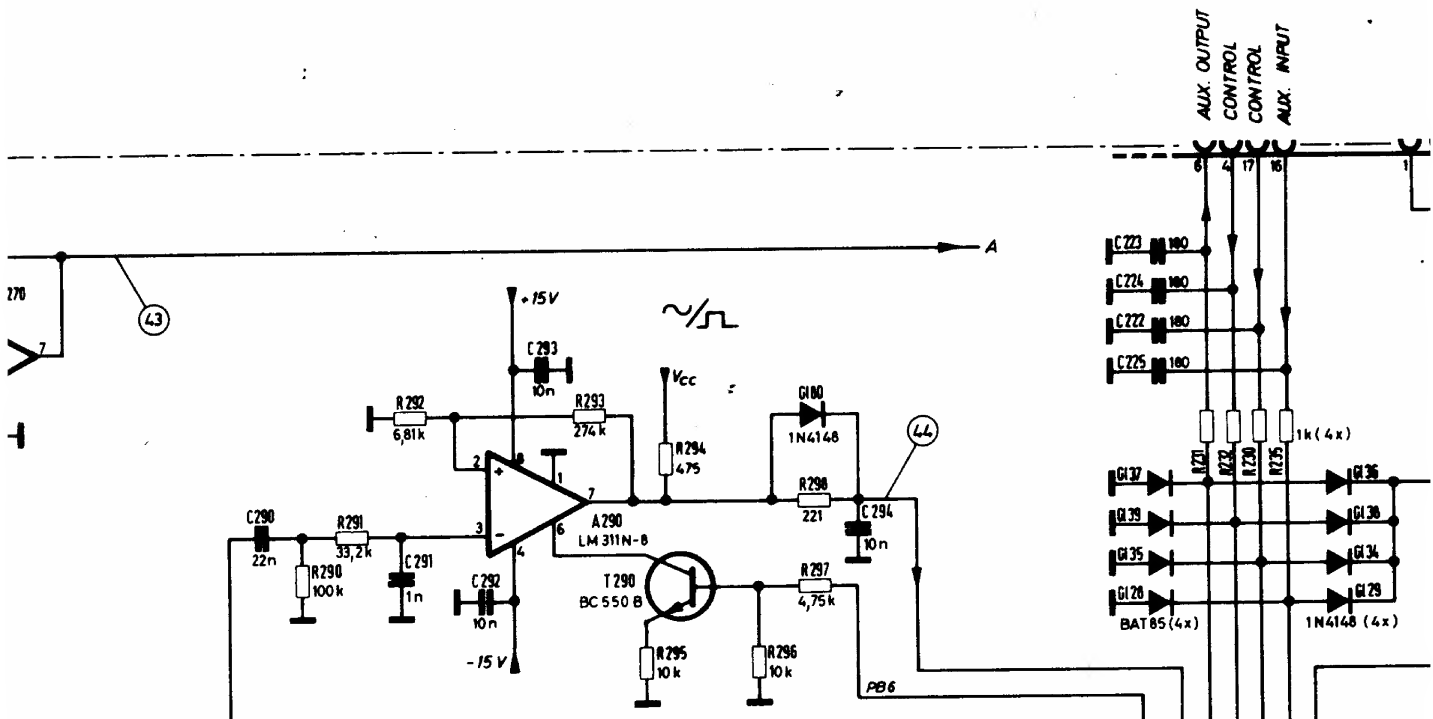

AUX OUTPUT  
CONTROL  
CONTROL  
AUX INPUT

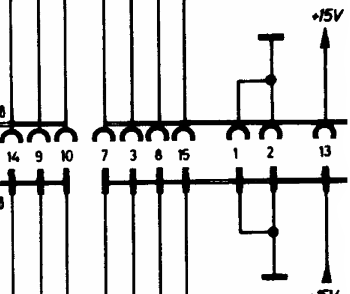
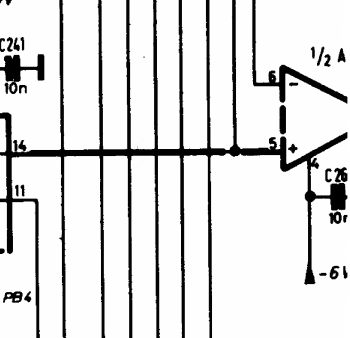
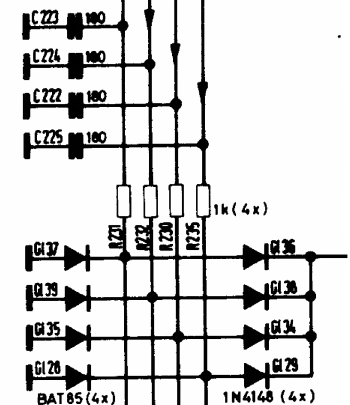



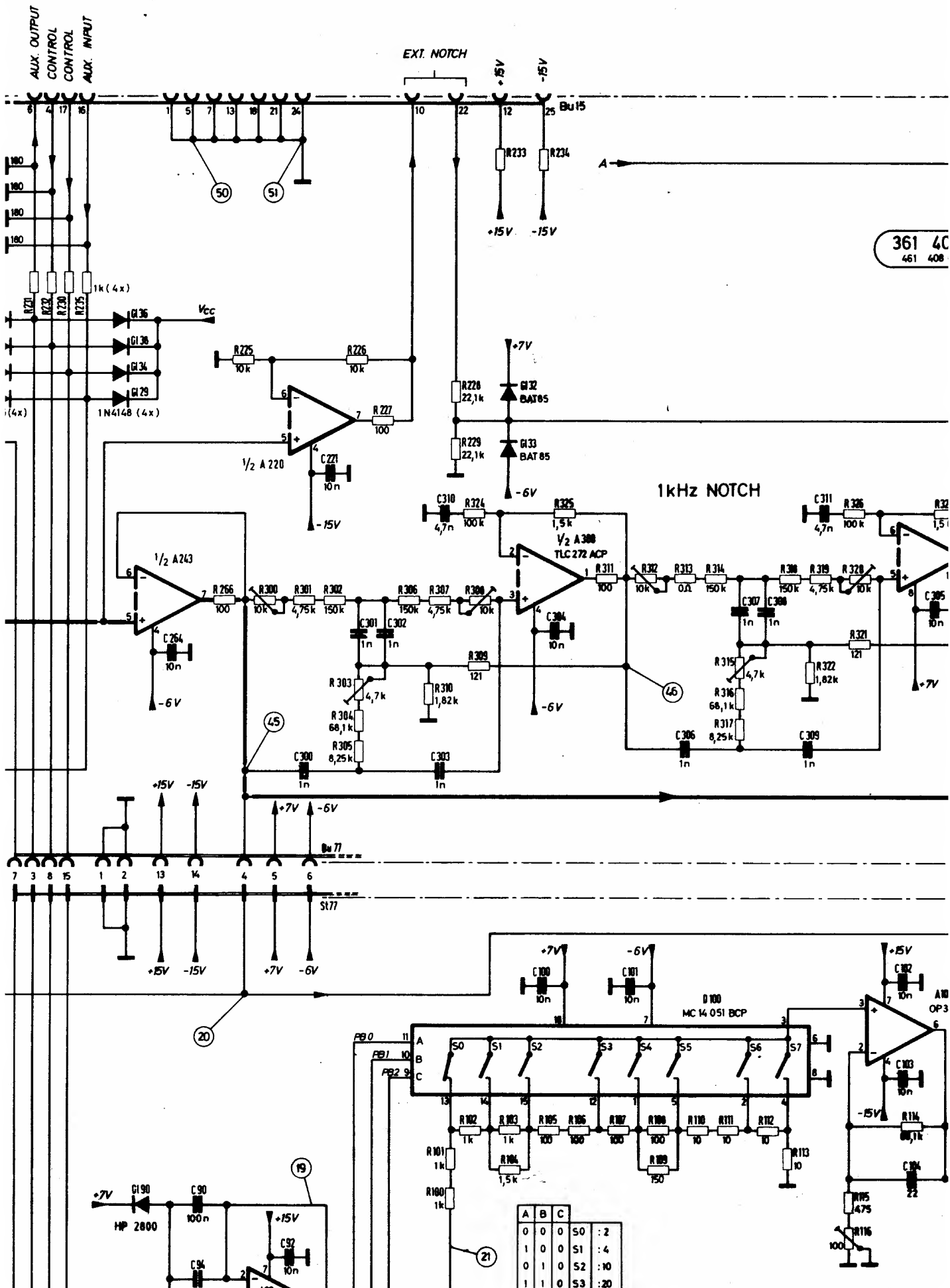

361 40  
461 408

A	B	C	Output
0	0	0	S0 : 2
1	0	0	S1 : 4
0	1	0	S2 : 10
1	1	0	S3 : 20

RMS CONV. ( DISTORSION - MODE )

361 408  
461 408 02

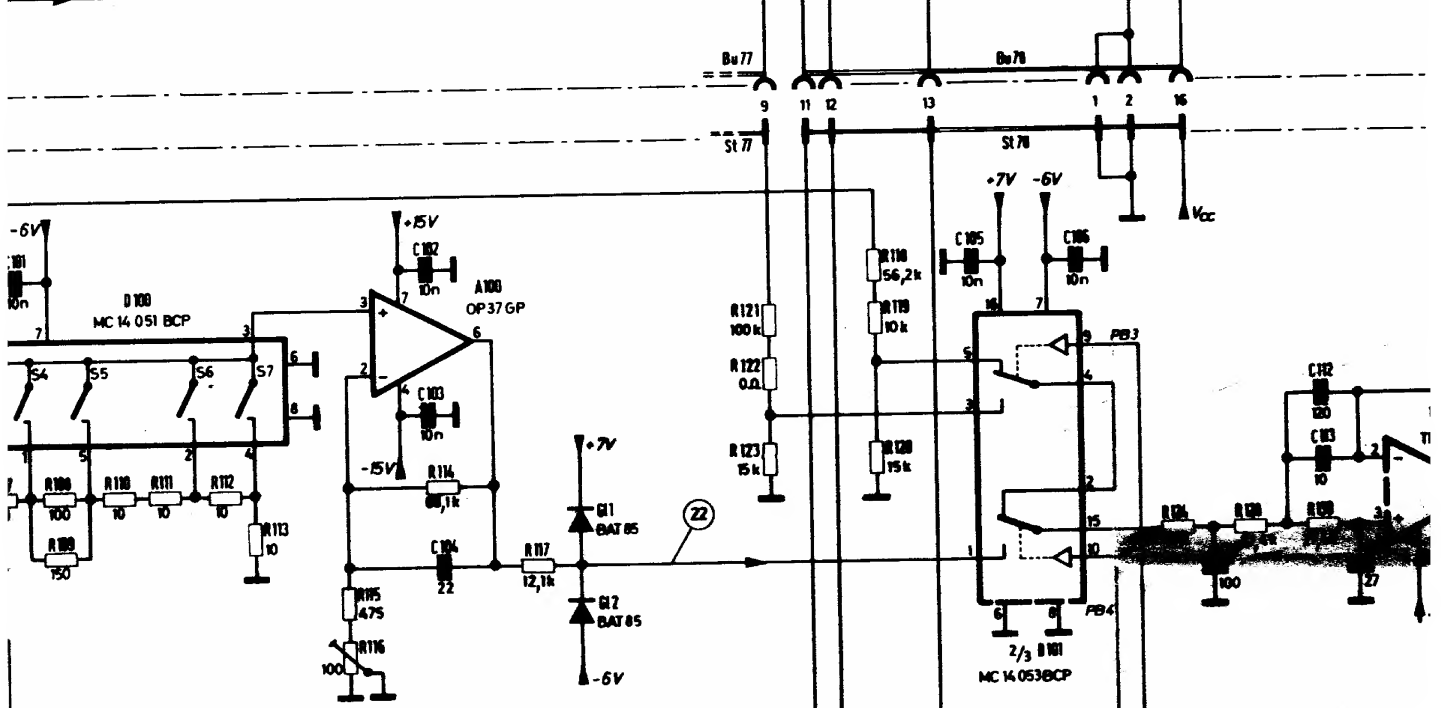
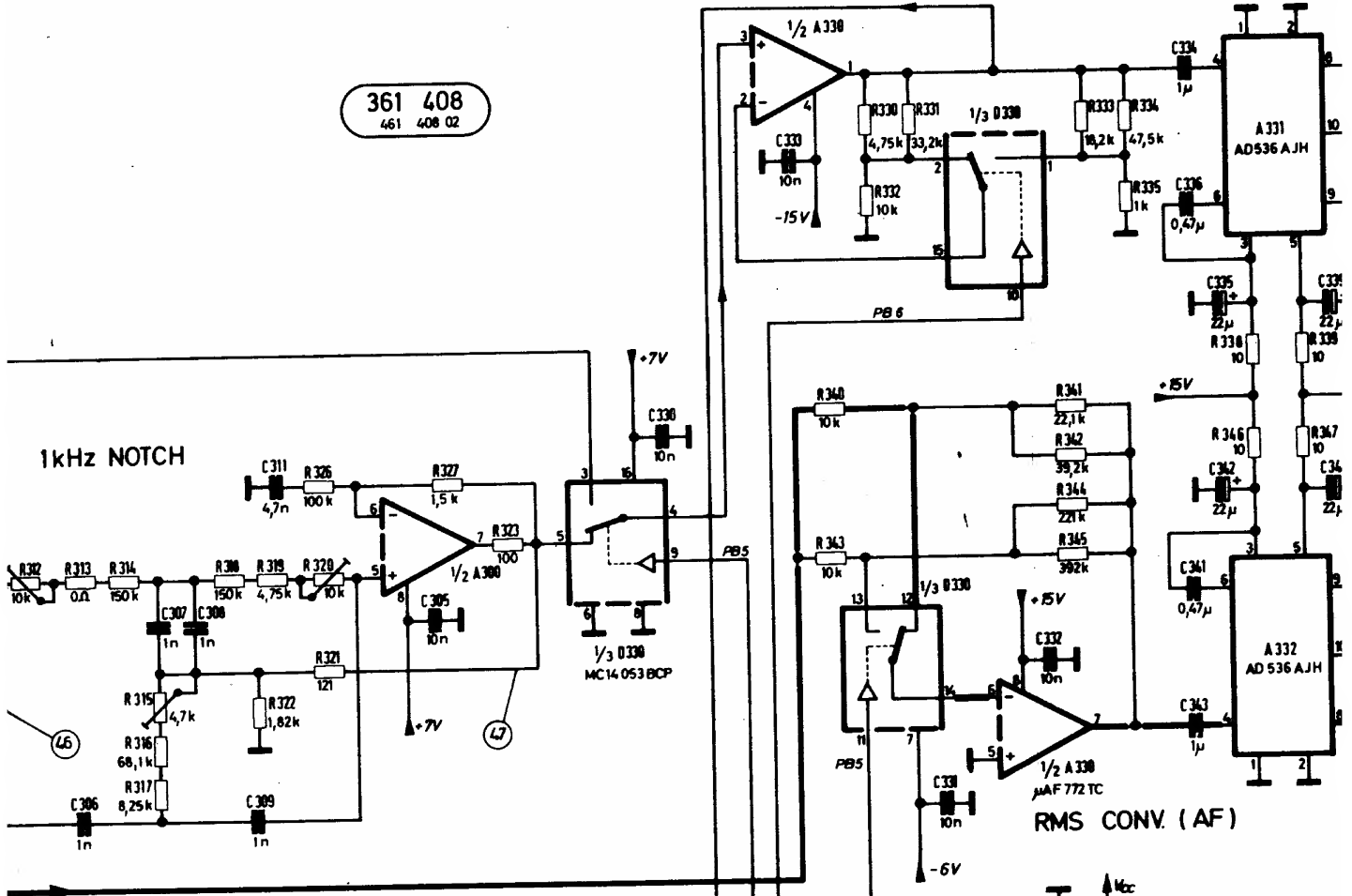

AS CONV. ( DISTORSION - MODE )

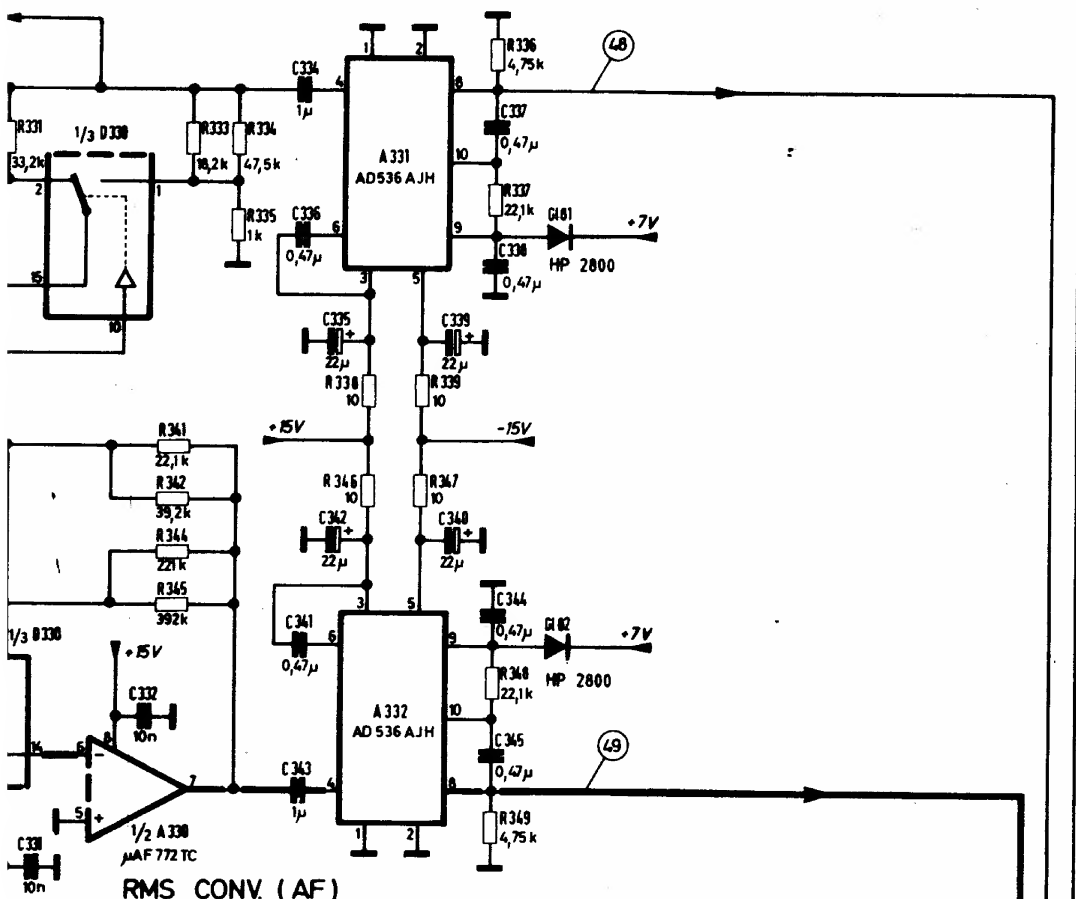

RMS CONV. (AF)

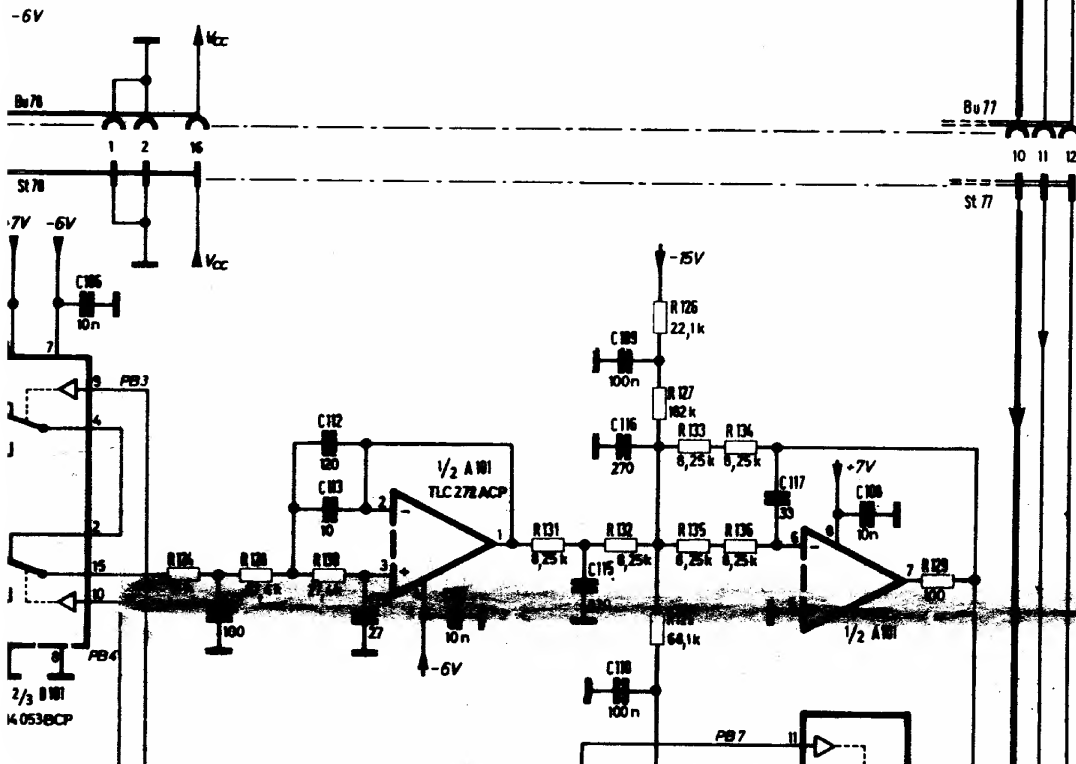

ADDR. DECODER

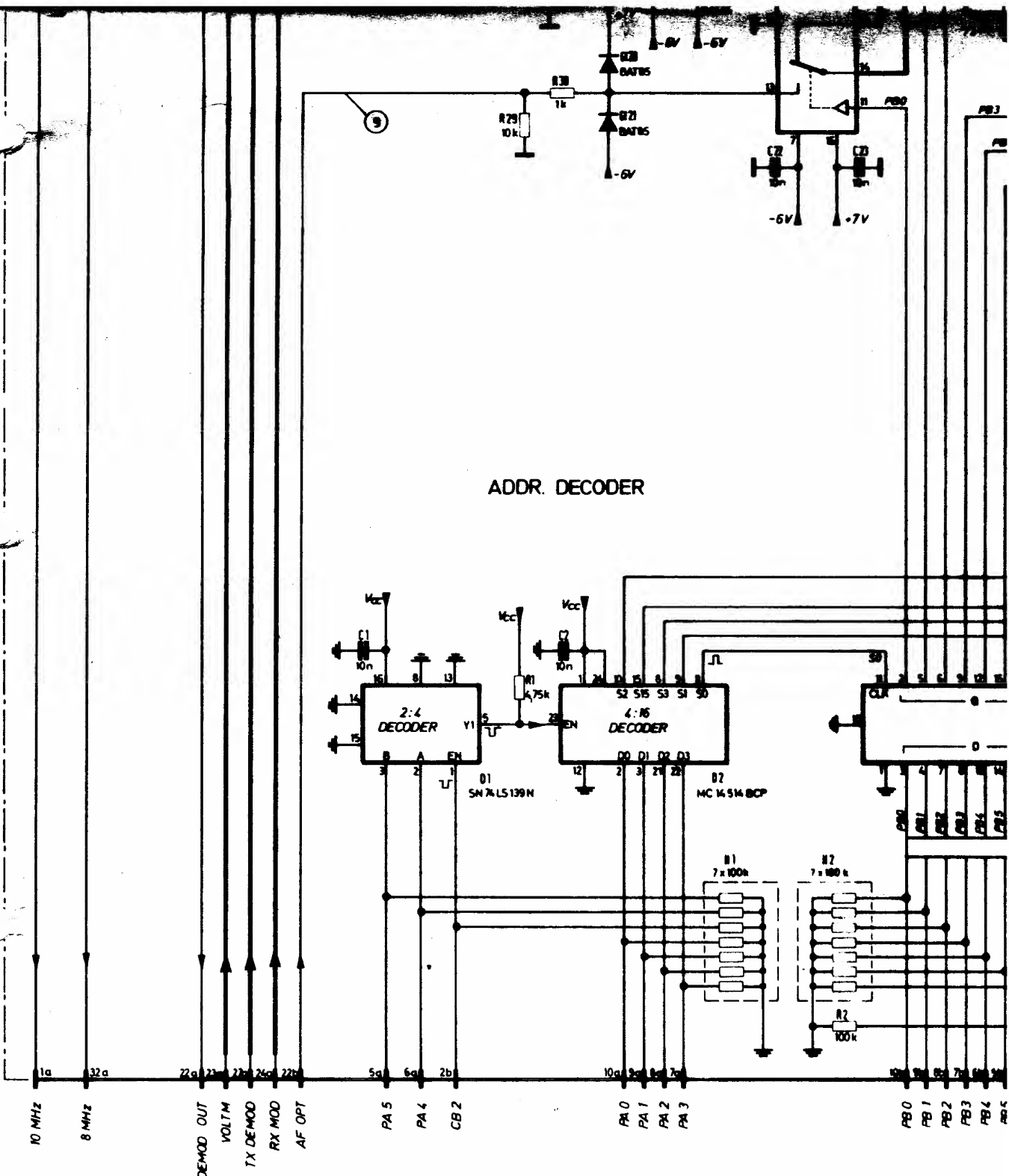

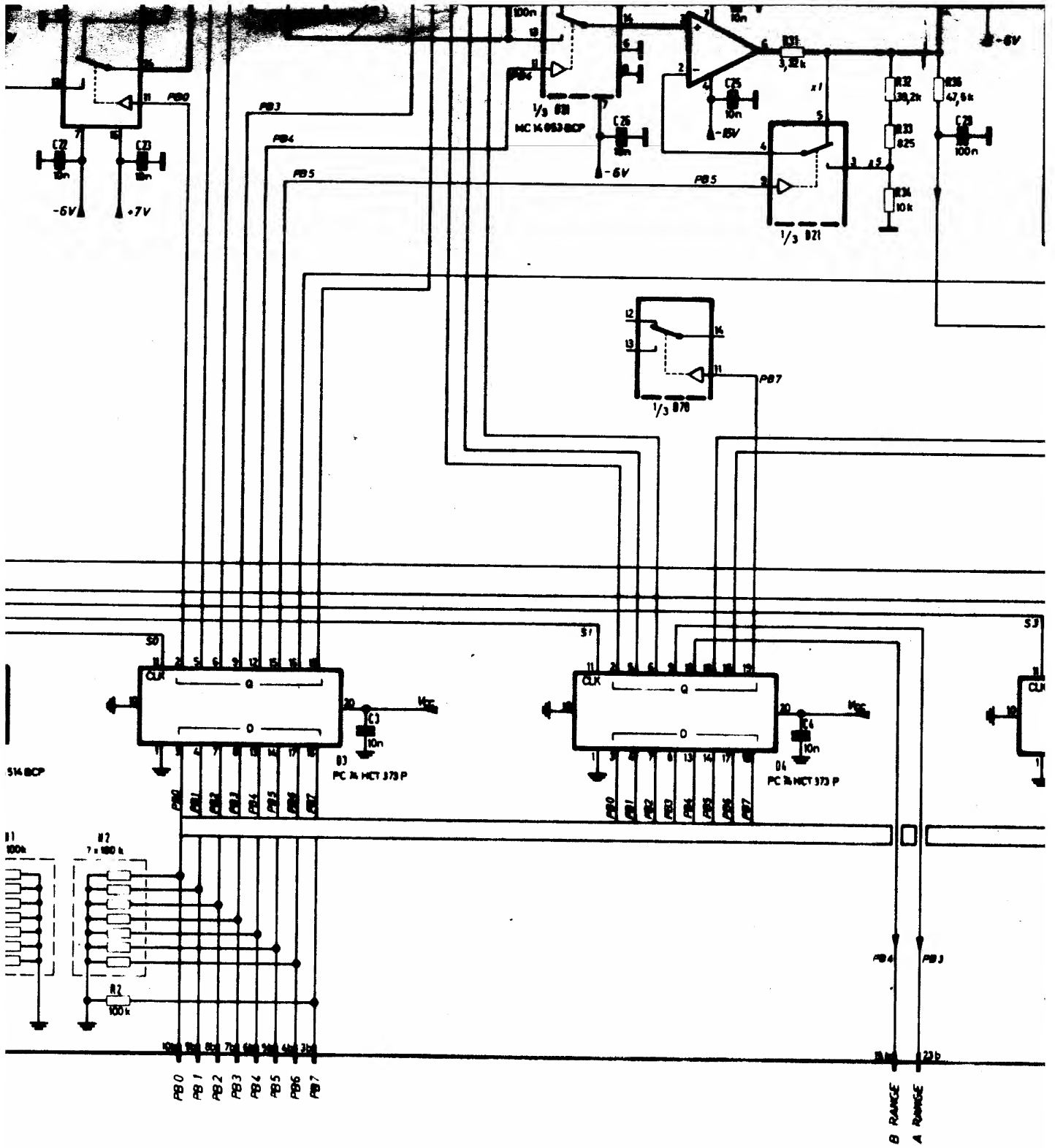

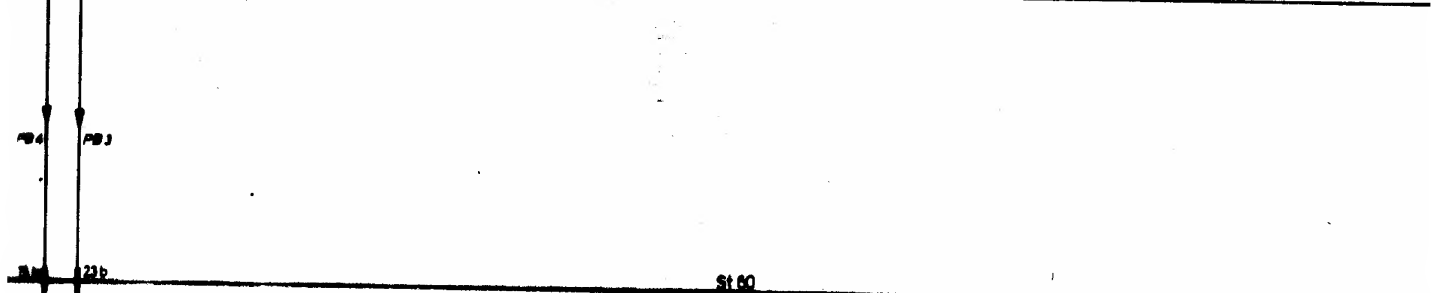
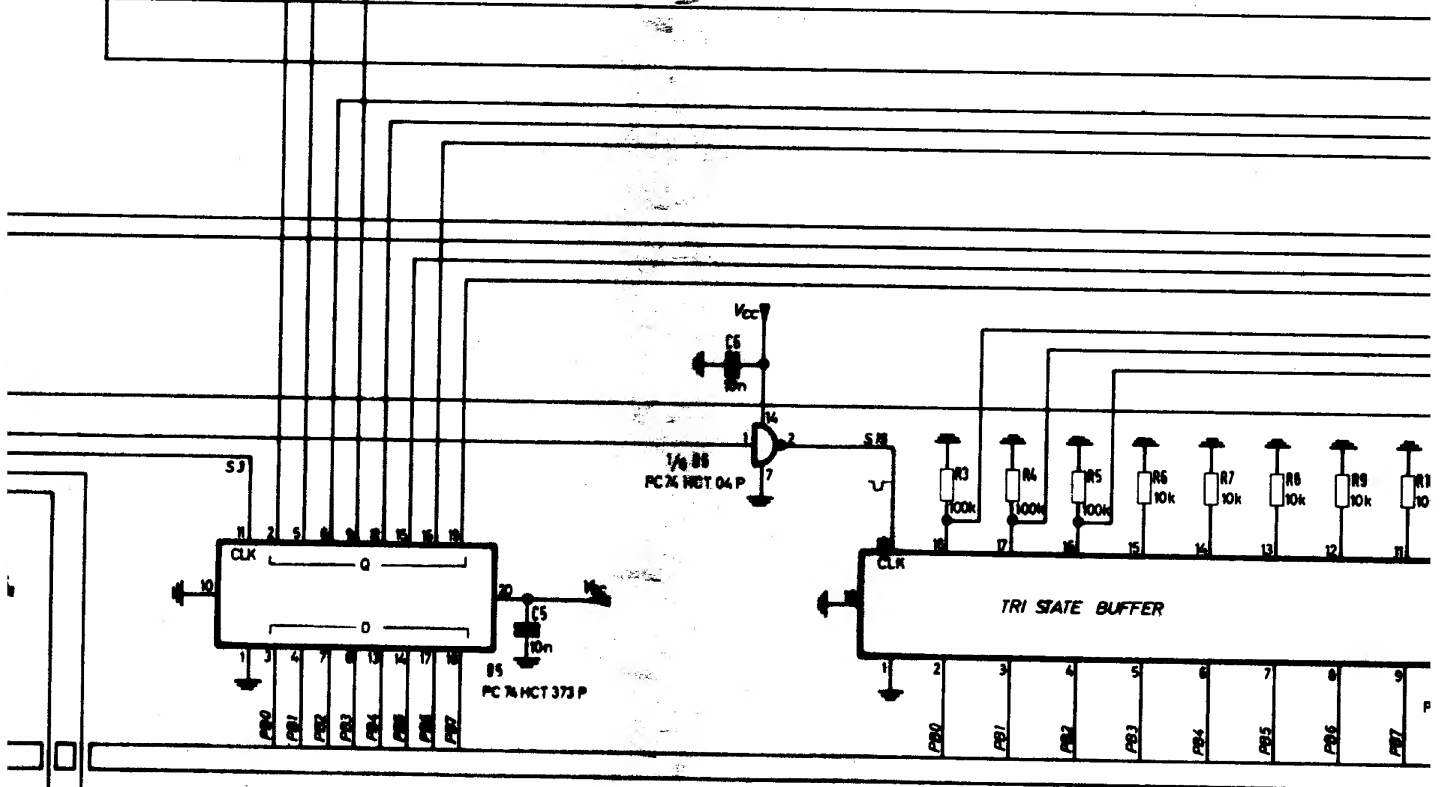
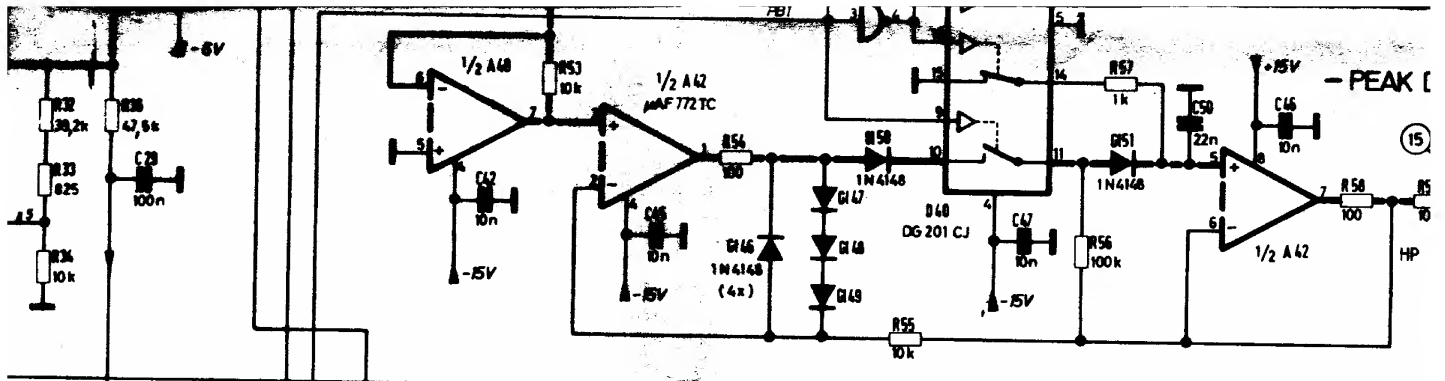

B RANGE  
A RANGE

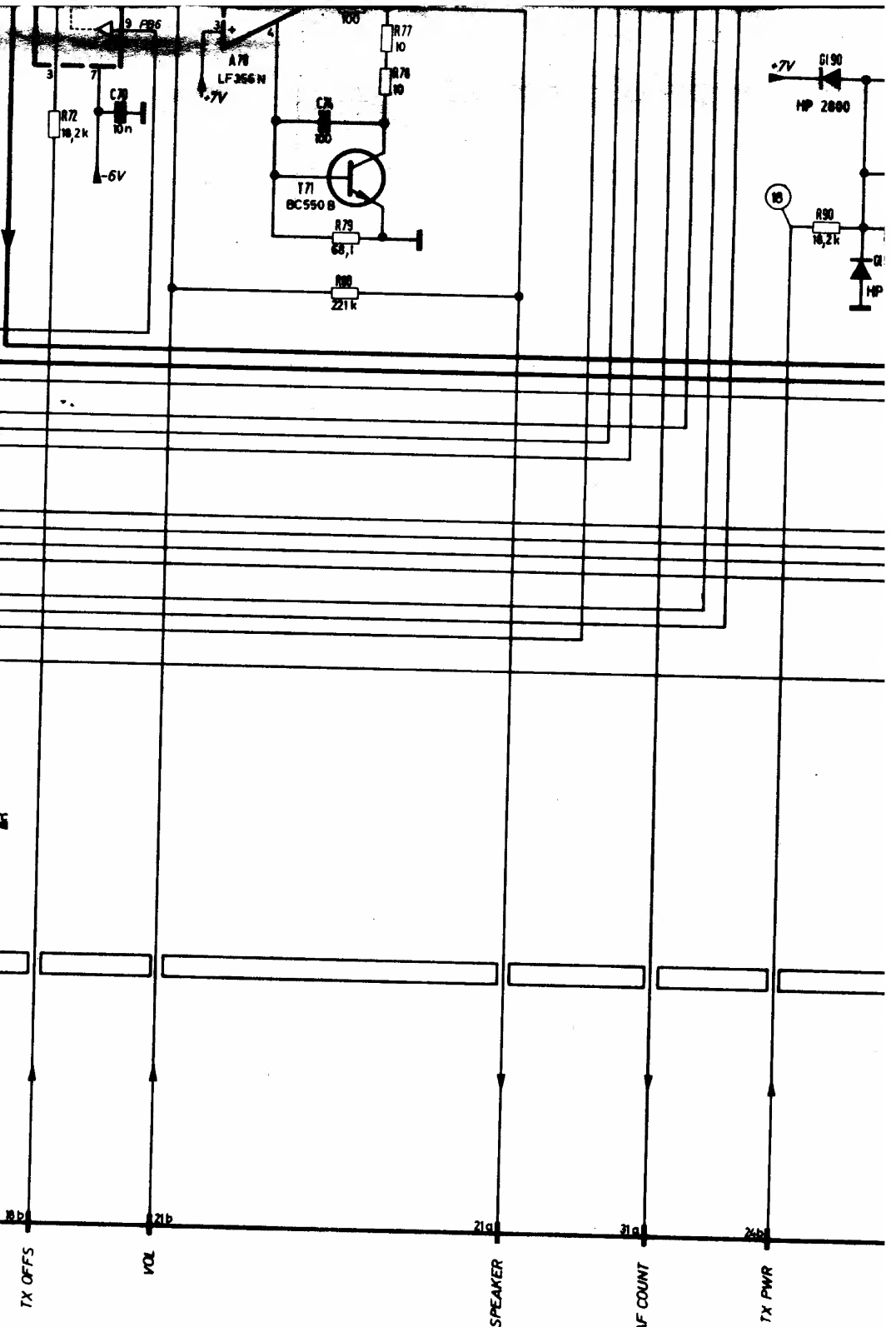
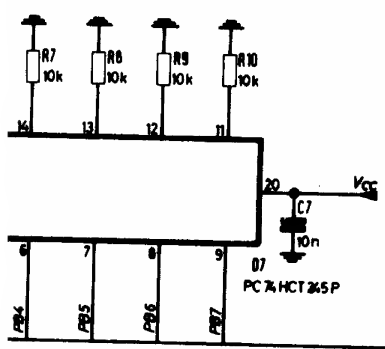
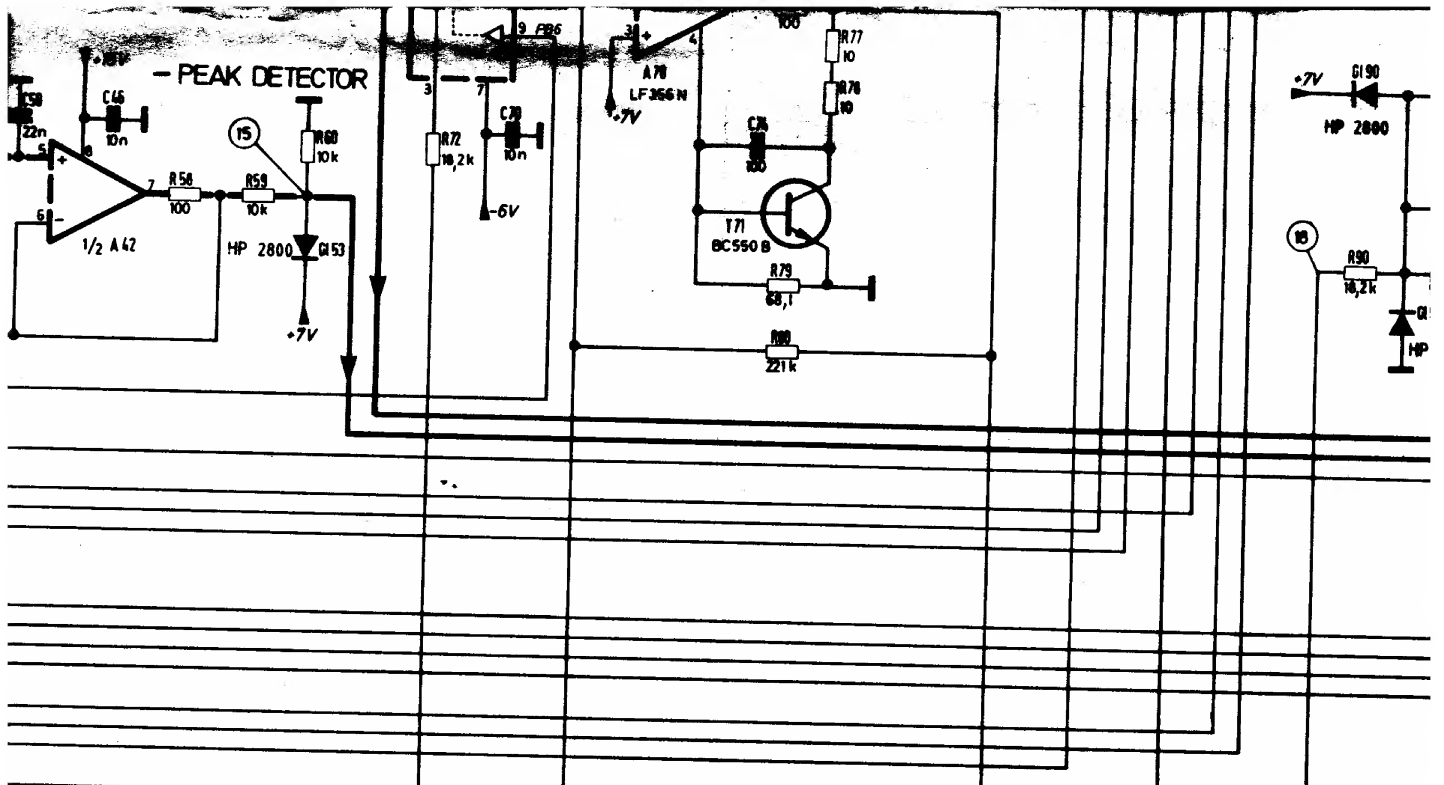

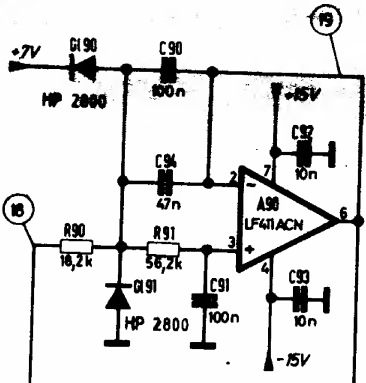

A	B	C	
0	0	0	S0 : 2
1	0	0	S1 : 4
0	1	0	S2 : 10
1	1	0	S3 : 20
0	0	1	S4 : 40
1	0	1	S5 : 100
0	1	1	S6 : 200
1	1	1	S7 : 400

SCOPE AMPLIFIER

361 407  
461 407 83

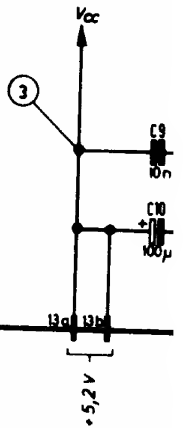
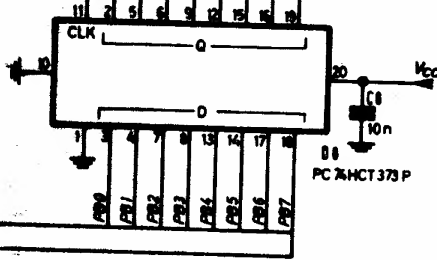

TX PWR

SCOPE

S160

W BLACK	B BLUE
BR BROWN	V VIOLET
R RED	Y YELLOW
RO ROSE	W WHITE
YV YELLOW	TR TRANS
GR GREEN	



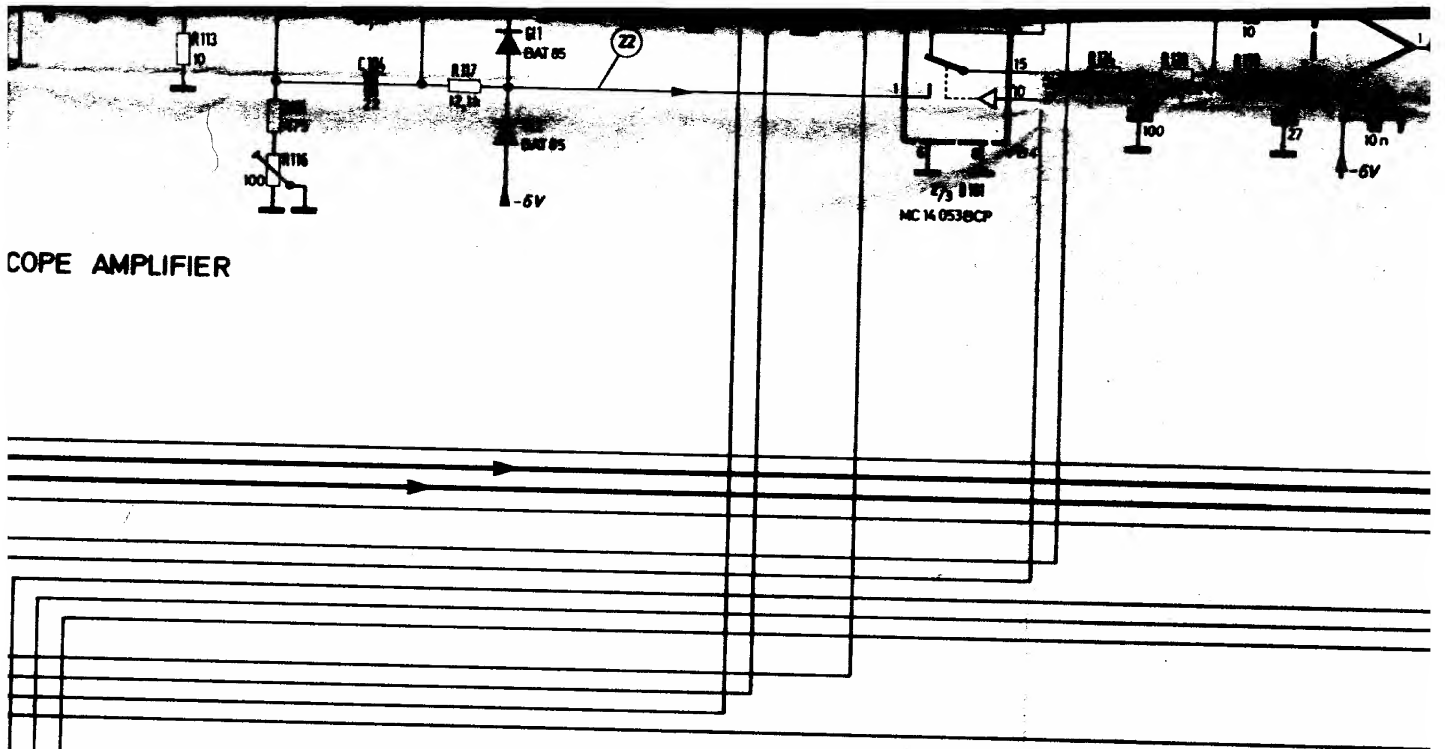

361 407  
461 407 83

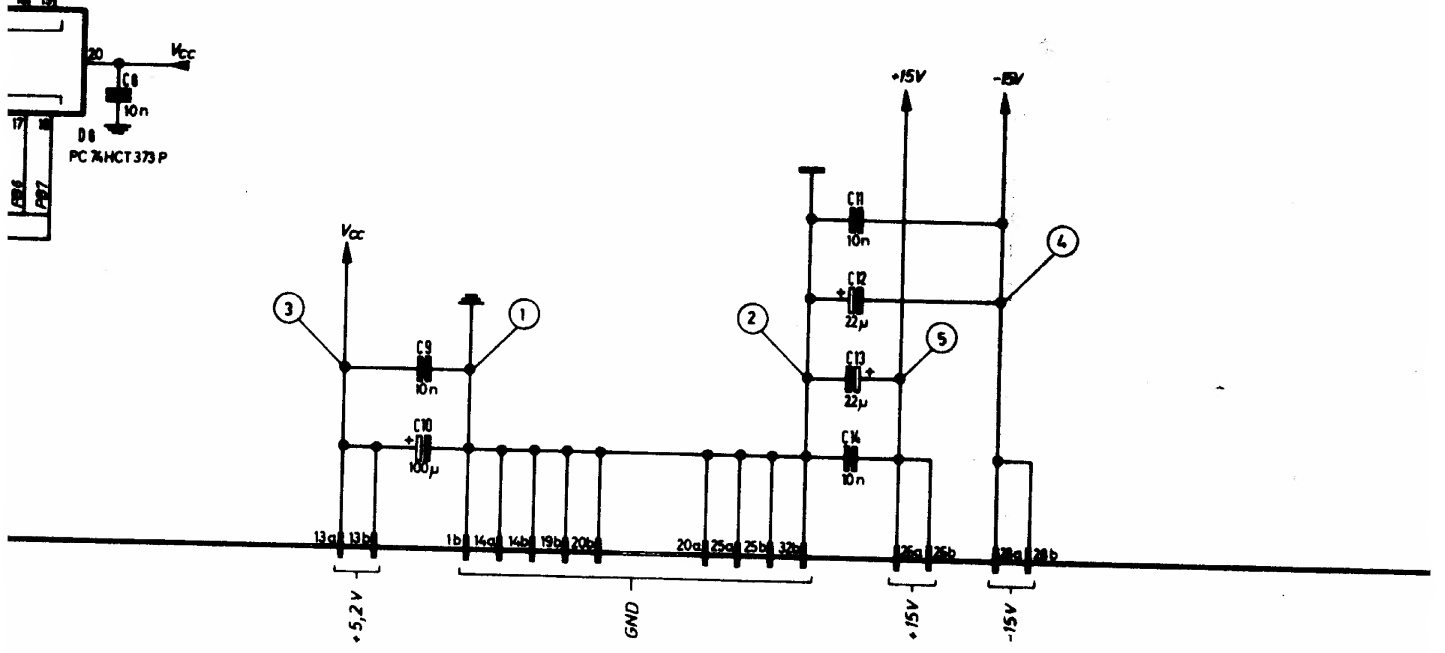

08	8088, 18-	6.10.88	Kr.	1986	11.12.85	Kr.	Schlumberger Meßgeräte GmbH Postfach 10101, D-4000 Düsseldorf 10
Ausg.	A. M. H. G.	DATE	Name	1986	DATE	Name	
ISS	MODIF	DATE	NAME	1986	DATE	NAME	

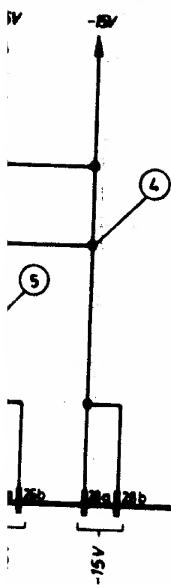
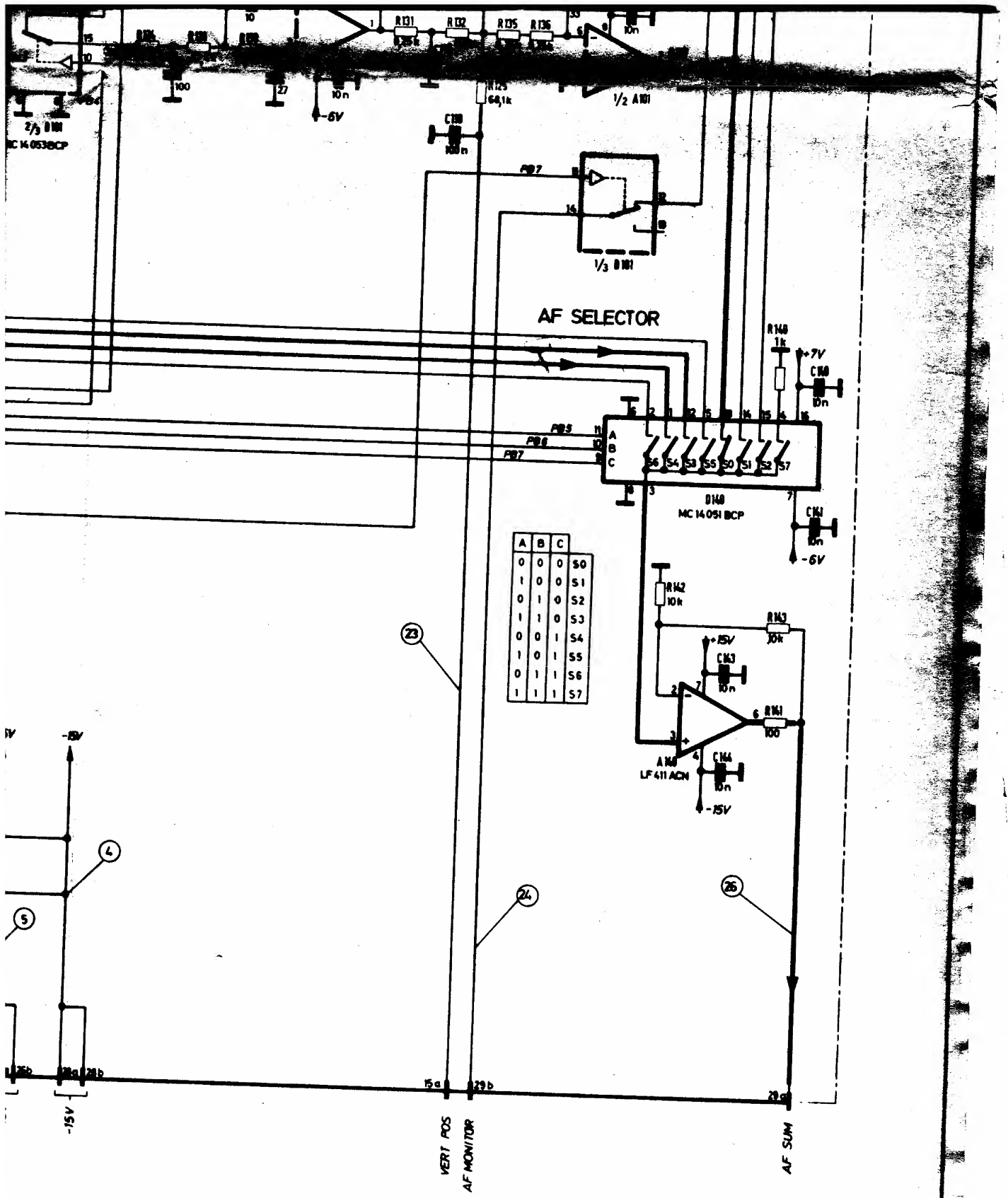

VERT POS  
AF MONITOR

AF SUM

86	Kr.
un	Name
7	NAM1

Schlumberger Meßgeräte GmbH  
 Industriestraße 1  
 4000 Düsseldorf 1

# AF DETECTOR

209 031 S

Typ 4031

834 912 (10x)

834 901 (8x)

834 900 (2x)

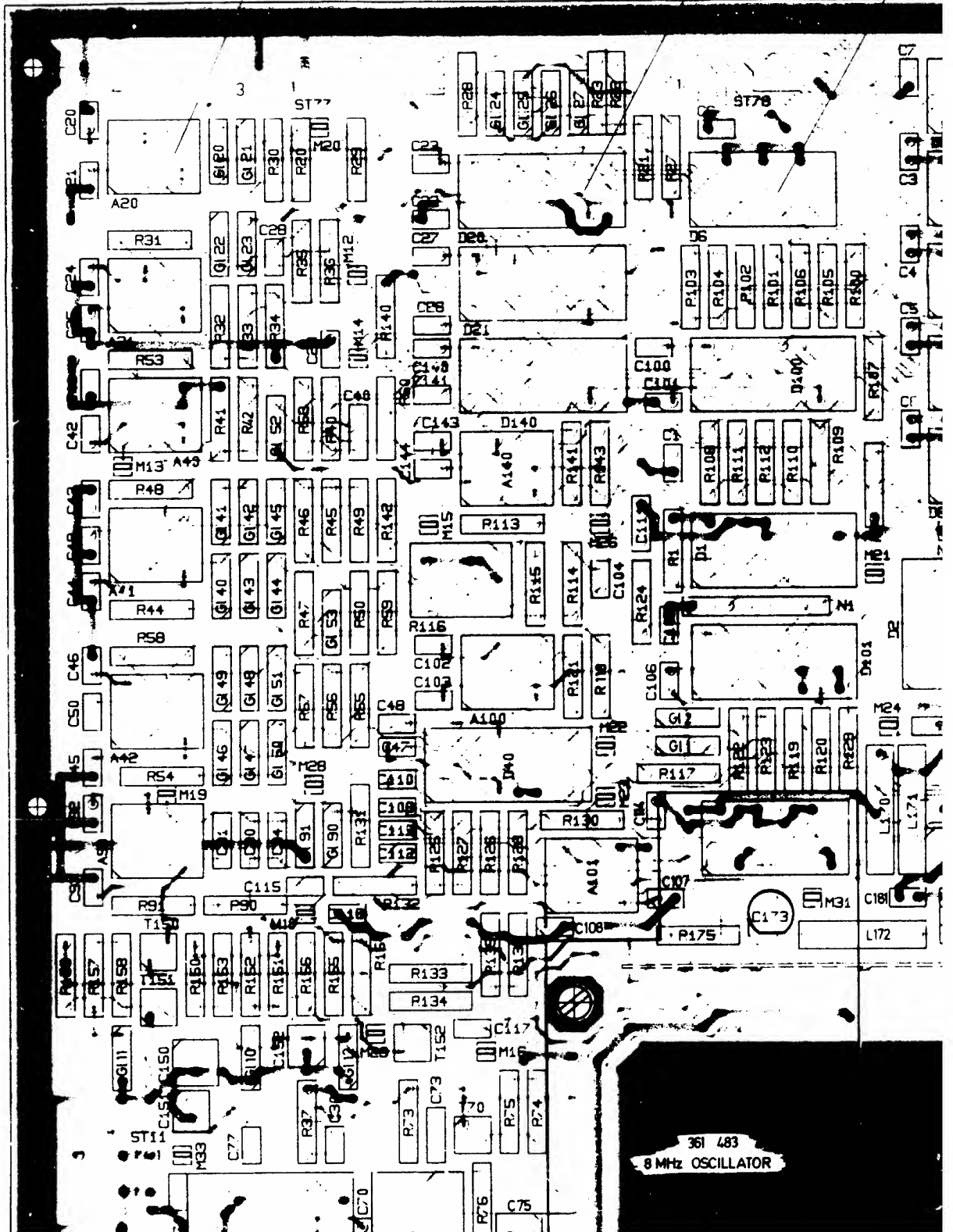

901 (8x)

834 900 (2x)

834 917 (5x)

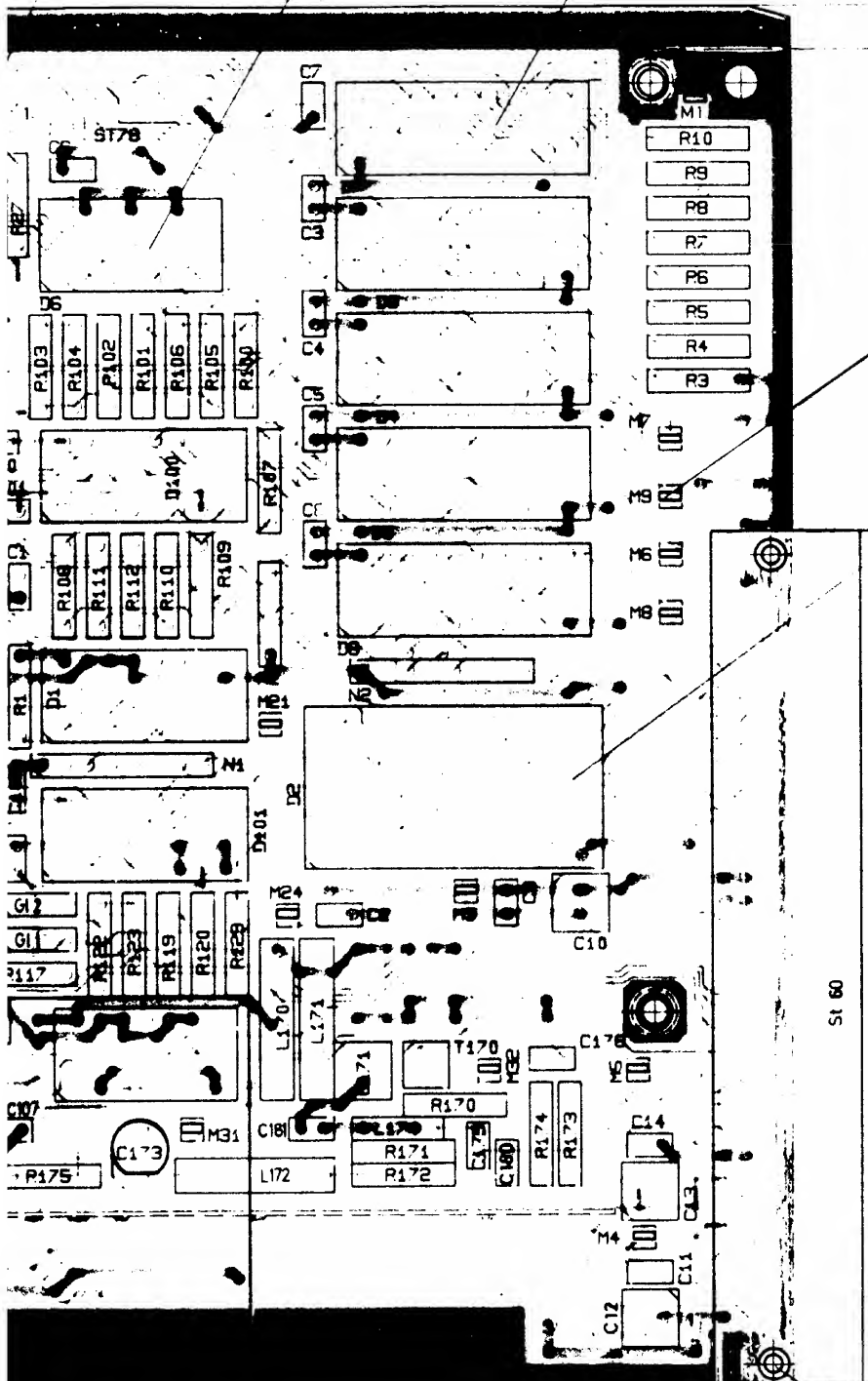

766 009 (27x)

834 913

864 500  
mit Schutzkappe 864 500  
abgedeckt

St 60

361 483  
MHz OSCILLATOR

A2.5x03x9 DIN 7340  
706 329 (2x)

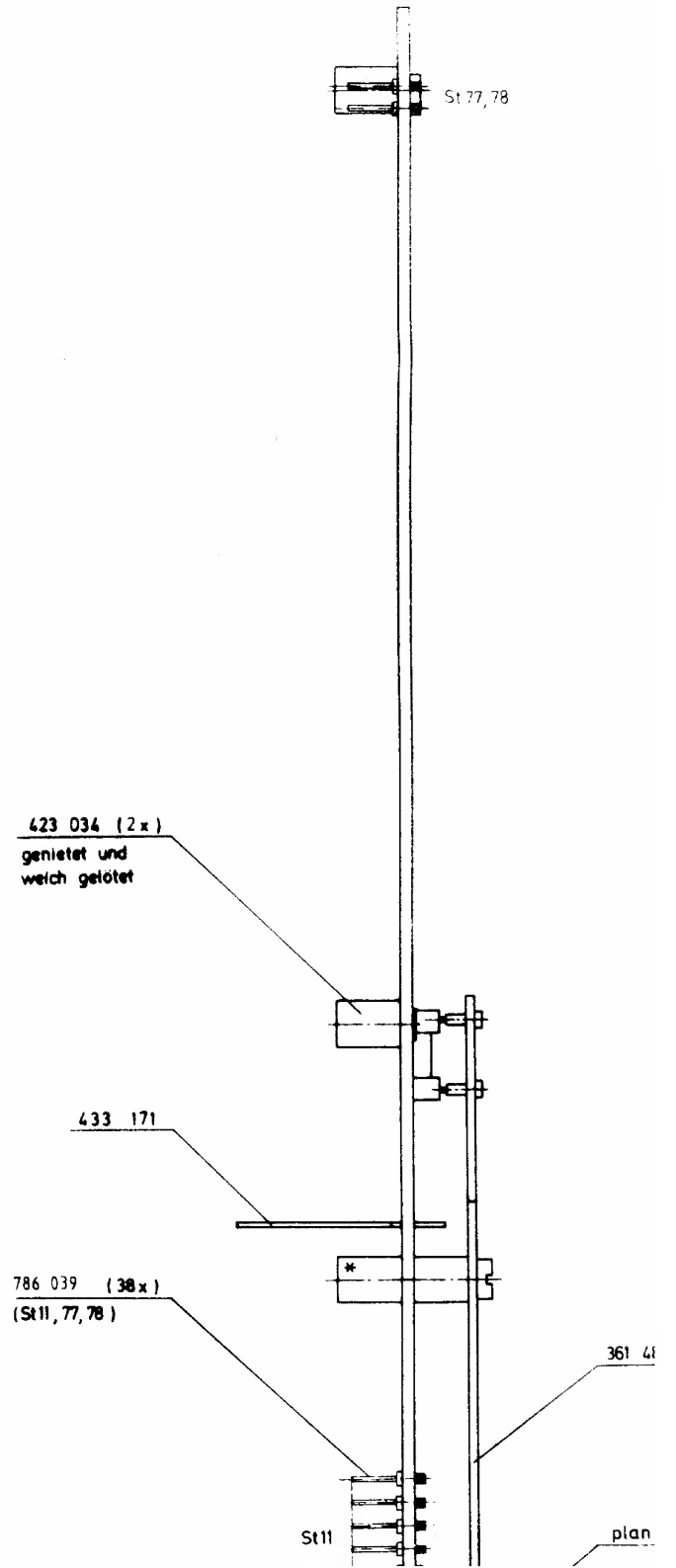
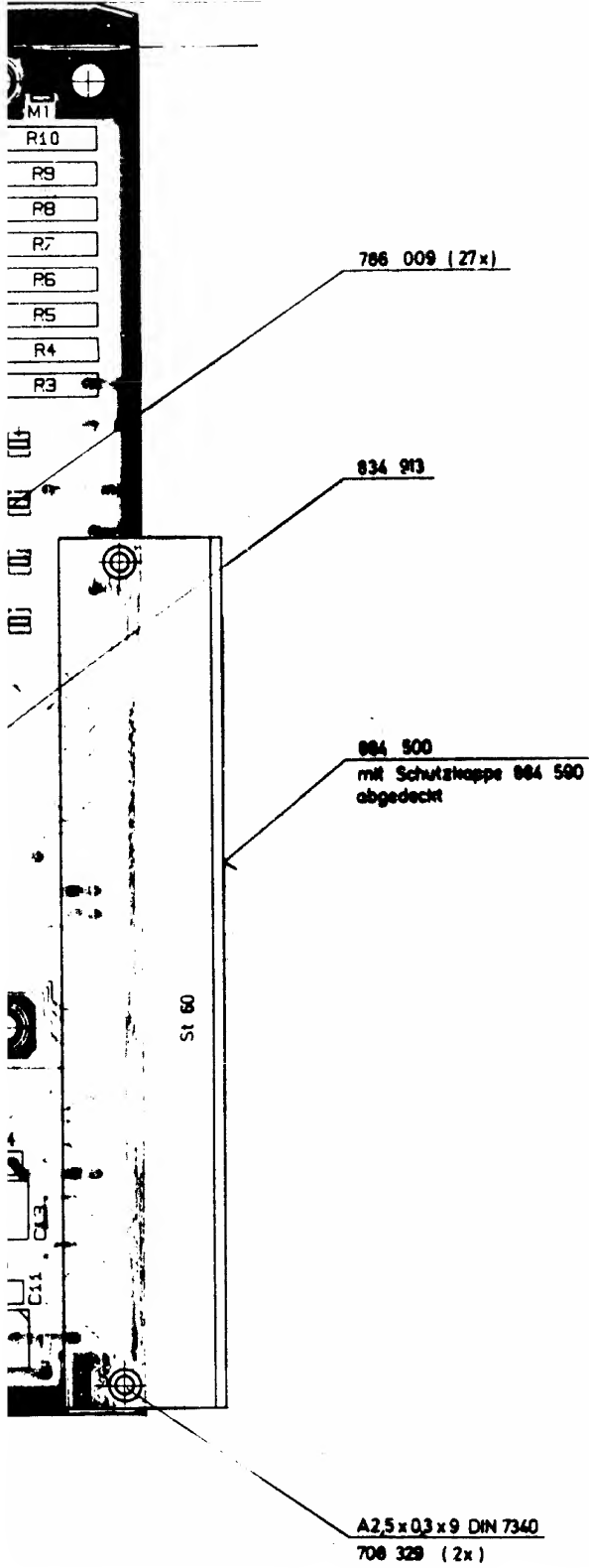

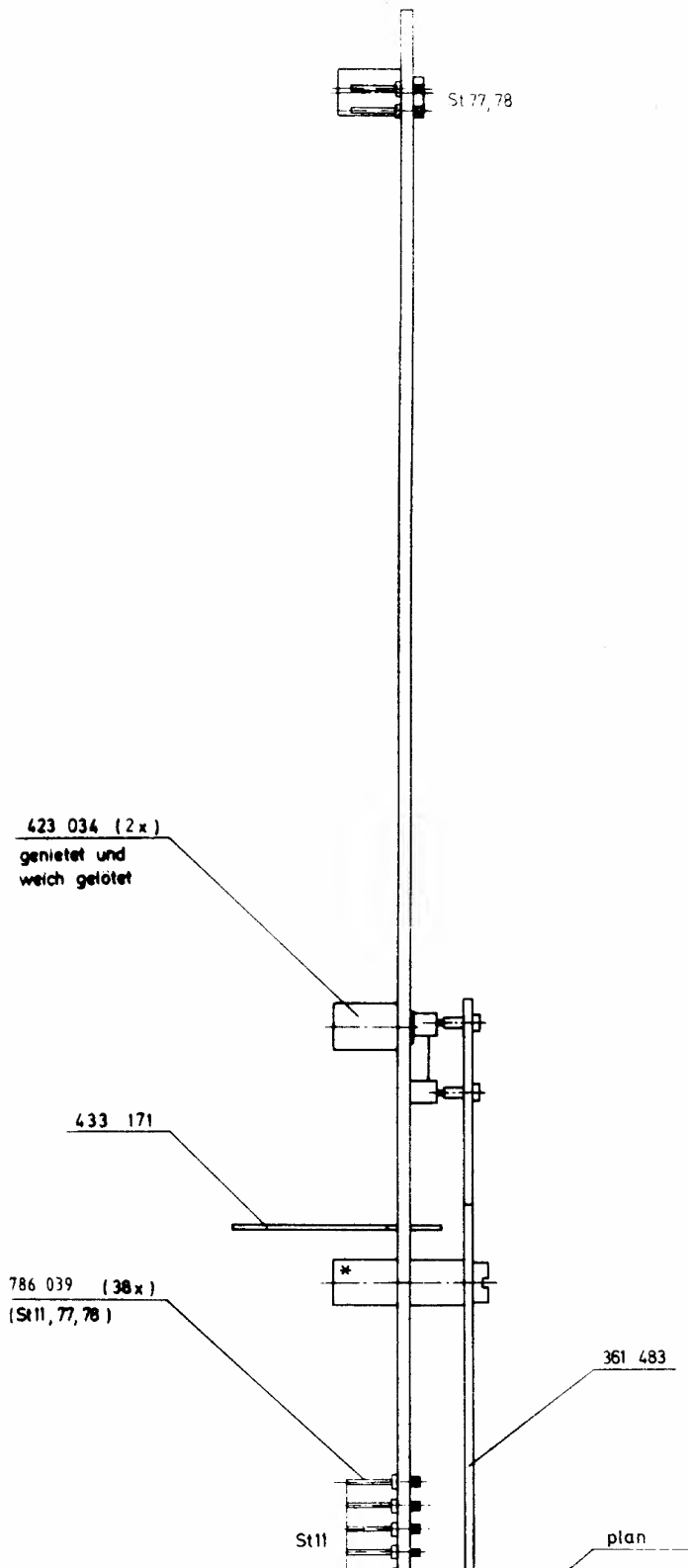

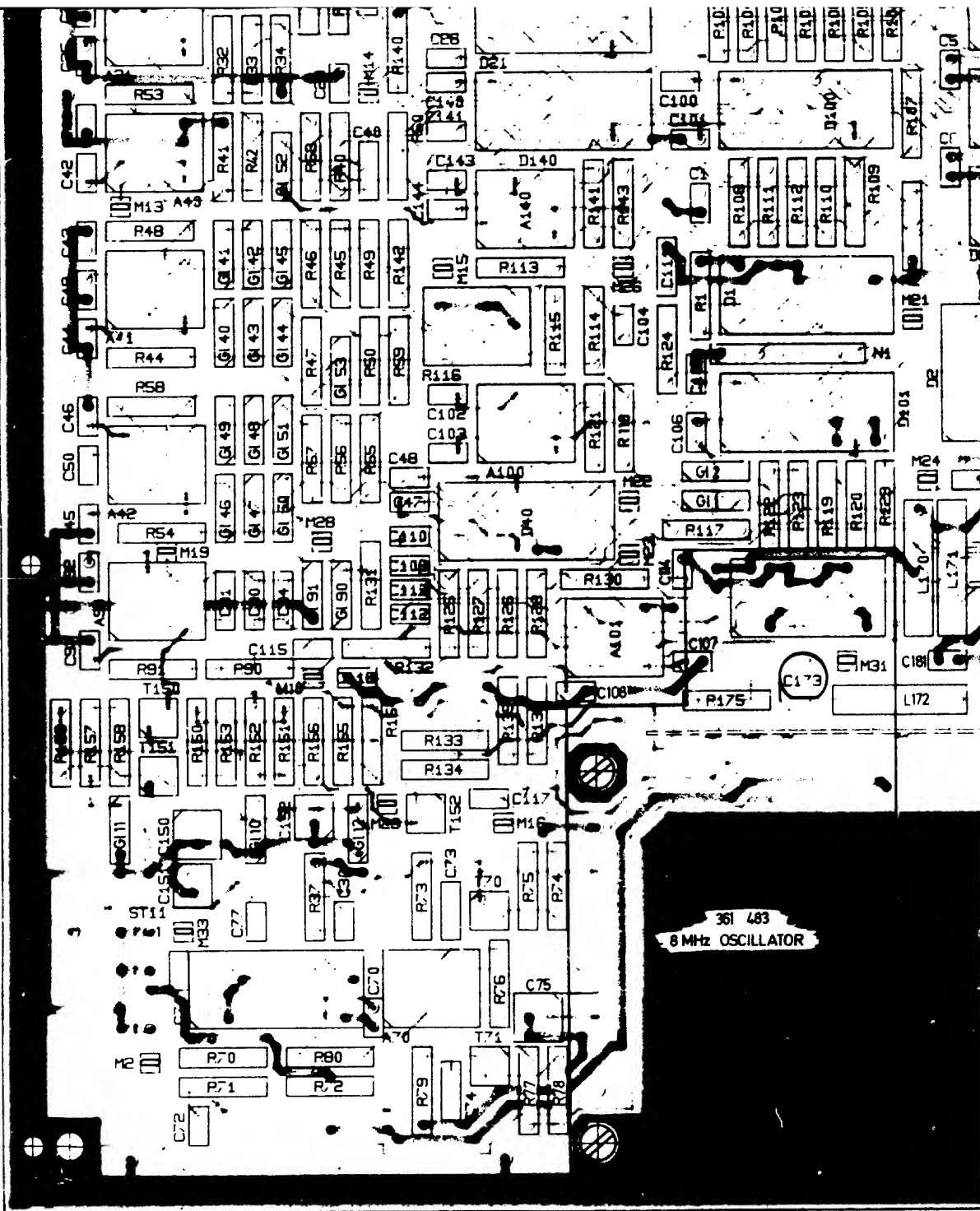

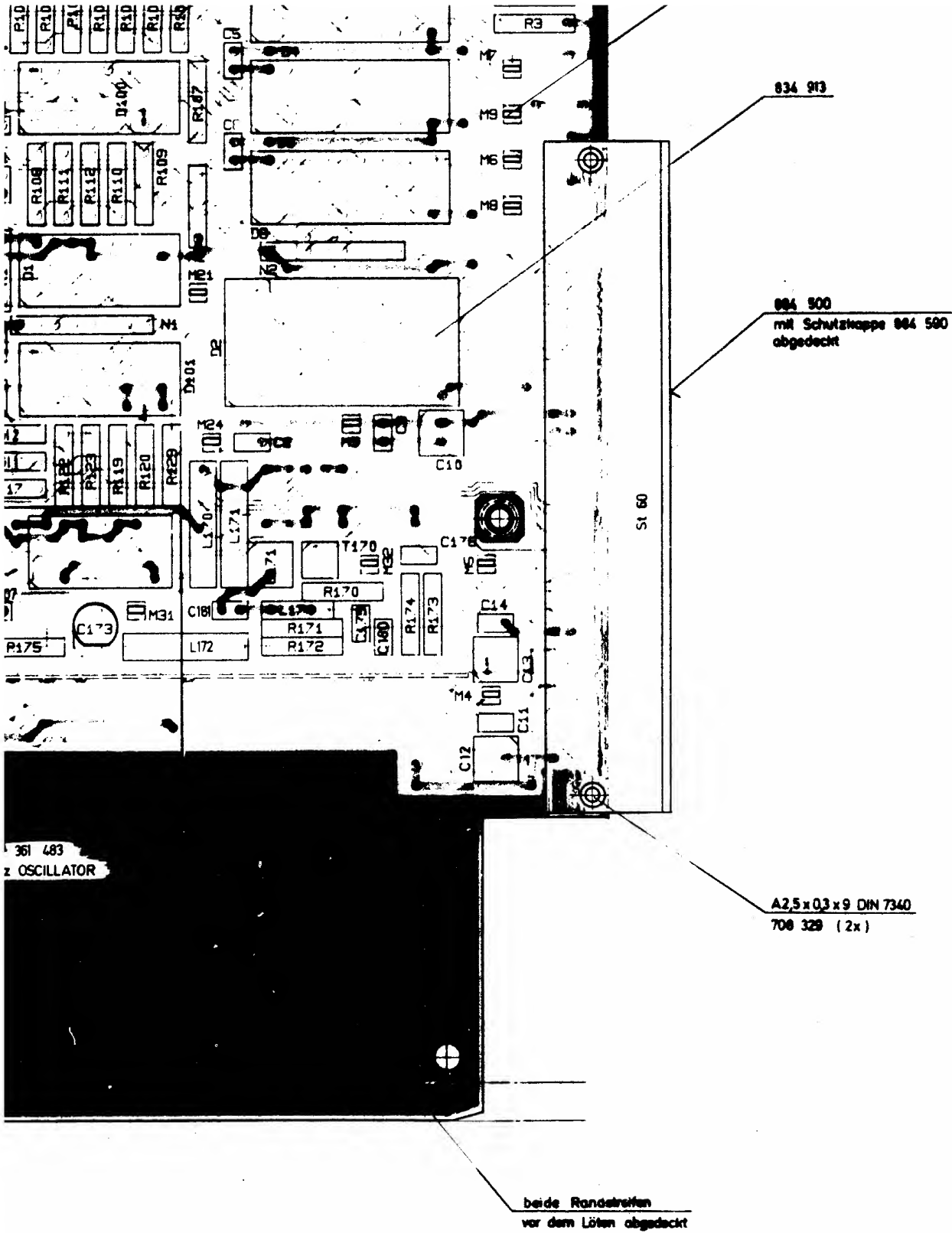

verwendet in:

Gerät:



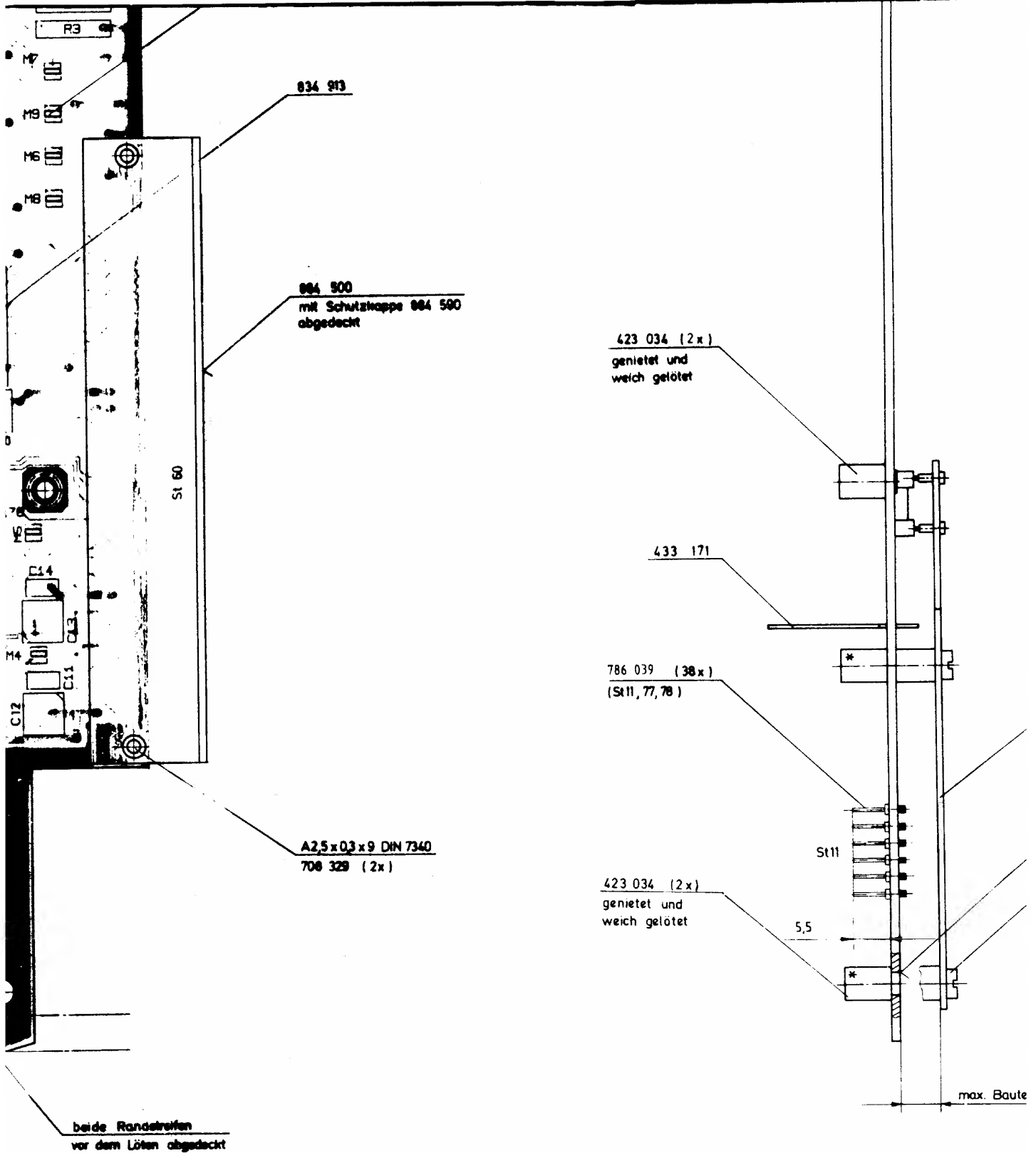

beide Randstreifen  
vor dem Löten abgedeckt

10		
09		
08	3088.84	6.10.81
07		
06		
05		
04		
03		
02		
01		
Rev.	Änderung	Datum

verwendet in:

Gerät:

Diese Zeichnung

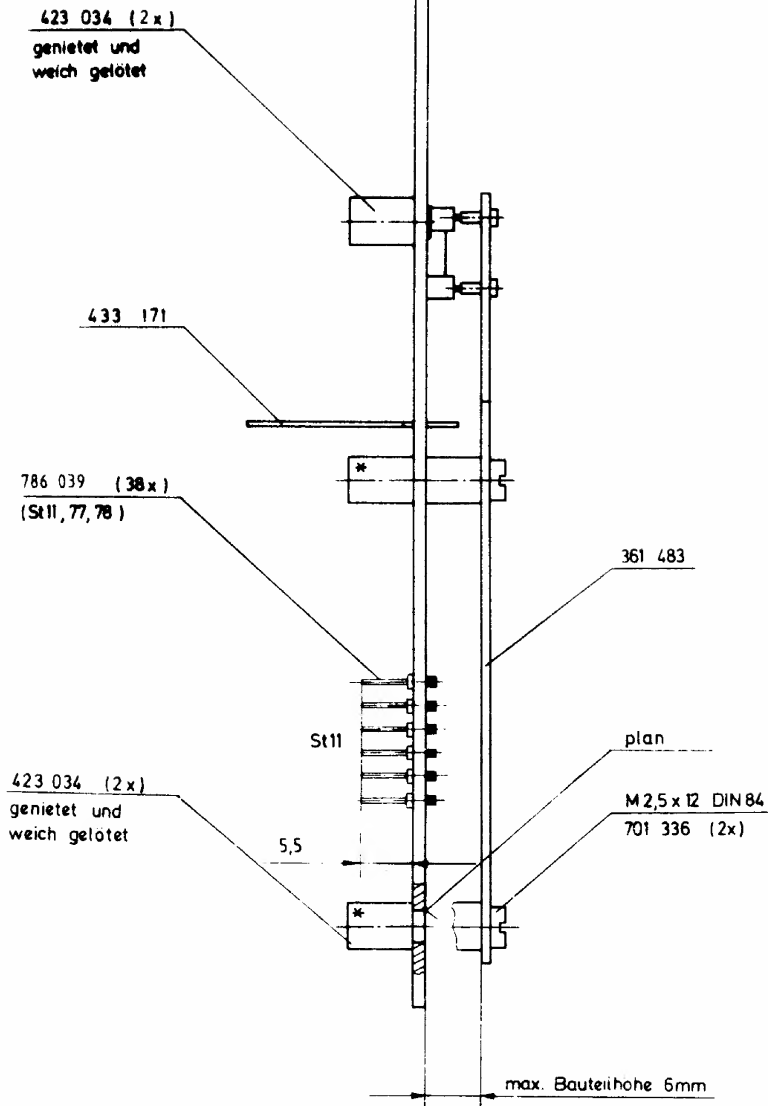

10				Revisions				Schlumberger Meßgeräte GmbH Ingoletcher Straße 67 a 8000 München 46
08	8088184	6.10.88	Kr.					
07				Werkstatt				361 407
06								
05								
04								
03								
02								
01								
Aut. gezeichnet	Angew. gefertigt	Datum	Name					

786 009 (11x)

884 688  
 2x M25 x6 DIN 7985  
 701 654  
 M2.5 DIN 934  
 704 108

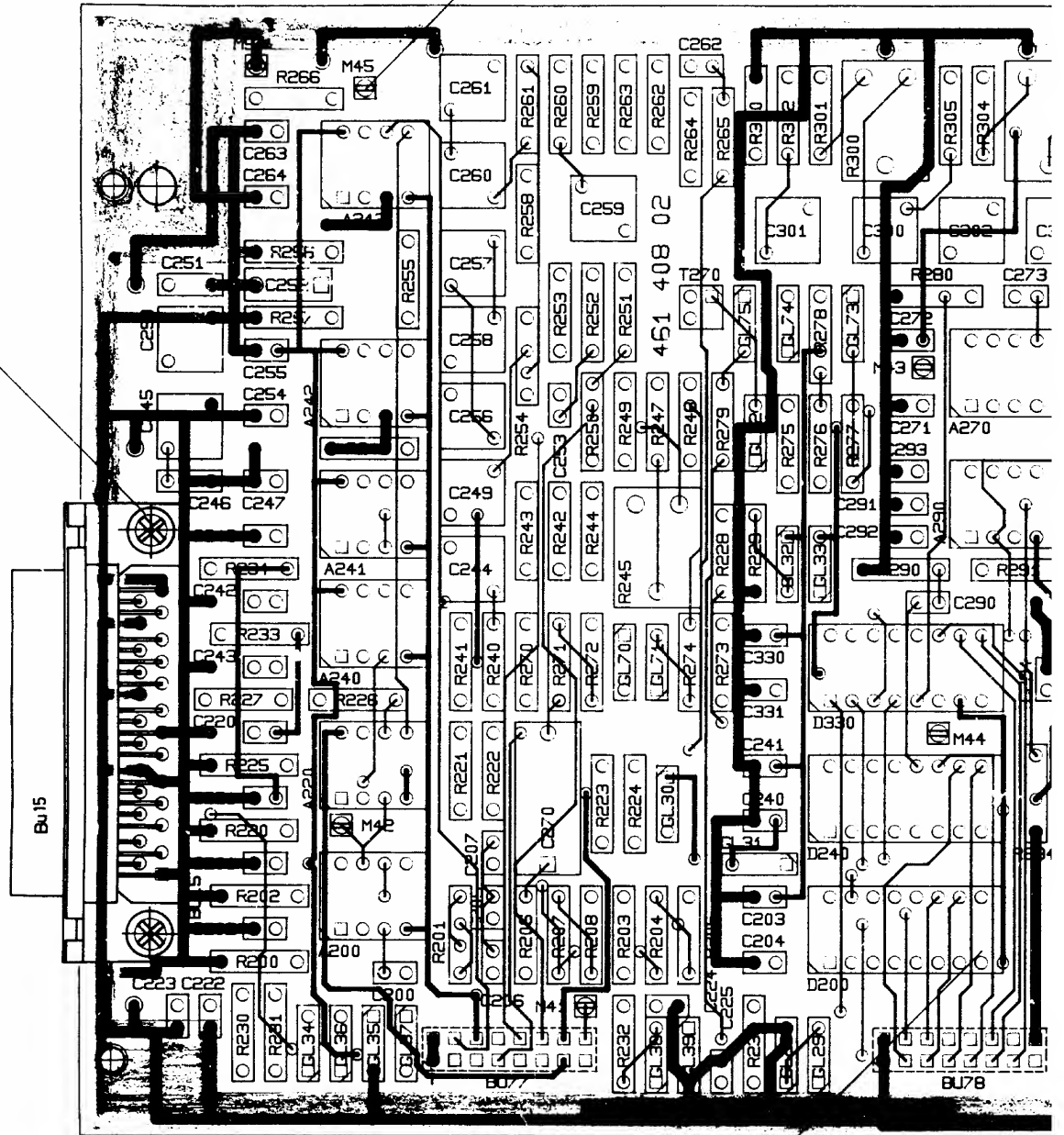

834 901(3x)





1	2	3	4	5	6	7	8
Pos. REF. NO.	Wert VALUE	Bezeichnung Schlumberger PART. NO.	Hersteller MANUFACT	Pos. REF. NO.	Wert VALUE	Bezeichnung Schlumberger PART. NO.	Hersteller MANUFACT
1	Bestückte Leiterplatte PRINTED CIRCUIT BOARD	361 407	SCHL				
	hierzu see	361 407 Sa	SCHL				
1	Bestückte Leiterplatte PRINTED CIRCUIT BOARD	361 408	SCHL				
	hierzu see	361 408 Sa	SCHL				
Bu 12	BNC 50 Ω 35/548	886 263	TELE				
Bu 13	BNC 50 Ω 35/548	886 263	TELE				

07				Schlumberger Meßgeräte GmbH Ingoistädter Straße 67 a 8000 München 46			Schaltteilliste EL. PARTS LIST		Liste besteht LIST CONSISTS aus OF 1 Blatt SHEETS
06									
05				1987	Tag DATE	Name NAME	Bezeichnung Schlumberger PART. NO.		Blatt Nr. SHEET NO.  1
04				gesch.	26.10.87	Dietrich	209 031 Sa		
03							Hierzu Schaltplan SEE CIRCUIT DIAGRAM		
02							209 031 S		
01							Gerät: 4031		
Ausgabe ISSUE	Änd.-Mittig. Nr. MODIFIC. NO.	Tag DATE	Name NAME	bearb. gepr.					
	7088,154	26.10.87	Di						

Diese Zeichnung ist unser Eigentum. Vervielfältigung, unbefugte Verwertung, Mitteilung an andere ist strafbar und schadenersatzpflichtig.



1	2	3	4	5	6	7	8
Pos. REF. NO	Wert VALUE	Bezeichnung Schlumberger PART. NO.	Hersteller MANUFACT	Pos. REF. NO.	Wert VALUE	Bezeichnung Schlumberger PART. NO.	Hersteller MANUFACT
C 1	10 nF ± 10 % 50 V-	813 115	RÖD	C 28	100 nF ± 10 % 50 V-	813 121	RÖD
C 2	10 nF ± 10 % 50 V-	813 115	RÖD	C 29	100 nF ± 10 % 50 V-	813 121	RÖD
C 3	10 nF ± 10 % 50 V-	813 115	RÖD	C 30	100 nF ± 10 % 50 V-	813 121	RÖD
C 4	10 nF ± 10 % 50 V-	813 115	RÖD				
C 5	10 nF ± 10 % 50 V-	813 115	RÖD				
C 6	10 nF ± 10 % 50 V-	813 115	RÖD				
C 7	10 nF ± 10 % 50 V-	813 115	RÖD				
C 8	10 nF ± 10 % 50 V-	813 115	RÖD				
C 9	10 nF ± 10 % 50 V-	813 115	RÖD				
C 10	100 nF ± 20 % 6,3 V-	814 079	MATSO				
C 11	10 nF ± 10 % 50 V-	813 115	RÖD	C 40	156 nF ± 2 % 63 V-	800 999	STET
C 12	22 nF ± 20 % 25 V-	814 077	MATSO	C 41	10 nF ± 10 % 50 V-	813 115	RÖD
C 13	22 nF ± 20 % 25 V-	814 077	MATSO	C 42	10 nF ± 10 % 50 V-	813 115	RÖD
C 14	10 nF ± 10 % 50 V-	813 115	RÖD	C 43	10 nF ± 10 % 50 V-	813 115	RÖD
				C 44	10 nF ± 10 % 50 V-	813 115	RÖD
				C 45	10 nF ± 10 % 50 V-	813 115	RÖD
				C 46	10 nF ± 10 % 50 V-	813 115	RÖD
				C 47	10 nF ± 10 % 50 V-	813 115	RÖD
				C 48	10 nF ± 10 % 50 V-	813 115	RÖD
C 20	10 nF ± 10 % 50 V-	813 115	RÖD	C 49	22 nF ± 15 % 63 V-	802 1366	SIE
C 21	10 nF ± 10 % 50 V-	813 115	RÖD	C 50	22 nF ± 15 % 63 V-	802 1366	SIE
C 22	10 nF ± 10 % 50 V-	813 115	RÖD				
C 23	10 nF ± 10 % 50 V-	813 115	RÖD				
C 24	10 nF ± 10 % 50 V-	813 115	RÖD				
C 25	10 nF ± 10 % 50 V-	813 115	RÖD				
C 26	10 nF ± 10 % 50 V-	813 115	RÖD				
C 27	10 nF ± 10 % 50 V-	813 115	RÖD				

07									
08									
09									
10									
11									
12									
13									
14									
15									
16									
17									
18									
19									
20									
21									
22									
23									
24									
25									
26									
27									
28									
29									
30									
31									
32									
33									
34									
35									
36									
37									
38									
39									
40									
41									
42									
43									
44									
45									
46									
47									
48									
49									
50									
51									
52									
53									
54									
55									
56									
57									
58									
59									
60									
61									
62									
63									
64									
65									
66									
67									
68									
69									
70									
71									
72									
73									
74									
75									
76									
77									
78									
79									
80									
81									
82									
83									
84									
85									
86									
87									
88									
89									
90									
91									
92									
93									
94									
95									
96									
97									
98									
99									
100									

Alle Zeichnungen für diese Anlagen, Vervielfältigung, unbefugte Vervielfältigung, Mitteilung an andere ist strafbar und schadenersatzpflichtig.





1	2	3	4	5	6	7	8
Pos REF NO	Wert VALUE	Bezeichnung Schlumberger PART NO	Hersteller MANUFACT	Pos REF NO	Wert VALUE	Bezeichnung Schlumberger PART NO	Hersteller MANUFACT
C 143	10 nF $\pm$ 10 % 50 V-	813 115	RÖD				
C 144	10 nF $\pm$ 10 % 50 V-	813 115	RÖD	C 178	330 pF $\pm$ 5 % 50 V-	813 060	SIE
				C 179	470 pF $\pm$ 5 % 50 V-	813 062	SIE
				C 180	560 pF $\pm$ 5 % 50 V-	813 063	SIE
				C 181	4,7 nF $\pm$ 5 % 50 V-	813 074	SIE
C 150	47 $\mu$ F $\pm$ 20 % 16 V-	814 078	MATSU				
C 151	10 $\mu$ F $\pm$ 20 % 25 V-	814 076	MATSU				
C 152	10 $\mu$ F $\pm$ 20 % 25 V-	814 076	MATSU				
				D 1	SN 74 LS 139 N	834 688	TEX
				D 2	MC 14 514 BCP	834 426	MOT
				D 3	PC 74 HCT 373 P	834 465	VAL
				D 4	PC 74 HCT 373 P	834 465	VAL
				D 5	PC 74 HCT 373 P	834 465	VAL
				D 6	PC 74 HCT 04 P	834 454	VAL
				D 7	PC 74 HCT 245 P	834 463	VAL
				D 8	PC 74 HCT 373 P	834 465	VAL
C 171	22 $\mu$ F $\pm$ 20 % 25 V-	814 077	MATSU				
C 173	2,7...10 pF 100 V-	817 047	STET				

07				Schlumberger Meßgeräte GmbH Ingoistädter Straße 67a 8000 München 46			Schaltteilliste EL. PARTS LIST		Liste besteht LIST CONSISTS aus OF 10 Blatt SHEETS Blatt Nr SHEET NO		
06			Benennung DESCRIPTION							Bestückte Leiterplatte Typ: AF-SELECTOR / AF-DETECTOR	
05							Bezeichnung Schlumberger PART. NO			361 407 Sa	
04							Herzu Schaltplan SEE CIRCUIT DIAGRAM			209 031 S	
03	8088,184	6.10.88	Kr.	1986	Tag DATE	Name NAME	geschw	11.7.86	Dietrich		
02	8088,151	23.9.88	Kr.	bearb			gepr				
01	8088,11	2.2.88	Kr.								
-	88,70	9.12.86	Kr.								
Ausgabe ISSUE	Änd-Nr. MODIFC. NO.	Tag DATE	Name NAME						Gepr: 4031		

Alle Rechte vorbehalten. Nachdruck, Vervielfältigung und Verbreitung, auch auszugsweise, ist ohne schriftliche Genehmigung der Schlumberger Meßgeräte GmbH.

1	2	3	4	5	6	7	8
Pos REF NO	Wert VALUE	Bezeichnung Schlumberger PART NO	Hersteller MANUFACT	Pos REF NO	Wert VALUE	Bezeichnung Schlumberger PART NO	Hersteller MANUFACT
				D 140	MC 14 051 BCP	834 481	MOT
D 20	MC 140 53 BCP	834 391	M.				
D 21	MC 140 53 BCP	834 391	MOT				
				G1 1	BAT 85	830 499	VAL
				G1 2	BAT 85	830 499	VAL
D 40	DG 201 CJ	834 413	SILI	G1 10	ZPD 6,8	830 442	ITT
				G1 11	ZPD 8,2	830 444	ITT
				G1 12	ZPD 7,5	830 445	ITT
D 70	MC 140 53 BCP	834 391	MOT	G1 20	BAT 85	830 499	VAL
				G1 21	BAT 85	830 499	VAL
				G1 22	BAT 85	830 499	VAL
				G1 23	BAT 85	830 499	VAL
				G1 24	BAT 85	830 499	VAL
				G1 25	BAT 85	830 499	VAL
D 100	MC 140 51 BCP	834 481	MOT	G1 26	HP 2800	830 500	HP
D 101	MC 140 53 BCP	834 391	MOT	G1 27	HP 2800	830 500	HP

07				Schlumberger Meßgeräte GmbH Ingolstädter Straße 67 a 8000 München 46			Schaltteilliste EL. PARTS LIST		Liste besteht LIST CONSISTS		
08			Benennung DESCRIPTION							Bestückte Leiterplatte Typ: AF-SELECTOR/ AF-DETECTOR	
09	8088.11	2.2.88	Kr.				Bezeichnung Schlumberger PART NO		361 407 Sa		Blatt Nr SHEET NO
08	7088.76	26.6.87	D1				1986	Tag DATE	Name NAME	Hierzu Schaltplan SEE CIRCUIT DIAGRAM	
01	7088.6A	18.5.87	D1	geschr	11.7.86	Dietrich	209 031 S		5		
-	6088.70	9.12.86	Kr.	beord			Gerät: 4031				
Ausgabe ISSUE	Änd.-Nr. MODIF. NO.	Tag DATE	Name NAME	gepr							

Diese Zeichnung ist unser Eigentum. Verweigerung unbefugte Verwendung, Mitteilung an andere, Erstellen und Schadenersatzpflichten.

1	2	3	4	5	6	7	8
Pos REF NO	Wert VALUE	Bezeichnung Schlumberger PART NO.	Hersteller MANUFACT	Pos REF NO	Wert VALUE	Bezeichnung Schlumberger PART NO	Hersteller MANUFACT
G1 40							
G1 41							
G1 42							
G1 43							
G1 44							
G1 45							
G1 46	1 N 4148	830 240	ITT				
G1 47							
G1 48							
G1 49							
G1 50							
G1 51							
G1 52	HP 2800	830 500	HP				
G1 53	HP 2800	830 500	HP	L 170	100 $\mu$ H $\pm$ 5 %	821 030	DALE
				L 171	100 $\mu$ H $\pm$ 5 %	821 030	DALE
				L 172	68 $\mu$ H $\pm$ 5 %	821 028	DALE
G1 90	HP 2800	830 500	HP	L 174	1,5 $\mu$ H $\pm$ 10 %	821 124	DALE
G1 91	HP 2800	830 500	HP				
				N 1	Netzwerk 7x100 k $\Omega$	804 512	DALE
				N 2	Netzwerk 7x100 k $\Omega$	804 512	DALE

07				Schlumberger Meßgeräte GmbH Ingotstädter Straße 67 a 8000 München 48			Schaltteilliste EL. PARTS LIST Benennung DESCRIPTION Bestückte Leiterplatte Typ: AF-SELECTOR/ AF-DETECTOR		Liste besteht LIST CONSISTS OF 10 SHEET SHEETS
08									
04	8088,184	6.10.88	Kr.						SHEET NO. 6
09	8088,151	23.9.88	Kr.						
02	8088,76	24.6.87	Di	1986	Tag DATE	Name NAME	Bezeichnung Schlumberger PART NO	361 407 Sa	
01	8088,64	18.5.87	Di	11.7.86	DiETRICH		Name Schaltplan SSE CIRCUIT DIAGRAM	209 031 S	
	8088,72	9.12.86	Kr.				Größe:	4031	
An- gabe SERIE	Art-Nr. NO.	Tag DATE	Name NAME	beab. dpr					

1	2	3	4	5	6	7	8
Pos. REF NO	Wert VALUE	Bezeichnung Schlumberger PART NO.	Hersteller MANUFACT	Pos. REF NO	Wert VALUE	Bezeichnung Schlumberger PART NO.	Hersteller MANUFACT
				R 27	2,21 kΩ ± 1%	802 041	RÖD
R 1	4,75 kΩ ± 1%	802 045	RÖD	R 28	2,21 kΩ ± 1%	802 041	RÖD
R 2	100 kΩ ± 1%	802 061	RÖD	R 29	10 kΩ ± 1%	802 049	RÖD
R 3	100 kΩ ± 1%	802 061	RÖD	R 30	1 kΩ ± 1%	802 037	RÖD
R 4	100 kΩ ± 1%	802 061	RÖD	R 31	3,32 kΩ ± 1%	802 043	RÖD
R 5	100 kΩ ± 1%	802 061	RÖD	R 32	39,2 kΩ ± 1%	802 056	RÖD
R 6	10 kΩ ± 1%	802 049	RÖD	R 33	825 Ω ± 1%	802 036	RÖD
R 7	10 kΩ ± 1%	802 049	RÖD	R 34	10 kΩ ± 1%	802 049	RÖD
R 8	10 kΩ ± 1%	802 049	RÖD	R 35	100 kΩ ± 1%	802 041	RÖD
R 9	10 kΩ ± 1%	802 049	RÖD	R 36	47,5 kΩ ± 1%	802 037	RÖD
R 10	10 kΩ ± 1%	802 049	RÖD	R 37	150 kΩ ± 1%	802 063	RÖD
				R 40	22,1 kΩ ± 1%	802 053	RÖD
				R 41	10 kΩ ± 1%	802 049	RÖD
				R 42	10 kΩ ± 1%	802 049	RÖD
				R 44	100 Ω ± 1%	802 025	RÖD
				R 45	10 kΩ ± 1%	802 049	RÖD
				R 46	100 kΩ ± 1%	802 061	RÖD
R 20	100 Ω ± 1%	802 025	RÖD	R 47	1 kΩ ± 1%	802 037	RÖD
R 21	1,02 kΩ ± 1%	802 040	RÖD	R 48	100 Ω ± 1%	802 025	RÖD
R 22	2,21 kΩ ± 1%	802 041	RÖD	R 49	10 kΩ ± 1%	802 049	RÖD
R 23	33,2 kΩ ± 1%	802 055	RÖD	R 50	10 kΩ ± 1%	802 049	RÖD
			RÖD				
			RÖD	R 52	10 kΩ ± 1%	802 049	RÖD

07				Schlumberger Meßgeräte GmbH Ingolettkircher Straße 67 a 8000 München 46			Schaltteilliste EL. PARTS LIST Bestückte Leiterplatte Typ: AF-SELECTOR/ AF-DETECTOR		Liste besteht LIST CONSISTS	
08			aus OF							
09			Blatt SHEETS							
01	7088.123	28.8.87	No.						Blatt Nr. SHEET NO	
	6088.70	9.11.86	Sei	7						
02				1986	Tag DATE	Name NAME	Bezeichnung Schlumberger PART NO		361 407 Sa	
03				gepr.	11.7.86	Dietrich	Hierzu Schaltung SEE CIRCUIT DIAGRAM		209 031 S	
04				bearb.			Gedr.: 8033			
05				gpr.						

Copyright 1986 Schlumberger Messtechnik GmbH. Alle Rechte vorbehalten. Nachdruck, Vervielfältigung und Verbreitung, auch auszugsweise, ist ohne schriftliche Genehmigung der Schlumberger Messtechnik GmbH.



1	2	3	4	5	6	7	8
Pos. REF. NO	Wert VALUE	Bezeichnung Schumberger PART NO.	Hersteller MANUFACT	Pos. REF. NO	Wert VALUE	Bezeichnung Schumberger PART NO.	Hersteller MANUFACT
R 117	12,1 kΩ ± 1%	802 050	RÖD				
R 118	56,2 kΩ ± 1%	802 058	RÖD	R 150	1,21 kΩ ± 1%	802 038	RÖD
R 119	10 kΩ ± 1%	802 049	RÖD	R 151	47,5 Ω ± 1%	802 021	RÖD
R 120	15 kΩ ± 1%	802 051	RÖD	R 152	47,5 Ω ± 1%	802 021	RÖD
R 121	100 kΩ ± 1%	802 061	RÖD	R 153	1 kΩ ± 1%	802 037	RÖD
R 122	0 Ω	805 050	POLY	R 154	1,82 kΩ ± 1%	802 040	RÖD
R 123	15 kΩ ± 1%	802 051	RÖD	R 155	47,5 Ω ± 1%	802 021	RÖD
R 124	15 kΩ ± 1%	802 051	RÖD	R 156	47,5 Ω ± 1%	802 021	RÖD
R 125	68,1 kΩ ± 1%	802 059	RÖD	R 157	5,62 kΩ ± 1%	802 046	RÖD
R 126	22,1 kΩ ± 1%	802 053	RÖD	R 158	825 Ω ± 1%	802 036	RÖD
R 127	182 kΩ ± 1%	802 064	RÖD	R 159	6,81 kΩ ± 1%	802 047	RÖD
R 128	27,4 kΩ ± 1%	802 054	RÖD				
R 129	100 Ω ± 1%	802 025	RÖD				
R 130	27,4 kΩ ± 1%	802 054	RÖD				
R 131	8,25 kΩ ± 1%	802 048	RÖD				
R 132	8,25 kΩ ± 1%	802 048	RÖD				
R 133	8,25 kΩ ± 1%	802 048	RÖD				
R 134	8,25 kΩ ± 1%	802 048	RÖD				
R 135	8,25 kΩ ± 1%	802 048	RÖD				
R 136	8,25 kΩ ± 1%	802 048	RÖD				
				R 170	1,5 kΩ ± 1%	802 039	RÖD
				R 171	5,62 kΩ ± 1%	802 046	RÖD
R 140	1 kΩ ± 1%	802 037	RÖD	R 172	10 kΩ ± 1%	802 049	RÖD
R 141	100 Ω ± 1%	802 025	RÖD	R 173	1 kΩ ± 1%	802 037	RÖD
R 142	10 kΩ ± 1%	802 049	RÖD	R 174	1 kΩ ± 1%	802 037	RÖD
R 143	10 kΩ ± 1%	802 049	RÖD	R 175	150 Ω ± 1%	802 027	RÖD

07				Schumberger Meßgeräte GmbH Ingotenstraße 67a 8000 München 40			Schaltteilliste EL. PARTS LIST		Liste besteht LIST CONSISTS aus OF 10 Blatt SHEETS
08									
09				Bestückte Leiterplatte Typ: AF-SELECTOR/ AF-DETECTOR			301 407 Sa		Blatt Nr. SHEET NO. 19
04	8088-184	6.10.88	Kr.						
05				301 407 S			209 031 S		
06									
01			Di	1987	Tag DATE	Name NAME	301 407 S		
				19.5.87	Dieterich		301 407 S		
							301 407 S		

Diese Zeichnung ist unser Eigentum. Vervielfältigung, unbefugte Verwertung, Mitteilung an andere ist strafbar und schadenersatzpflichtig.

1	2	3	4	5	6	7	8
Pos. REF. NO.	Wert VALUE	Bezeichnung Schlumberger PART NO.	Hersteller MANUFACT.	Pos. REF. NO.	Wert VALUE	Bezeichnung Schlumberger PART NO.	Hersteller MANUFACT.
St 11	1-937906-A (6x)	884 790	AMP				
				T 170	BC 550 B	832 127	SIE
St 60	Stecker 64 pol.	884 500	SIE				
St 77	1-937906-A (16x)	884 790	AMP				
St 78	1-937906-A (16x)	884 790	AMP				
T 70	BC 560 B	832 128	SIE				
T 71	BC 550 B	832 127	SIE				
T 150	BC 550 B	832 127	SIE				
T 151	BC 550 B	832 127	SIE				
T 152	BC 560 B	832 128	SIE				

07				Schlumberger Meßgeräte GmbH Ingoletztcher Straße 67 a 8000 München 48			Schaltteilliste EL. PARTS LIST Bestückte Leiterplatte Typ: AF-SELECTOR/ AF-DETECTOR		Bestimmung DESCRIPTION	Liste besteht LIST CONSISTS aus OF 10 Blatt SHEETS	
08											
06											
04											
02				1986	Tag DATE	Name NAME	Bezeichnung Schlumberger PART. NO.	361 407 Sa	Blatt Nr. SHEET NO. 10		
01				gezeichnet DRAWN	11.7.86	Rietrich	Werte Schaltplan SEE CIRCUIT DIAGRAM	209 031 S			
-	6088.70	9.12.86	geprüft CHECKED				Bezeichnung NAME	4031			

Diese Zeichnung ist unser Eigentum. Verleumdung, unbefugte Vervielfältigung, Verbreitung an andere ist strafbar und schadenersatzpflichtig.



1	2	3	4	5	6	7	8
Pos. REF. NO.	Wert VALUE	Bezeichnung Schlumberger PART. NO.	Hersteller MANUFACT.	Pos. REF. NO.	Wert VALUE	Bezeichnung Schlumberger PART. NO.	Hersteller MANUFACT.
A 200	TLC 272 AC P	834 217	TEX				
A 220	µA 772 TC	834 081	FAIR				
A 240	TLC 272 ACP	834 217	TEX	C 200	22 nF ± 10 % 50 V-	813 117	RÖD
A 241	TLC 272 ACP	834 217	TEX	C 201	10 nF ± 10 % 50 V-	813 115	RÖD
A 242	TLC 272 ACP	834 217	TEX	C 202	10 nF ± 10 % 50 V-	813 115	RÖD
A 243	TLC 272 ACP	834 217	TEX	C 203	10 nF ± 10 % 50 V-	813 115	RÖD
				C 204	10 nF ± 10 % 50 V-	813 115	RÖD
A 270	TLC 272 ACP	834 217	TEX	C 205	2,2 pF ± 2 % 63 V-	810 555	STET
				C 206	22 pF ± 2 % 63 V-	810 509	STET
A 290	LM 311 N - 8	834 017	NS	C 207	22 pF ± 2 % 63 V-	810 509	STET
A 300	TLC 272 ACP	834 217	TEX	C 220	10 nF ± 10 % 50 V-	813 115	RÖD
				C 221	10 nF ± 10 % 50 V-	813 115	RÖD
A 330	µA 772 TC	834 081	FAIR	C 222	180 pF ± 5 % 50 V-	813 057	SIE
A 331	AD 536 AJH	834 135	ANA	C 223	180 pF ± 5 % 50 V-	813 057	SIE
A 332	AD 536 AJH	834 135	ANA	C 224	180 pF ± 5 % 50 V-	813 057	SIE
				C 225	180 pF ± 5 % 50 V-	813 057	SIE
				C 240	10 nF ± 10 % 50 V-	813 115	RÖD
				C 241	10 nF ± 10 % 50 V-	813 115	RÖD
				C 242	10 nF ± 10 % 50 V-	813 115	RÖD
Bu 15	D-Buchse 25 pol.	884 688	AMP	C 243	10 nF ± 10 % 50 V-	813 115	RÖD
				C 244	6,8 nF ± 1 % 63 V-	812 177	SIE
Bu 77	Buchse 16 pol.	884 711	AMP	C 245	3,9 nF ± 1 % 63 V-	812 174	SIE
Bu 78	Buchse 16 pol.	884 711	AMP	C 246	100 pF ± 2 % 63 V-	810 534	STET

07				Schlumberger Meßgeräte GmbH Ingolstädter Straße 67a 8000 München 46			Schaltteilliste EL. PARTS LIST Benennung DESCRIPTION Bestückte Letterplatte Typ: AF-METER		Liste besteht LIST CONSISTS aus OF 6 Blatt SHEETS			
06												
05							1986	Tag DATE	Name NAME	Bezeichnung Schlumberger PART. NO.	361 408 Sa	Blatt Nr. SHEET NO. 1
04							gesch.	9.7.86	Dietrich	Herz. Schaltplan SEE CIRCUIT DIAGRAM	209 031 S / 209 034 S	
03				bearb.		<i>LA</i>	Geprüft: 4031					
02				ISSUE								
01	8088.202	27.10.84	Kr.									
	6088.70	7.12.86	LA									

Diese Zeichnung ist unser Eigentum. Vervielfältigung, unbefugte Verwendung, Mitteilung an andere ist strafbar und schadenersatzpflichtig.



1	2	3	4	5	6	7	8
Pos. REF. NO.	Wert VALUE	Bezeichnung Schlumberger PART. NO.	Hersteller MANUFACT	Pos. REF. NO.	Wert VALUE	Bezeichnung Schlumberger PART. NO.	Hersteller MANUFACT
C 311	4,7 nF ± 5 % 50 V-	813 074	SIE	D 200	MC 140 53 BCP	834 391	MOT
				D 240	MC 140 53 BCP	834 391	MOT
C 330	10 nF ± 10 % 50 V-	813 115	RÖD	D 330	MC 140 53 BCP	834 391	MOT
C 331	10 nF ± 10 % 50 V-	813 115	RÖD				
C 332	10 nF ± 10 % 50 V-	813 115	RÖD				
C 333	10 nF ± 10 % 50 V-	813 115	RÖD	G1 28	BAT 85	830 499	VAL
C 334	1 µF ± 10 % 63 V-	812 348	RÖD	G1 29	1 N 4148	830 240	ITT
C 335	22 µF ± 20 % 25 V-	814 077	MATSU	G1 30	BAT 85	830 499	VAL
C 336	0,47 µF ± 10 % 63 V-	812 345	RÖD	G1 31	BAT 85	830 499	VAL
C 337	0,47 µF ± 10 % 63 V-	812 345	RÖD	G1 32	BAT 85	830 499	VAL
C 338	0,47 µF ± 10 % 63 V-	812 345	RÖD	G1 33	BAT 85	830 499	VAL
C 339	22 µF ± 20 % 25 V-	814 077	MATSU	G1 34	1 N 4148	830 240	ITT
C 340	22 µF ± 20 % 25 V-	814 077	MATSU	G1 35	BAT 85	830 499	VAL
C 341	0,47 µF ± 10 % 63 V-	812 345	RÖD	G1 36	1 N 4148	830 240	ITT
C 342	22 µF ± 20 % 25 V-	814 077	MATSU	G1 37	BAT 85	830 499	VAL
C 343	1 µF ± 10 % 63 V-	812 348	RÖD	G1 38	1 N 4148	830 240	ITT
C 344	0,47 µF ± 10 % 63 V-	812 345	RÖD	G1 39	BAT 85	830 499	VAL
C 345	0,47 µF ± 10 % 63 V-	812 345	RÖD				

07												
06												
05												
04												
03												
02	8088,202	27.10.86	Kr.									
01	7088,64	18.5.87	Di	1986	Tag DATE	Name NAME	Schlumberger Meßgeräte GmbH Ingolstädter Straße 67 a 8000 München 46		Schaltteilliste EL. PARTS LIST		Liste besteht LIST CONSISTS	
-	6088,70	6.12.86	Ye	geoch.	9.7.86	Dietrich	Bestückte Leiterplatte Typ: AF-METER		Beschreibung DESCRIPTION		aus OF	6
				bearb.			361 408 Sa		Bezeichnung Schlumberger PART. NO.		Blatt SHEETS	
Ausgabe ISSUE	Änd.-Mittg. MODIFIC. NO.	Tag DATE	Name NAME	gepr.			Hierzu Schaltplan 209 031 S / 209 034 S SEE CIRCUIT DIAGRAM		Gerät: 4031		Blatt Nr. SHEET NO.	3

Diese Zeichnung ist unser Eigentum. Vervielfältigung, unbefugte Verwertung, Mitteilung an andere ist strafbar und schadenersatzpflichtig.



1	2		3		4	5		6		7		8
Pos. REF. NO	Wert VALUE		Bezeichnung Schlumberger PART. NO.		Hersteller MANUFACT	Pos. REF. NO	Wert VALUE		Bezeichnung Schlumberger PART. NO.		Hersteller MANUFACT	
R 251	274	$\Omega \pm 1\%$	802	030	RÖD	R 278	100	$k\Omega \pm 1\%$	802	061	RÖD	
R 252	5,62	$k\Omega \pm 1\%$	802	046	RÖD	R 279	22,1	$k\Omega \pm 1\%$	802	053	RÖD	
R 253	5,62	$k\Omega \pm 1\%$	802	046	RÖD	R 280	2,21	$k\Omega \pm 1\%$	802	041	RÖD	
R 254	274	$\Omega \pm 1\%$	802	030	RÖD							
R 255	150	$k\Omega \pm 1\%$	802	063	RÖD							
R 256	6,81	$k\Omega \pm 1\%$	802	047	RÖD							
R 257	56,2	$k\Omega \pm 1\%$	802	058	RÖD							
R 258	10	$k\Omega \pm 1\%$	802	049	RÖD							
R 259	1,21	$k\Omega \pm 1\%$	802	038	RÖD							
R 260	39,2	$k\Omega \pm 1\%$	802	056	RÖD							
R 261	150	$k\Omega \pm 1\%$	802	063	RÖD							
R 262	681	$\Omega \pm 1\%$	802	035	RÖD							
R 263	10	$\Omega \pm 1\%$	802	013	RÖD	R 290	100	$k\Omega \pm 1\%$	802	061	RÖD	
R 264	221	$k\Omega \pm 1\%$	802	065	RÖD	R 291	33,2	$k\Omega \pm 1\%$	802	055	RÖD	
R 265	1	$M\Omega \pm 1\%$	802	073	RÖD	R 292	6,81	$k\Omega \pm 1\%$	802	047	RÖD	
R 266	100	$\Omega \pm 1\%$	802	025	RÖD	R 293	274	$k\Omega \pm 1\%$	802	066	RÖD	
						R 294	475	$\Omega \pm 1\%$	802	033	RÖD	
						R 295	10	$k\Omega \pm 1\%$	802	049	RÖD	
						R 296	10	$k\Omega \pm 1\%$	802	049	RÖD	
R 270	47,5	$k\Omega \pm 1\%$	802	057	RÖD	R 297	4,75	$k\Omega \pm 1\%$	802	045	RÖD	
R 271	47,5	$k\Omega \pm 1\%$	802	057	RÖD	R 298	221	$\Omega \pm 1\%$	802	029	RÖD	
R 272	47,5	$k\Omega \pm 1\%$	802	057	RÖD							
R 273	47,5	$k\Omega \pm 1\%$	802	057	RÖD	R 300	10	$k\Omega \pm 10\%$	807	506	ALLEN	
R 274	47,5	$k\Omega \pm 1\%$	802	057	RÖD	R 301	4,75	$k\Omega \pm 1\%$	802	045	RÖD	
R 275	47,5	$k\Omega \pm 1\%$	802	057	RÖD	R 302	150	$k\Omega \pm 1\%$	802	063	RÖD	
R 276	47,5	$k\Omega \pm 1\%$	802	057	RÖD	R 303	4,7	$k\Omega \pm 10\%$	807	505	ALLEN	
R 277	100	$\Omega \pm 1\%$	802	025	RÖD	R 304	68,1	$k\Omega \pm 1\%$	802	059	RÖD	

07					Schlumberger Meßgeräte GmbH Ingolstädter Straße 67 a 8000 München 46			Schaltteilliste EL. PARTS LIST Bestückte Leiterplatte Typ: AF-METER			Liste besteht LIST CONSISTS aus OF 6 Blatt SHEETS	
06												
05												
04												
03												
02												
01	8088.202	27.10.88	Kr.	1986	Tag DATE	Name NAME	Bezeichnung Schlumberger PART. NO.	361 408 Sa		Blatt Nr. SHEET NO. 5		
-	6088.70	1.12.86	Rg	geachr.	9.7.86	Dietrich						
Ausgabe ISSUE	Änd.-Antrag Nr. MODIFIC. NO.	Tag DATE	Name NAME	bearb. BY			Hierzu Schaltplan SEE CIRCUIT DIAGRAM	209 031 S / 209 034 S				
				gepr.			Gerät:	4031				

Diese Zeichnung ist unser Eigentum. Vervielfältigung, unbefugte Verwertung, Mitteilung an andere ist strafbar und schadenersatzpflichtig.

1	2	3	4	5	6	7	8
Pos. REF. NO	Wert VALUE	Bezeichnung Schlumberger PART. NO.	Hersteller MANUFACT	Pos. REF. NO	Wert VALUE	Bezeichnung Schlumberger PART NO	Hersteller MANUFACT
R 305	8,25 kΩ ± 1 %	802 048	RÖD	R 332	10 kΩ ± 1 %	802 049	RÖD
R 306	150 kΩ ± 1 %	802 063	RÖD	R 333	18,2 kΩ ± 1 %	802 052	RÖD
R 307	4,75 kΩ ± 1 %	802 045	RÖD	R 334	47,5 kΩ ± 1 %	802 057	RÖD
R 308	10 kΩ ± 10 %	807 506	ALLEN	R 335	1 kΩ ± 1 %	802 037	RÖD
R 309	121 Ω ± 1 %	802 026	RÖD	R 336	4,75 kΩ ± 1 %	802 045	RÖD
R 310	1,82 kΩ ± 1 %	802 040	RÖD	R 337	22,1 kΩ ± 1 %	802 053	RÖD
R 311	100 Ω ± 1 %	802 025	RÖD	R 338	10 Ω ± 1 %	802 013	RÖD
R 312	10 kΩ ± 10 %	807 506	ALLEN	R 339	10 Ω ± 1 %	802 013	RÖD
R 313	0 Ω	805 050	POLY	R 340	10 kΩ ± 1 %	802 049	RÖD
R 314	150 kΩ ± 1 %	802 063	RÖD	R 341	22,1 kΩ ± 1 %	802 053	RÖD
R 315	4,7 kΩ ± 10 %	807 505	ALLEN	R 342	39,2 kΩ ± 1 %	802 056	RÖD
R 316	68,1 kΩ ± 1 %	802 059	RÖD	R 343	10 kΩ ± 1 %	802 049	RÖD
R 317	8,25 kΩ ± 1 %	802 048	RÖD	R 344	221 kΩ ± 1 %	802 065	RÖD
R 318	150 kΩ ± 1 %	802 063	RÖD	R 345	392 kΩ ± 1 %	802 068	RÖD
R 319	4,75 kΩ ± 1 %	802 045	RÖD	R 346	10 Ω ± 1 %	802 013	RÖD
R 320	10 kΩ ± 10 %	807 506	ALLEN	R 347	10 Ω ± 1 %	802 013	RÖD
R 321	121 Ω ± 1 %	802 026	RÖD	R 348	22,1 kΩ ± 1 %	802 053	RÖD
R 322	1,82 kΩ ± 1 %	802 040	RÖD	R 349	4,75 kΩ ± 1 %	802 045	RÖD
R 323	100 Ω ± 1 %	802 025	RÖD				
R 324	100 kΩ ± 1 %	802 061	RÖD				
R 325	1,5 kΩ ± 1 %	802 039	RÖD				
R 326	100 kΩ ± 1 %	802 061	RÖD	T 270	BC 550 B	832 127	SIE
R 327	1,5 kΩ ± 1 %	802 039	RÖD				
R 330	4,75 kΩ ± 1 %	802 045	RÖD	T 290	BC 550 B	832 127	SIE
R 331	33,2 kΩ ± 1 %	802 055	RÖD				

07				Schlumberger Meßgeräte GmbH Ingolstädter Straße 67a 8000 München 46			Schaltteilliste EL. PARTS LIST		Liste besteht LIST CONSISTS	
08			Benennung DESCRIPTION						Bestückte Leiterplatte Typ: AF-METER	aus OF
06			Bezeichnung Schlumberger PART NO.				361 408 Sa	Blatt SHEETS		
04			Hierzu Schaltplan SEE CIRCUIT DIAGRAM				209 031 S / 209 034 S	Blatt Nr SHEET NO	6	
03			Ausgabe ISSUE			Gerät: 4031				
02	8088.202	27.10.88	Kr.	1986	Tag DATE	Name NAME				
01	7088.64	18.5.87	Di	geschw.	9.7.86	Dietrich				
	6088.70	9.12.86	Gr	bearb.						
				gepr.						

Diese Zeichnung ist unser Eigentum. Vervielfältigung, unbefugte Verwertung, Mitteilen an andere ist strafbar und schadenersatzpflichtig.

1	2	3	4	5	6	7	8
Pos. REF. NO.	Wert VALUE	Bezeichnung Schlumberger PART. NO.	Hersteller MANUFACT	Pos. REF. NO.	Wert VALUE	Bezeichnung Schlumberger PART. NO.	Hersteller MANUFACT
C1	4,7 nF $\pm$ 5% 50 V-	813 074	SIE				
C2	4,7 nF $\pm$ 5% 50 V-	813 074	SIE				
C3	100 pF $\pm$ 2% 63 V-	810 534	STET				
D1	SN 74 ALS 86 N	834 419	TEX				
D2	SN 74 LS 290 N	834 678	TEX				
L1	100 $\mu$ H $\pm$ 5%	821 030	DALE				
L2	3,9 $\mu$ H $\pm$ 10%	821 013	DALE				
R1	150 $\Omega$ $\pm$ 1%	802 027	RÖD				

07				Schlumberger Meßgeräte GmbH Ingolstädter Straße 67 a 8000 München 46			<b>Schaltteilliste</b> EL. PARTS LIST		Liste besteht LIST CONSISTS aus OF 1 Blatt SHEETS
06									
05				1988	Tag DATE	Name NAME	Bezeichnung Schlumberger PART. NO.	361 483 Sa 301 483 Sa	
04				geachr.	2.2.88	Kr.	Hierzu Schaltplan SEE CIRCUIT DIAGRAM	209 031 S	
03				bearb.		<i>Kr.</i>	Gerät:	6031	
02				gepr.					
01									
	8088 11	2.2.88	Kr.						
	Änd.-Mittg. Nr.	Tag DATE	Name NAME						

Diese Zeichnung ist unser Eigentum. Vervielfältigung, unbefugte Verwertung, Mitteilung an andere ist strafbar und schadenersatzpflichtig.

### 10-MHz Reference Crystal

The 10-MHz reference crystal is decisive for the long-term accuracy of the internally produced RF signals. Therefore an oven keeps the crystal at a constant temperature. The thermistor R3 is part of a resistor bridge whose filament voltage controls with the control amplifier A1 the filament current through the power transistor T2. The temperature of the oven is set to 73 °C with resistor R7.

The transistor T3 and the 10-MHz crystal make up the oscillator. With varactor G12 and potentiometer R15 the frequency is set roughly. For fine frequency setting and correction of aging use potentiometer R20, which can be reached from outside the module.

Via the buffers T4 and D1 the 10-MHz signal is distributed internally to socket Bu13 (rear panel) and socket Bu11. External synchronizing of the oscillator can be made by rear-panel socket Bu12 and the following amplifier T5.

Ref.No. 214 031 F	Sub 10-MHz Reference Crystal	Date
Type 4031	Unit	Sheet 1/1
Schlumberger		Functional Description





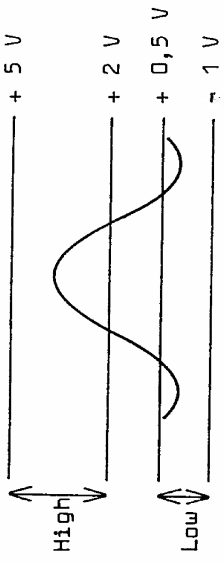

Necessary Equipment	Measuring Procedure	Measuring Point	Frequency	Adjustment	Set Value	Actual Value																		
DVM  Frequency counter	<p>2) <u>Frequency setting</u></p> <p>2.1 <u>Basic setting</u></p> <p>Coarse setting</p> <p>Fine setting</p> <p>2.2 <u>Frequency range</u></p> <p>R<sub>coarse</sub> (R15) on righthand stop</p> <p>R<sub>coarse</sub> (R15) on lefthand stop</p> <p>If a limit is not reached, alter C17</p> <p>1 pF alteration in capacitance corresponds to approx. 10 Hz alteration in frequency</p> <p>If frequency is too low, reduce C17, and vice versa</p> <p>Only use capacitors with Schlumberger nos. 810 629 through 810 635</p> <p>Set R<sub>coarse</sub></p> <p>Replace styropore insulation</p>	<p>Mp5 Mp6</p> <p>Bu13 Bu13</p> <p>Bu13</p>		<p>R15 R20</p> <p>R15 R15</p> <p>R15</p>	<p>+7.00 V +6.20 V</p> <p>10 MHz +/- 10 Hz 10 MHz -&gt; 40 Hz</p> <p>10 MHz +/- 5 Hz</p>																			
<table border="1"> <tr> <td>Issue</td> <td>Alteration No.</td> <td>Date</td> <td>Name</td> </tr> <tr> <td></td> <td></td> <td></td> <td></td> </tr> <tr> <td></td> <td></td> <td></td> <td></td> </tr> </table>		Issue	Alteration No.	Date	Name									<table border="1"> <tr> <td>Ref. No.</td> <td>214 031 A</td> </tr> <tr> <td>Type</td> <td>STABILLOCK 4031</td> </tr> </table>	Ref. No.	214 031 A	Type	STABILLOCK 4031	<table border="1"> <tr> <td>Sub Unit</td> <td>10-MHz Reference Crystal</td> </tr> </table>	Sub Unit	10-MHz Reference Crystal	<table border="1"> <tr> <td>Sheet</td> <td>3/6</td> </tr> </table>	Sheet	3/6
Issue	Alteration No.	Date	Name																					
Ref. No.	214 031 A																							
Type	STABILLOCK 4031																							
Sub Unit	10-MHz Reference Crystal																							
Sheet	3/6																							

Schlumberger		Adjustment and Test Procedure										Sheet						
Necessary Equipment	Measuring Procedure	Measuring Point	Frequency	Adjustment	Set Value	Actual Value	Issue	Name	Date	Alteration No.	Issue	Name	Date	Alteration No.	Ref. No.	Sub Unit	Sheet	
							Alteration No.	Alteration No.	Alteration No.	Alteration No.	Alteration No.	Alteration No.	Alteration No.	Alteration No.	Alteration No.	Alteration No.	Alteration No.	Alteration No.
Oscilloscope	<p>3) <u>Oscillator level</u> Oscilloscope, DC-coupled Low level High level</p> 	Mp3 Mp3			+0.5 to -1.0 V +2.0 to +5.0 V													
Frequency counter, Generator	<p>4) <u>Ext. synchronization, capture range</u></p> <p>Synchronize counter and 10-MHz generator with one another. Connect counter to Bu13, set R<sub>fine</sub> Set generator to 10 MHz -8 Hz, 0.15 V EMF Connect generator to Bu12 Proceed in same manner with offset 10 MHz +8 Hz Counter resolution &lt; 1 Hz is negligible Counter display <u>must</u> remain stable</p>	Bu13  Bu13 Bu13 Bu13		R20	0.8-2 V <sub>pp</sub>  10 MHz ±1 Hz 10 MHz -8 Hz 10 MHz +8 Hz													
															214 031 A	10-MHz Reference Crystal	4/6	

Schlumberger		Adjustment and Test Procedure										Sheet					
Necessary Equipment	Measuring Procedure	Measuring Point	Frequency	Adjustment	Set Value	Actual Value	Issue	Alteration No.	Date	Name	Issue	Alteration No.	Date	Name	Sub Unit	Type	Sheet
							Alteration No.	Date	Name	Alteration No.	Date	Name	Ref. No.	Type			
Frequency counter	<p>5) <u>Temperature response of oscillator frequency</u> Synchronize counter with stable 10-MHz reference frequency (error &lt; 0.01 Hz) over entire testing time if its stability is inadequate.</p> <p>Oscillator &gt; 2 hrs at +10°C Oscillator &gt; 2 hrs at +60°C</p> <p>Setpoint   <math>f_{10^{\circ}\text{C}} - f_{60^{\circ}\text{C}}   \approx 1.4 \text{ Hz}</math></p> <p>[The temperature test is to be performed in the works]</p>	Bu13 Bu13			Measure $f_{10^{\circ}\text{C}}$ Measure $f_{60^{\circ}\text{C}}$										10-MHz Reference Crystal	STABLOCK 4031	5/6

Schlumberger		Adjustment and Test Procedure										Sheet					
Necessary Equipment	Measuring Procedure	Measuring Point	Frequency	Adjustment	Set Value	Actual Value	Issue	Alteration No.	Date	Name	Issue	Alteration No.	Date	Name	Ref. No.	Sub Unit	Sheet
Frequency counter	<p>6) <u>Coarse frequency setting</u> This adjustment can be made on the oscillator inside the unit at <math>T_{amb}</math> 23 to 27°C, or when it is outside at <math>T_{amb}</math> 33 to 37°C</p> <p>Synchronize counter with standard frequency 10 MHz <math>\pm 0.01</math> Hz Fine setting</p>	Bu13		R20	10 MHz $\pm 0.02$ Hz										214 031 A	10-MHz Reference Crystal	6/6
															STABILOCK 4031		







1	2	3	4	5	6	7	8
Pos. REF. NO.	Wert VALUE	Bezeichnung Schlumberger PART. NO.	Hersteller MANUFACT	Pos. REF. NO.	Wert VALUE	Bezeichnung Schlumberger PART. NO.	Hersteller MANUFACT
1	Bestückte Leiterplatte PRINTED CIRCUIT BOARD	361 419	SCHL				
Bu 12	35/548	in 209 031	SCHL				
Bu 13	35/548	in 209 031	SCHL				

07													
06													
05													
04													
03													
02													
01													
				Schlumberger Meßgeräte GmbH Ingolstädter Straße 67 a 8000 München 46				Schaltteilliste EL. PARTS LIST				Liste besteht LIST CONSISTS	
								Benennung DESCRIPTION				aus OF	
								10 MHz REFERENCE				Blatt SHEETS	
								Bezeichnung Schlumberger PART. NO.				Blatt Nr. SHEET NO.	
								214 031 3a				1	
								Hierzu Schaltplan SEE CIRCUIT DIAGRAM					
								214 031 3					
								Gerät: 4831					
Ausgabe ISSUE		Änd.-Mitg. Nr. MODIFIC. NO.		Tag DATE		Name NAME		gechr. bearb. gepr.		1986 19.9.86		Dietrich Ker	
		6088.22		22.11.86		Ker							

Diese Zeichnung ist unser Eigentum. Vervielfältigung, unbefugte Verwertung, Mitteilung an andere ist strafbar und schadenersatzpflichtig.

1	2	3	4	5	6	7	8
Pos. REF. NO.	Wert VALUE	Bezeichnung Schlumberger PART. NO.	Hersteller MANUFACT.	Pos. REF. NO.	Wert VALUE	Bezeichnung Schlumberger PART. NO.	Hersteller MANUFACT.
A 1	LF 356 N	834 059	NAT	C 21	470 pF $\pm 5\%$ 63 V -	810 530	STET
				C 22	10 nF $\pm 10\%$ 50 V-	813 115	RÖD
				C 23	22 $\mu$ F $\pm 20\%$ 25 V-	814 077	MATSU
Bu 11	826 044 - 6	884 771	AMP	C 24	100 nF $\pm 10\%$ 50 V-	813 121	RÖD
				C 25	10 nF $\pm 10\%$ 50 V-	813 115	RÖD
				C 26	100 nF $\pm 10\%$ 50 V-	813 121	RÖD
				C 27	100 $\mu$ F $\pm 20\%$ 25V -	814 079	MATSU
C 1	10 nF $\pm 10\%$ 50 V-	813 115	RÖD				
C 2	10 nF $\pm 10\%$ 50 V-	813 115	RÖD				
C 3	10 nF $\pm 10\%$ 50 V-	813 115	RÖD	C 30	10 nF $\pm 10\%$ 50 V-	813 115	RÖD
C 4	10 $\mu$ F $\pm 20\%$ 25 V-	814 076	MATSU	C 31	100 $\mu$ F $\pm 20\%$ 25 V-	814 079	MATSU
				C 32	27 pF $\pm 2\%$ 63 V-	810 510	STET
				C 33	10 nF $\pm 10\%$ 50 V-	813 115	RÖD
				C 34	10 nF $\pm 10\%$ 50 V-	813 115	RÖD
				C 35	10 nF $\pm 10\%$ 50 V-	813 115	RÖD
				C 36	220 pF $\pm 5\%$ 50 V-	813 058	VAL
C 10	47 $\mu$ F $\pm 20\%$ 25 V-	814 078	MATSU	C 37	470 pF $\pm 5\%$ 50 V-	813 062	VAL
C 11	100 nF $\pm 10\%$ 50 V-	813 121	RÖD				
C 12	10 nF $\pm 10\%$ 50 V-	813 115	RÖD				
C 13	270 pF $\pm 5\%$ 63 V -	810 532	STET				
C 14	100 pF $\pm 2\%$ 63 V-	810 534	VAL				
C 15	18 pF $\pm 5\%$ 63 V-	810 615	STET	D 1	SN 74 LS 04 N	834 635	TEX
C 16	1 nF $\pm 1\%$ 500 V-	811 135	JAHRE				
C 17	5,6 pF $\pm 0,5\%$ 63 V-	810 631	STET				
				G1 1	1 N 3157	830 412	MOT
C 20	270 pF $\pm 5\%$ 63 V-	810 532	STET	G1 2	88 909 B	1n 300 663	SCNL

07				Schlumberger Meßgeräte GmbH Ingolstädter Straße 67a 8000 München 46				Schaltteilliste EL. PARTS LIST		Liste besteht LIST CONSISTS aus OF 3 Blatt SHEETS
06										
05	8088.143	5.9.88	Lehn	1986	Tag DATE 9.7.86	Name NAME Dietrich	Bezeichnung Schlumberger PART. NO. 361 419 Sa		Blatt Nr. SHEET NO. 1	
04	7088.110	4.8.87	Lei	beob.			Merz Schaltung SEE CIRCUIT DIAGRAM 214 031 S			
03	7088.83	3.7.87	Mo.	bearb.			Gerät: 4031			
02	7088.17	5.2.87	Be.							
01	6088.39	24.10.86	BR							
	6088.21	17.9.86	St.							
Ausgabe ISSUE	Nr. MODIFIC. NO.	Tag DATE	Name NAME							

Diese Zeichnung ist unser Eigentum. Vervielfältigung, unbefugte Verwertung, Mitteilung an andere ist strafbar und schadenersatzpflichtig.

1	2	3	4	5	6	7	8
Pos. REF. NO.	Wert VALUE	Bezeichnung Schlumberger PART. NO.	Hersteller MANUFACT	Pos. REF. NO.	Wert VALUE	Bezeichnung Schlumberger PART. NO.	Hersteller MANUFACT
G1 3	BAT 85	830 499	VAL	R 14	392 Ω ± 1 %	802 032	RÖD
				R 15	2 kΩ ± 10 %	807 673	VIT
				R 16	2,21 kΩ ± 1 %	802 368	RÖD
L 1	10 μH ± 10 %	821 018	GOW				
L 2	1 μH ± 10 %	821 122	GOW				
L 3	10 μH ± 10 %	821 018	GOW				
				R 20	2 kΩ ± 10 %	807 693	BOUR
				R 21	5,62 kΩ ± 1 %	802 046	RÖD
				R 22	10 kΩ ± 1 %	802 376	RÖD
				R 23	10 kΩ ± 1 %	802 376	RÖD
Q 1	10 MHz	(853 032) in 300 663	SCHL	R 24	2,74 kΩ ± 1 %	802 042	RÖD
				R 25	2,74 kΩ ± 1 %	802 369	RÖD
				R 26	10 kΩ ± 1 %	802 376	RÖD
				R 27	100 Ω ± 1 %	802 352	RÖD
R 1	10 kΩ ± 1 %	802 376	RÖD				
R 2	3,92 kΩ ± 1 %	802 371	RÖD				
R 3	10 kΩ	in 300 663	SCHL	R 30	4,75 kΩ ± 1 %	802 045	RÖD
R 4	10 kΩ ± 1 %	802 376	RÖD	R 31	5,62 kΩ ± 1 %	802 046	RÖD
R 5	100 Ω ± 1 %	802 025	RÖD	R 32	5,62 kΩ ± 1 %	802 046	RÖD
R 6	5,62 kΩ ± 1 %	802 373	RÖD	R 33	1,82 kΩ ± 1 %	802 040	RÖD
R 7	2 kΩ ± 10 %	807 673	VIT	R 34	60,1 Ω ± 1 %	802 023	RÖD
				R 35	1,21 kΩ ± 1 %	802 038	RÖD
				R 36	10 kΩ ± 1 %	802 049	RÖD
R 10	274 kΩ ± 1 %	802 066	RÖD	R 37	10 Ω ± 1 %	802 013	RÖD
R 11	4,75 kΩ ± 1 %	802 045	RÖD				
R 12	1,21 kΩ ± 1 %	802 038	RÖD				
R 13	2,2 Ω ± 2 %	802 005	RÖD	R 40	2,21 kΩ ± 1 %	802 041	RÖD

07				Schlumberger Meßgeräte GmbH Ingolstädter Straße 67a 8000 München 46			Schaltteilliste EL. PARTS LIST Bestückte Leiterplatte Typ: 10 MHz REFERENCE		Liste besteht LIST CONSISTS aus OF 3 Blatt SHEETS		
06			Benennung DESCRIPTION								
05							1986		Bezeichnung Schlumberger PART. NO.		Blatt Nr. SHEET NO.  2
04							Tag DATE		361 419 Sa		
03	7088.110	5.4.87	Lei	Name NAME		Herzschaltung SEE CIRCUIT DIAGRAM					
02	7088.97	6.7.87	Le	bearb. BY		214 031 S					
01	7088.83	3.7.87	No.	geodr. DATE		Gerät: 4031					
	6088.21	17.3.86	Skp	Name NAME							
				Name NAME							
				Name NAME							

Diese Zeichnung ist unser Eigentum. Vervielfältigung, unbefugte Verwertung, Mitteilung an andere ist strafbar und schadenersatzpflichtig.



**1. 500-MHz oscillator 361 448**

This can be tuned by  $\pm 20$  MHz. T6 through T9 serve for filtering the operating voltage for T1, which generates the oscillations. The RF signal is fed via buffer amplifiers to Mi1 of the mixer chain and to the output of the decade synthesizer.

**2. 200-kHz decade 361 445**

Oscillator T3 generates frequencies between 77.4 and 97.2 MHz. The phase-locked loop consists of D1, D2 and A1. D1 is a 10/11 divider. D2 forms the programmable phase comparator, and A1 is the loop filter.

**3. Mixer 361 447**

The first mixer on the mixer circuit board receives a test frequency of 433.82 MHz from the output stage. The second frequency is supplied by the 500-MHz oscillator with possible detuning of  $\pm 20$  MHz. The intermediate frequency is applied on the one hand to a 100-MHz amplifier that is switched in analyzer mode and conducts the IF to the AF motherboard. On the other hand this frequency serves as the RF for Mi2. The 200-kHz decade generates the LO signal. The 11.12 to 11.32 MHz formed in this way is applied to phase detector 361 449. In synthesizer mode the phase detector compares 11.12 to 11.32 MHz from the mixer circuit with the same frequency from the FM stage. Mi1 is configured as a zero-phase detector. Mi2 forms the image-frequency detector. If the oscillator is not synchronized, a delta signal is produced. If the frequency that is to be compared is approx. 11 MHz, the time constant of the delta generator is increased. The generator halts when there is phase coincidence. In analyzer mode the 500-MHz oscillator receives a sawtooth-shaped varactor voltage from integrator A2. The reference voltage required for the integrator is generated by A1-A. The integrator on is fed by two series-connected 8-bit D/A converters.

Ref.No. 210 041 F	Sub Decade Synthesizer	Date
Type 4031	Unit	Sheet 1/2
Schlumberger		Functional Description

The integrator has a 10-V reference, so the voltage issued by the second D/A converter is subtracted from 10 V =  $V_a$ . For the return trace of the analyzer,  $V_a$  is multiplied by 0.5 (A1 - B) and added to 10 V.

$$\underbrace{8 \text{ bits} + \text{Clock}}_{Z_1} = V_1$$

$$V_1 = \frac{Z_1 \times 10 \text{ V}}{256}$$

$$V_2 = - \left[ \frac{Z_2 \times V_1}{256} \text{ V} \right] + 10 \text{ V} \quad Z_2 \text{ is entered without timing}$$

$$V_3 = (V_2 \times 0.5) + 10 \text{ V}$$

#### 4. 10-MHz divider 361 446

The circuit board 361 446 has two functions. Firstly, 10 MHz is divided by two and fed to the 200-kHz decade. Secondly, the 433.82-MHz sawtooth signal produced by the output stage is fed via a buffer amplifier to the mixer chain.

Ref.No. 210 041 F  
Type 4031

Sub Decade Synthesizer  
Unit

Date  
Sheet 2/2

Necessary Equipment	Measuring Procedure	Measuring Point	Frequency	Adjustment	Set Value	Actual Value	Sub Unit				Sheet	
							Issue	Alteration No.	Date	Name		Ref. No.
Basic unit 4031, Oscilloscope  DVM	<p><u>Decade stage 210 041</u></p> <p>Coarse decade 200 kHz, 361 445 Chassis fitted with all PCBs</p> <p>Measure reference frequency Switch on oscillator = analyzer off Set frequency to 77.4 MHz (= 500 MHz on 4031) and measure control voltage Set frequency to 97.4 MHz (= 519.9 MHz on 4031) Measure 100 kHz spurious with oscilloscope Switch off oscillator = analyzer on</p>	Bu4 Bu10 Bu11 A1/pin 6 Bu11 A1/pin 6 A1/pin 6  Bu10 Bu11	5 MHz DC 77.4 MHz DC 97.4 MHz DC AC  DC	R16	5 MHz TTL Low $V_a > 0.7 V_{pp}$ $V_c \approx -11.5 V$ $V_a > 0.7 V_{pp}$ $V_c = 0-3 V$ Minimum typ. 100 mVpp High $V_a = 0 V_{pp}$		Ref. No. 210 041 A  Type STABILOCK 4031					1/4

Necessary Equipment	Measuring Procedure	Measuring Point	Frequency	Adjustment	Set Value	Actual Value																								
							Issue	Name	Date	Alteration No.	Issue	Name	Date	Alteration No.	Ref. No.	Type	Sub Unit	Sheet												
PSU 0-15 V, Analyzer, Counter,  DVM	<u>Oscillator 480-520 MHz, 361 448</u>  Separate detector on 361 403 Apply +5 V to Bu1 from PSU  With 1:10 probe on Bu41 Measure on lead-through with 1:10 probe Go to 540 MHz with control voltage Frequency response Oscillator reserve: $V_C = 0-15 V$	Bu40  Bu41 Lead-thru Bu40 Bu41 Bu40	475 MHz  475 MHz 475 MHz 540 MHz 480-540 MHz < 475 MHz > 545 MHz	CI  Analyzer	475 ±1 MHz  $P = 7 \text{ dBm}$ same level $V_C = 11.2-11.7 V$ $P_{\Delta} = 3-7 \text{ dBm}$ $V_C = <5 V$ $V_C = >12 V$																									
Basic unit 4031 PSU 0-15 V RF generator  Analyzer	<u>Mixer chain 361 447</u>  Analyzer off Set 500 MHz on basic unit Set oscillator 361 448 manually to approx. 500 MHz SAW 433.82 MHz -15 dBm (from output stage to Bu55) Analyzer on, 500 MHz Tune oscillator 361 448 manually from 480 through 540 MHz	Bu1  Bu40	≈ 11.22 MHz  48.18-106.18 MHz		$V \approx 1.5 V_{pp}$  $P = +3 \text{ to } -7 \text{ dBm}$																									
<table border="1"> <thead> <tr> <th>Issue</th> <th>Alteration No.</th> <th>Date</th> <th>Name</th> <th>Issue</th> <th>Name</th> <th>Date</th> <th>Alteration No.</th> <th>Ref. No.</th> <th>Type</th> <th>Sub Unit</th> <th>Sheet</th> </tr> </thead> <tbody> <tr> <td></td> <td></td> <td></td> <td></td> <td></td> <td></td> <td></td> <td></td> <td>210 041 A</td> <td>STABLOCK 4031</td> <td>Decade Synthesizer</td> <td>2/4</td> </tr> </tbody> </table>							Issue	Alteration No.	Date	Name	Issue	Name	Date	Alteration No.	Ref. No.	Type	Sub Unit	Sheet									210 041 A	STABLOCK 4031	Decade Synthesizer	2/4
Issue	Alteration No.	Date	Name	Issue	Name	Date	Alteration No.	Ref. No.	Type	Sub Unit	Sheet																			
								210 041 A	STABLOCK 4031	Decade Synthesizer	2/4																			

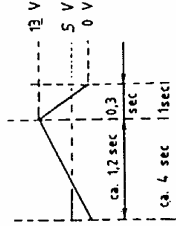

Necessary Equipment	Measuring Procedure	Measuring Point	Frequency	Adjustment	Set Value	Actual Value	Ref. No. 210 041 A				Sub Unit	Decade Synthesizer	Sheet
							Issue	Alteration No.	Date	Name			
Oscilloscope	<p>Analyzer off</p> <p><u>Phase detector 361 449</u></p> <p>Disconnect SAW 433.82 MHz, join detector</p> <p>Phase detector is unsynchronized</p> <p>Set sweep generator</p>	Detector		R54									
	<p>SAW 433.82 MHz on Bu55, set frequency on basic unit</p>	A4/pin 9	DC	L6	<p>Maximum typ. &gt; 2 Vdc</p>								
	<p>Vary frequency from 500-520 MHz</p> <p>Adjust spurious in synthesizer mode</p> <p>Carrier ±11.2 MHz</p> <p>Carrier ±22.4 MHz</p>	Bu41	500-520 MHz	L3 L2	<p>f = synchronized</p> <p>&gt; 70 dBc</p> <p>&gt; 70 dBc</p>								
Counter, Analyzer	<p>Analyzer on</p> <p>Set 10 V on PSU</p> <p>Apply data to connector 54</p>	A1/pin 1	DC	R15	+10.0 V								
	<p>PR adapter</p> <p>5b 6a 6b 7b 8b 9b 10b 7a 8a 9a 10a</p> <p>1 0 1 0 1 0 1 0 1 0 1</p> <p>1 0 1 0 1 0 1 0 1 0</p> <p>————— Data lines</p> <p>(per Hand) Clock</p> <p>(per Hand) P/DP</p>	Bu13 Bu13 (detector)	DC DC			<p>5 V ± 475 MHz</p>							
Issue	Alteration No.	Date	Name	Sub Unit		Decade Synthesizer		Sheet					
				Type		STABILLOCK 4031		3/4					



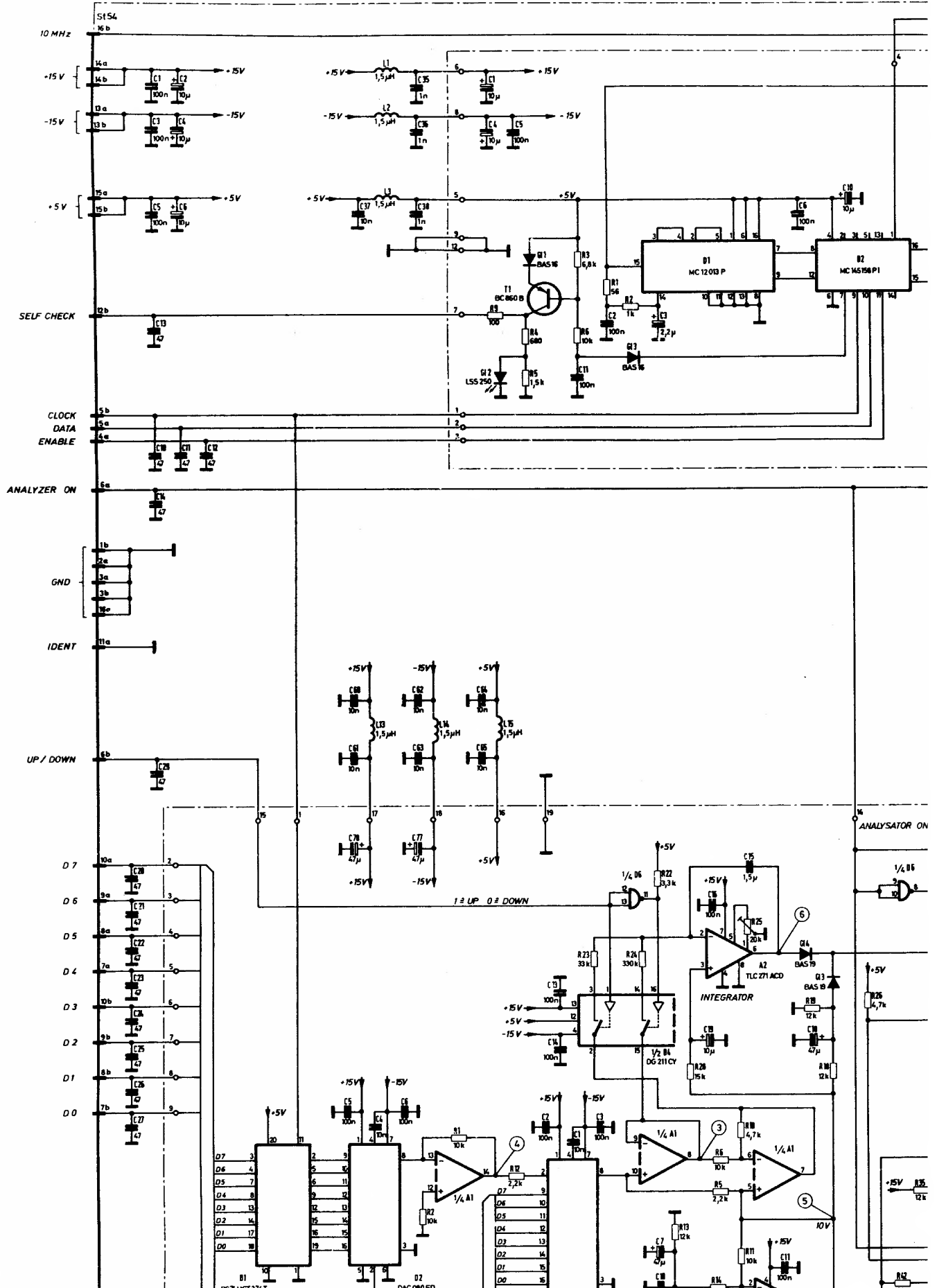

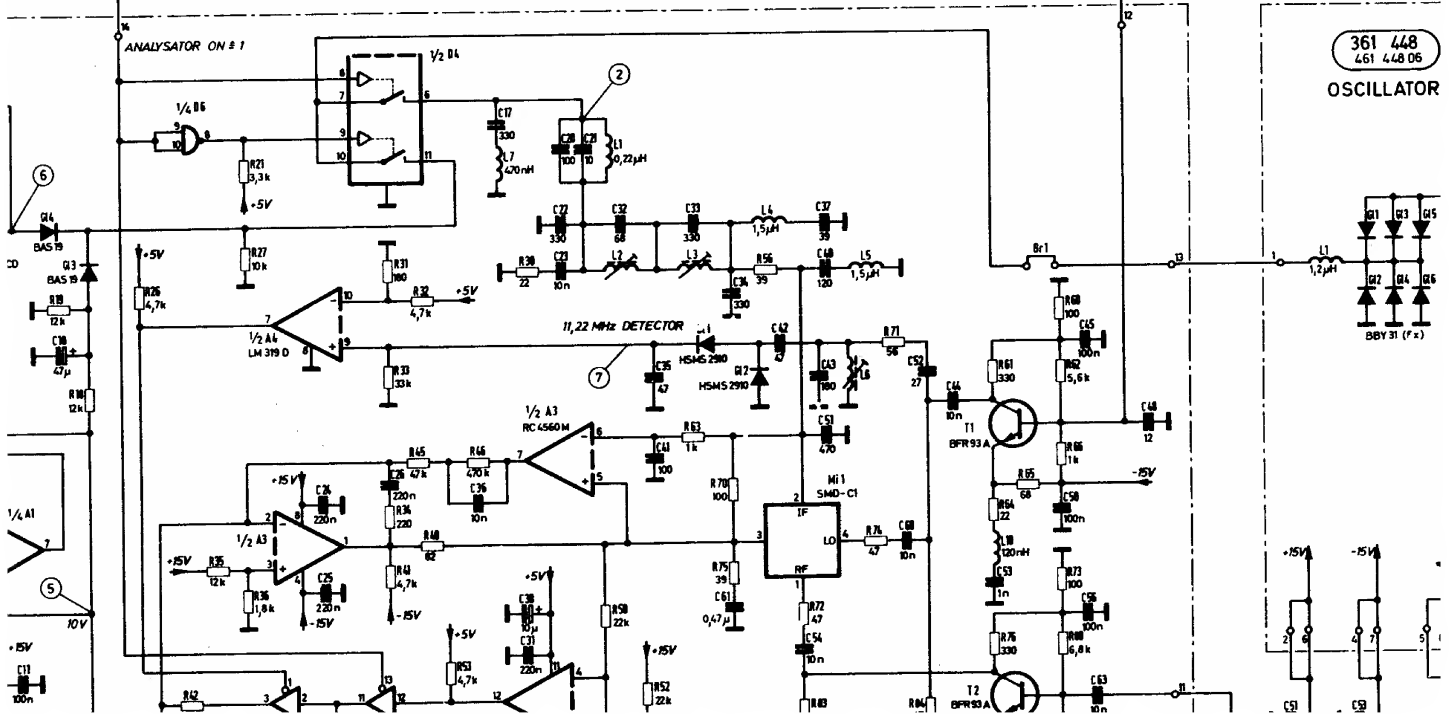
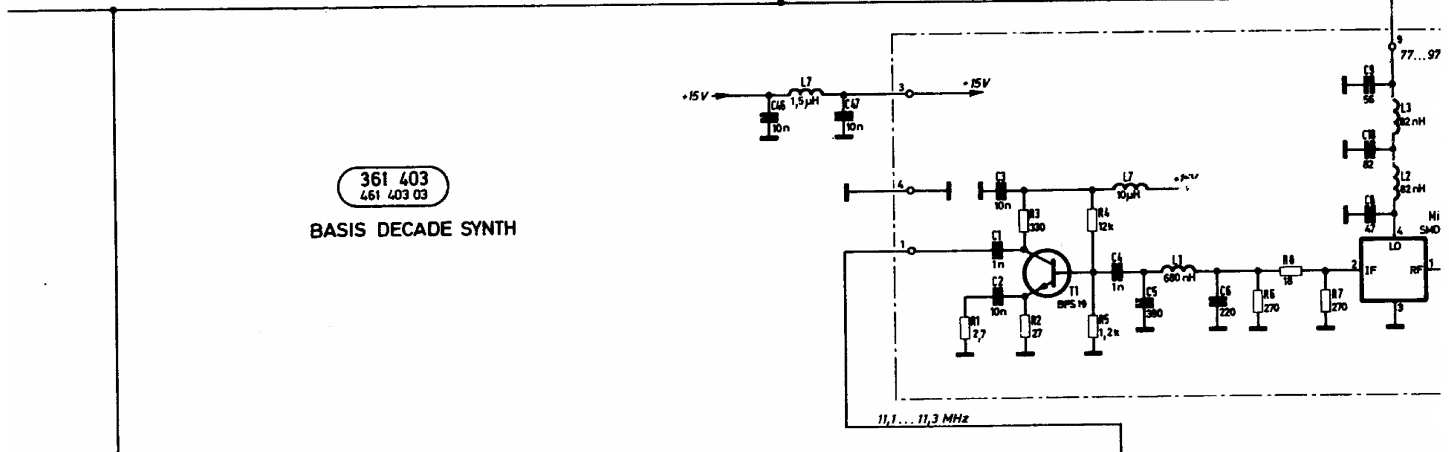
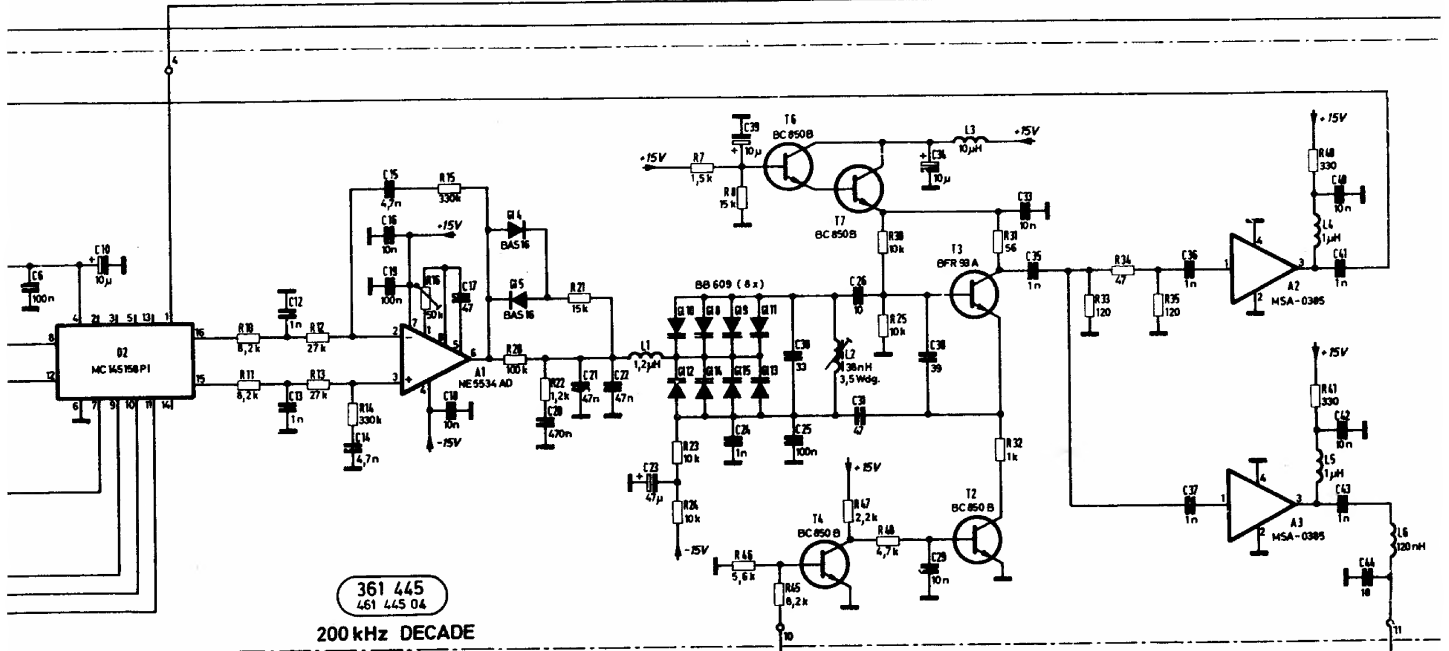

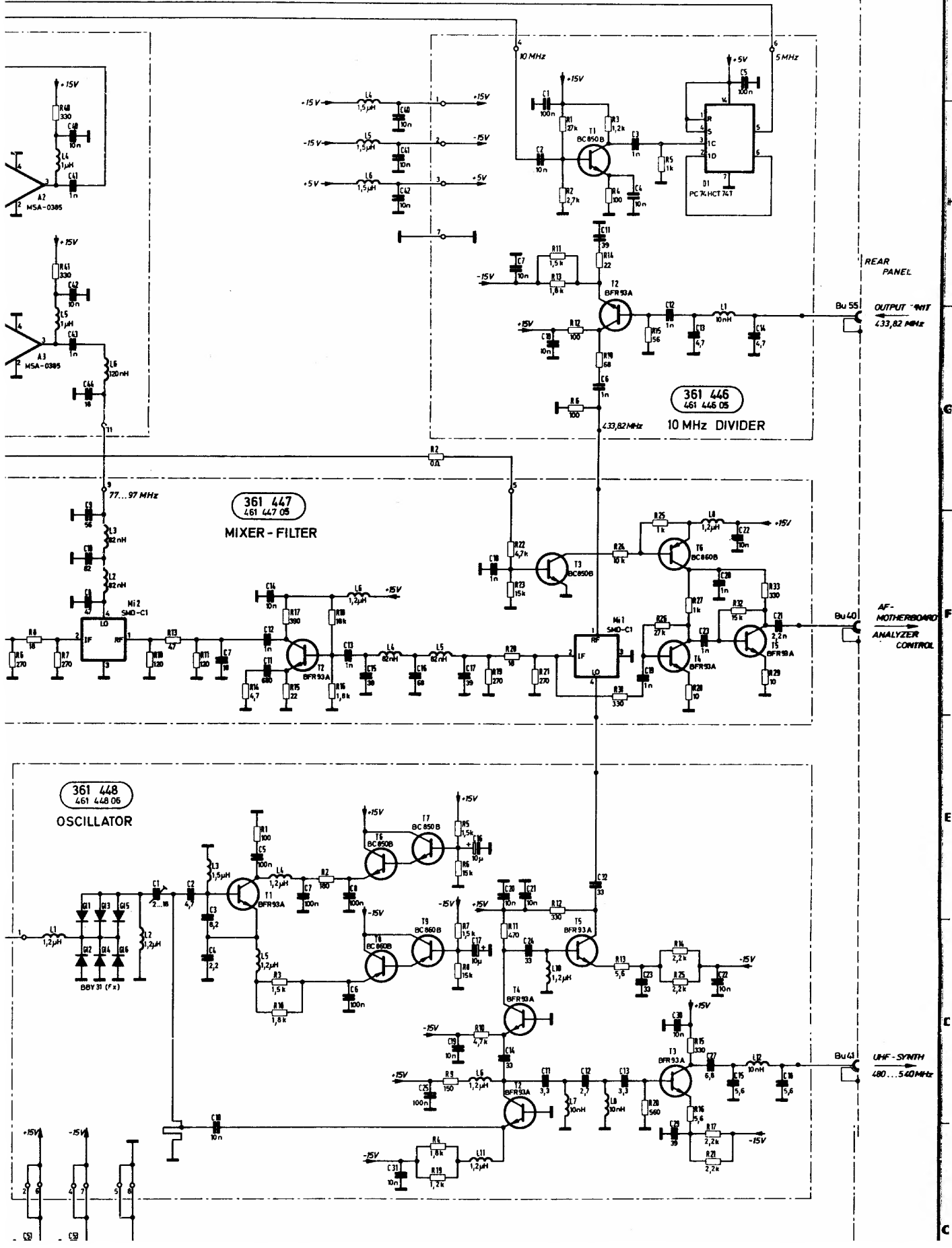

REAR PANEL  
OUTPUT UNIT  
433,82 MHz

Bu40  
AF-MOTHERBOARD  
ANALYZER CONTROL

Bu41  
180...540 MHz

361 447  
461 447 05  
MIXER - FILTER

361 446  
461 446 05  
10 MHz DIVIDER

361 448  
461 448 06  
OSCILLATOR

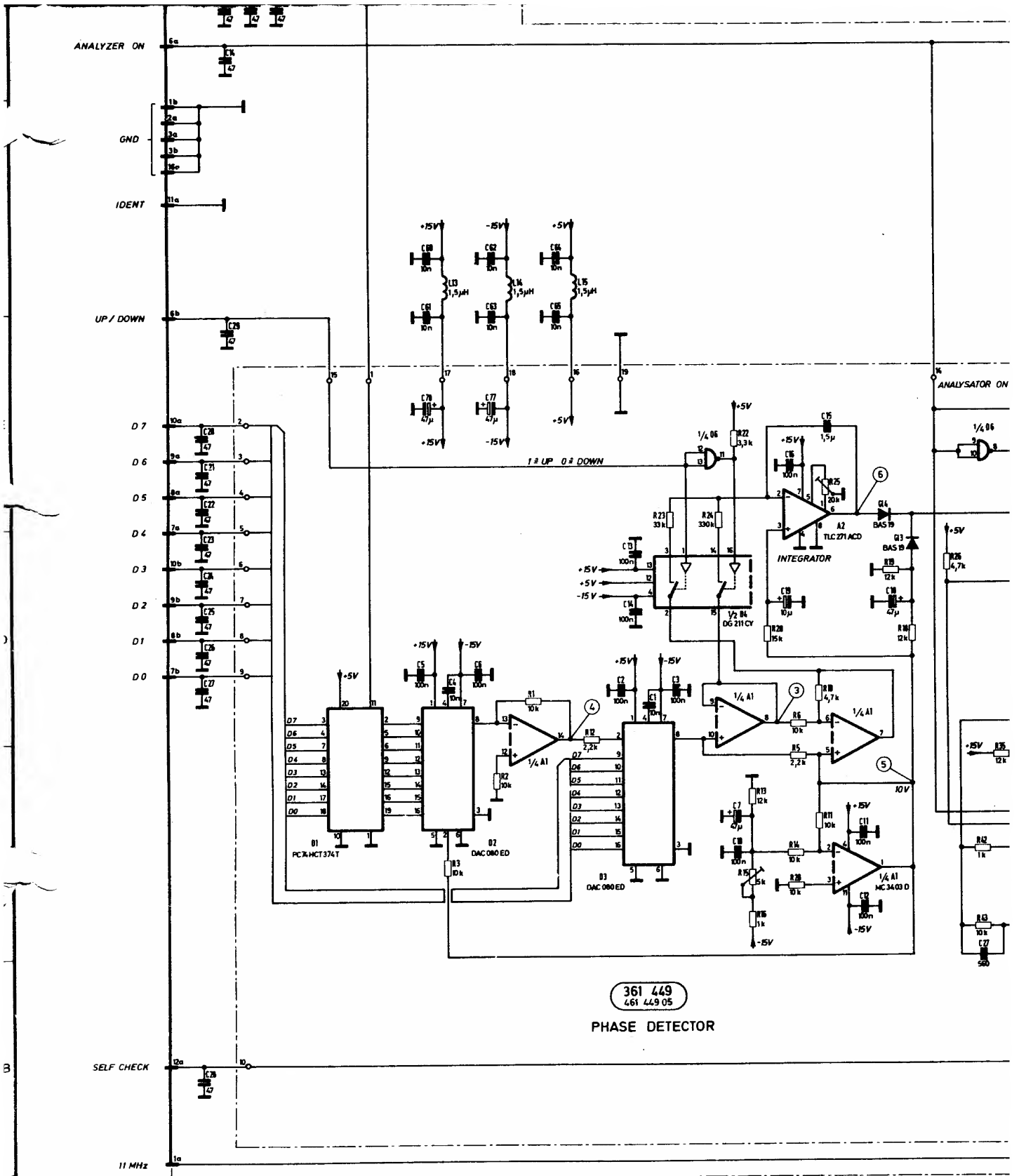

361 403  
461 403 03

BASIS DECADE SYNTH

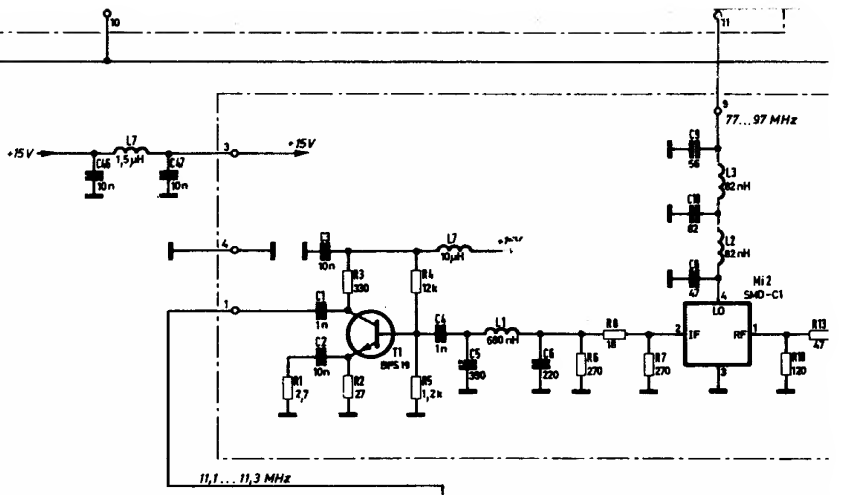

361 448  
461 448 06

OSCILLATOR

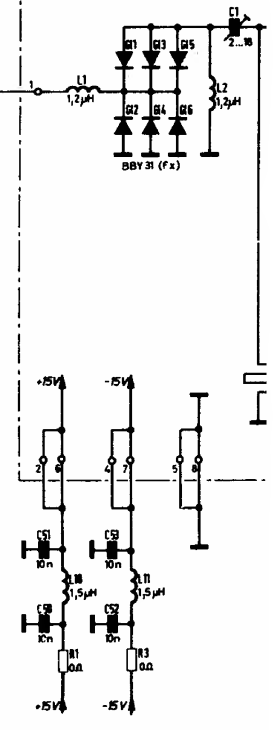

ANALYSATOR ON # 1

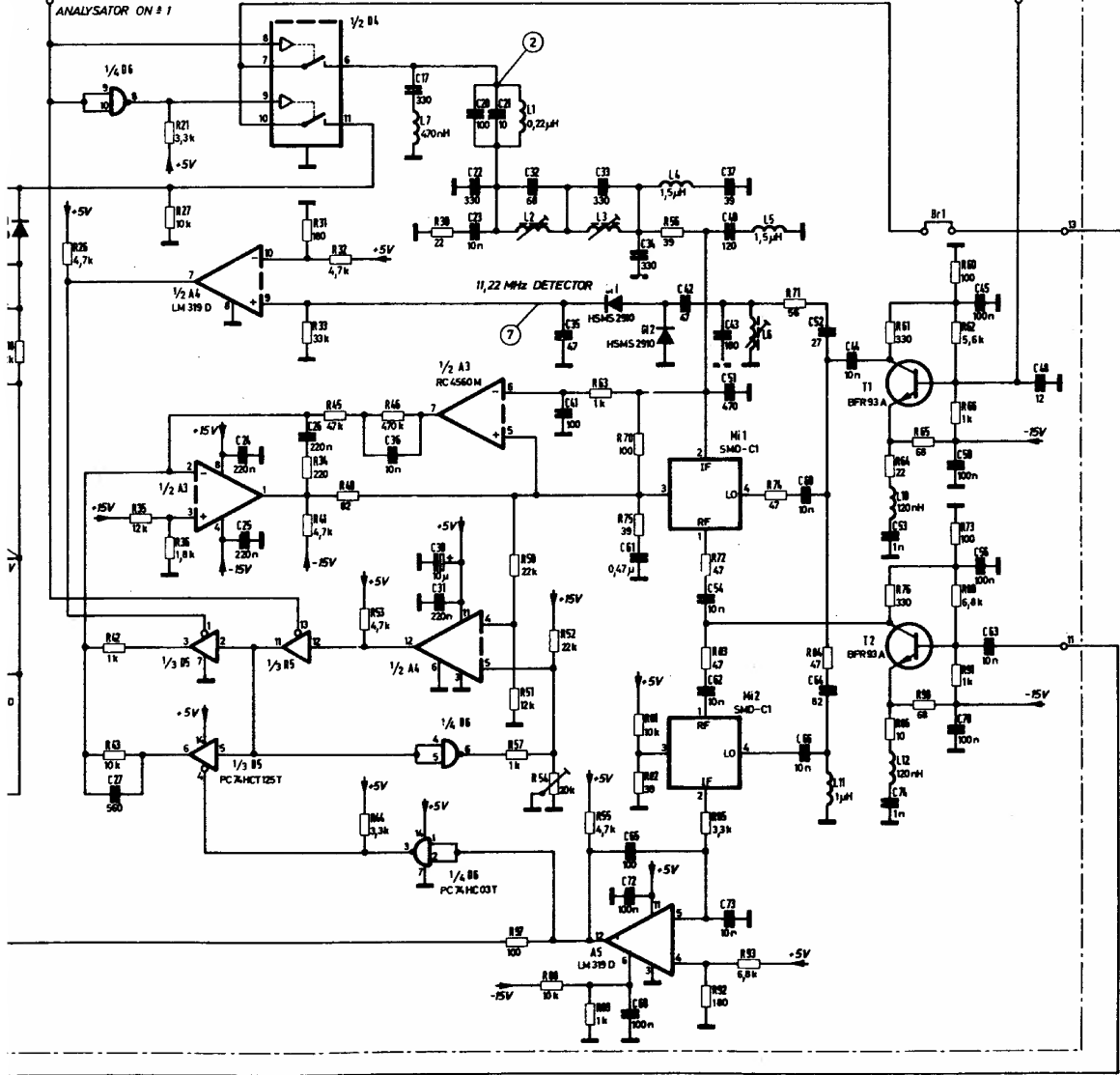

sw	BLACK	M	BLUE
br	BROWN	v	VIOLET
rd	RED	gr	GREY
ro	ROSE	wh	WHITE
yl	YELLOW	tr	TRANSPARENT
grn	GREEN		

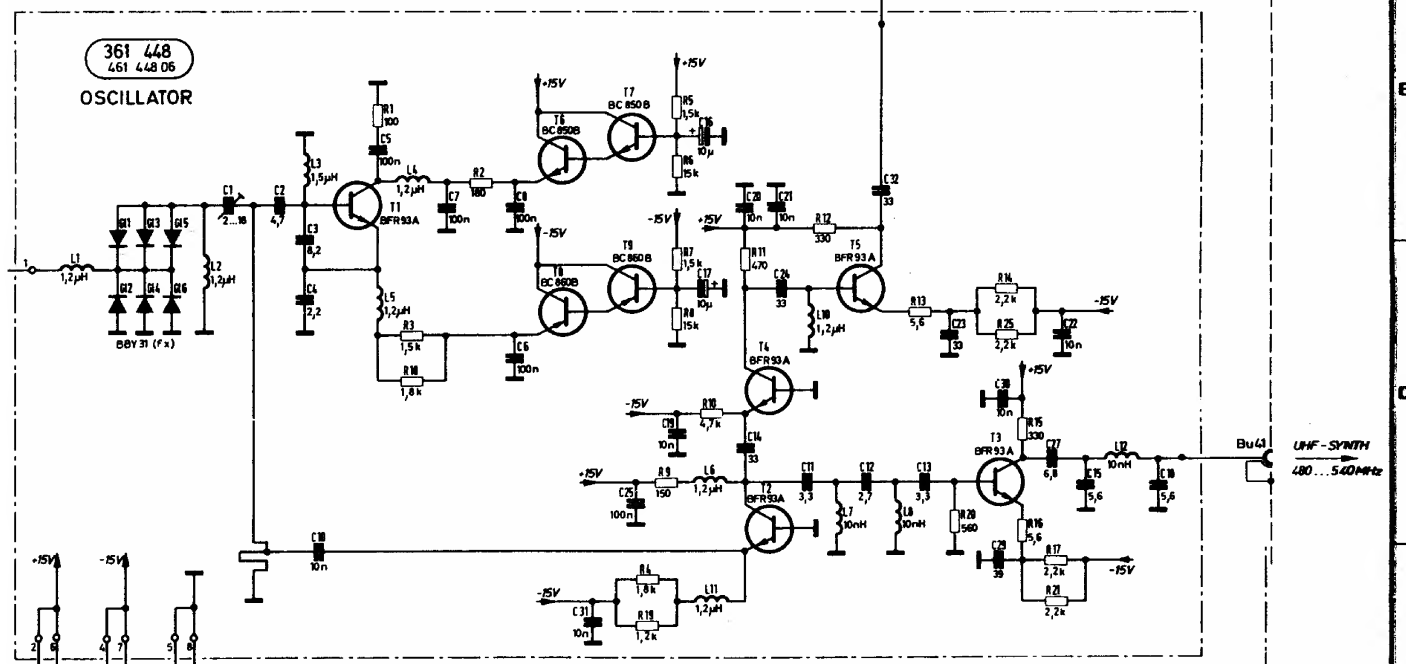
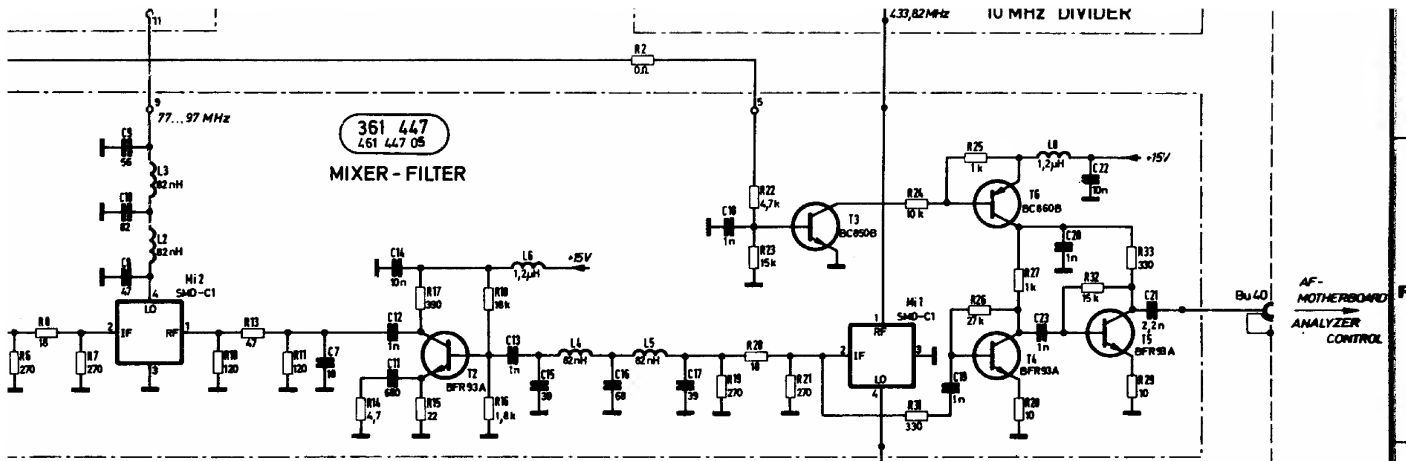

Zeichnungsausgabe

ISSUE	△ Serie
03	L 388
04	L 488
05	L 588
06	L 588
07	L 488 / L 588
08	L 588

■ BLACK  
 ■ BROWN  
 ■ RED  
 ■ ROSE  
 ■ YELLOW  
 ■ GREEN  
 ■ BLUE  
 ■ VIOLET  
 ■ GREY  
 ■ WHITE  
 ■ TRANSPARENT

US 8088 204 25 28 04 07	norm	44
Ausg A. Metzger Datum 1988	beerb 1.8.88	Kc
ISS MODIF DATE NAME	1988	DATE NAME

Schlumberger Meßgeräte GmbH  
 Ingotstädter Straße 67 a  
 8000 München 48

**DECADE SYNTH**

**210 041 S**  
 Gerät: 4031



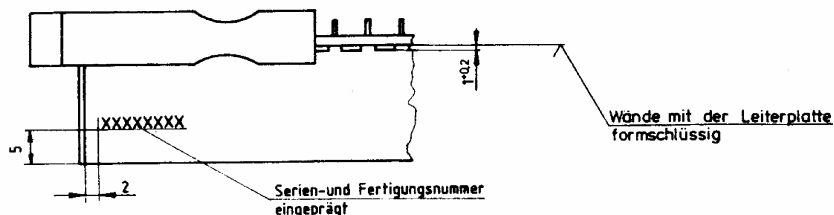
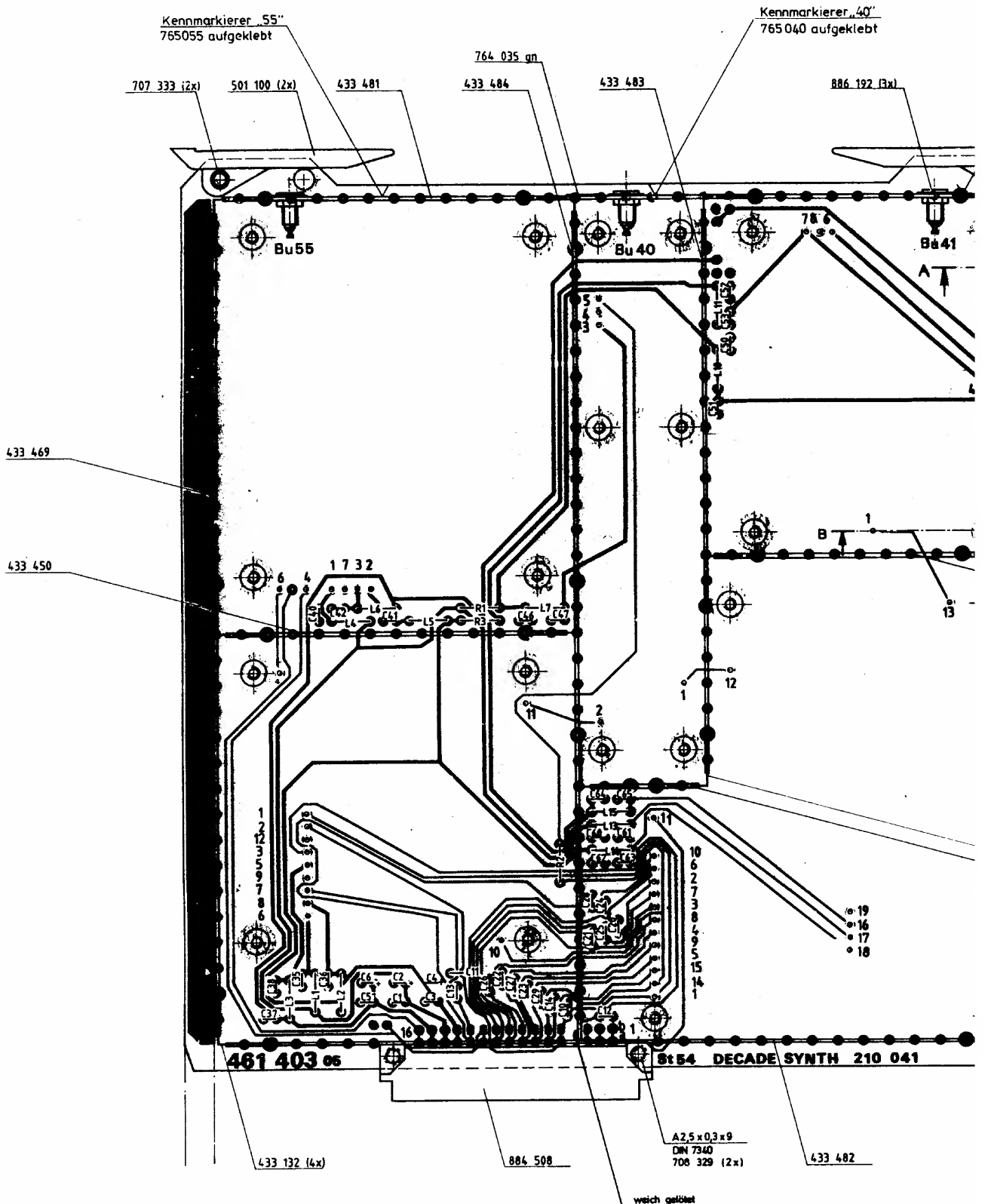

weich gelötet

nnmarkierer „40“  
5040 aufgeklebt

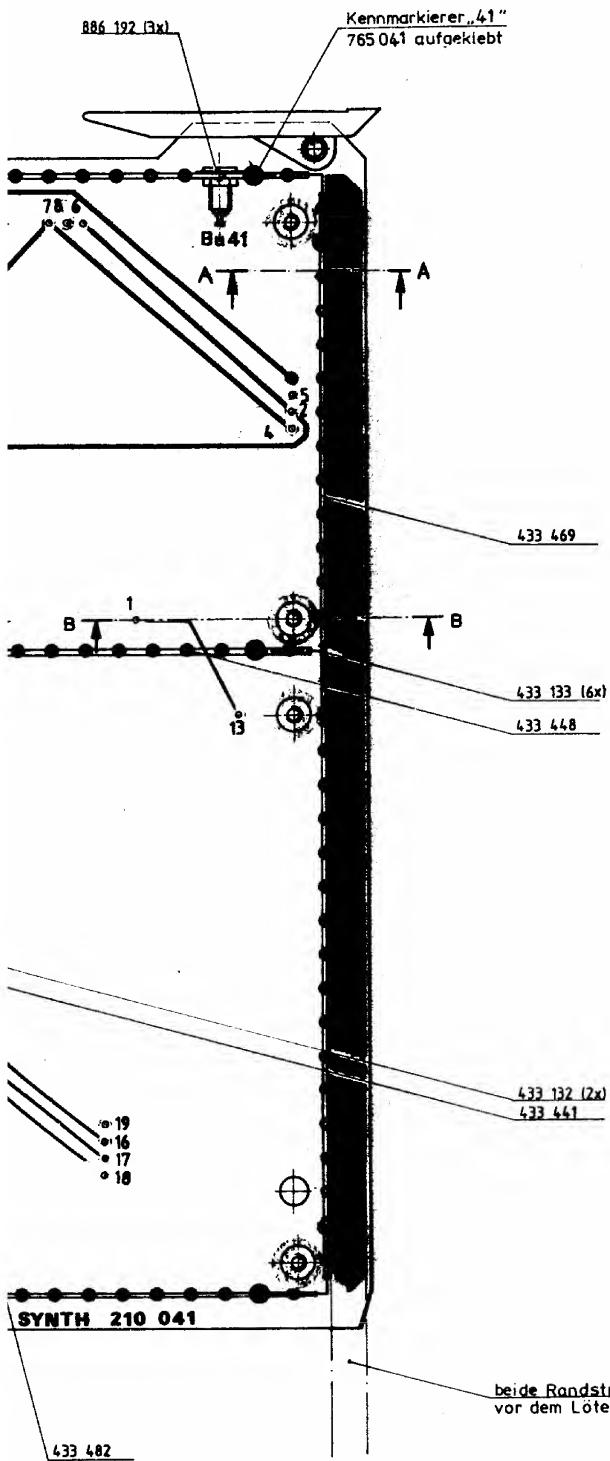

Schnitt A-A

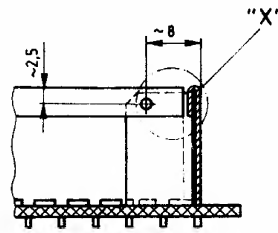

Einzelheit "X"  
M 5:1

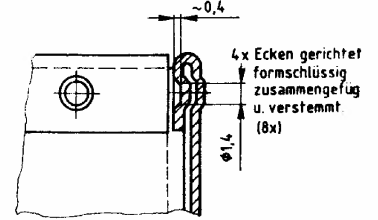

Schnitt B-B

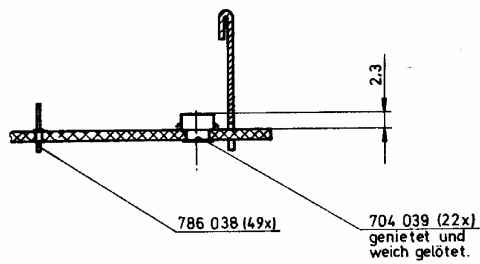

○ = Kontrollmaß

10 886 192 23.8.88. 10. 09 886 192 25.5.88. 10. 08 704 039 21.3.88. 10. 07 786 038 21.3.88. 10. 06 786 038 13.6.87. 10. 05 704 039 13.6.87. 10. 04 433 132 11.8.84. 10. 03 433 132 11.8.84. 10. 02 433 132 11.8.84. 10. 01 433 132 11.8.84. 10.	Schlu Ingolstädter Straße 67 a 8000 München 46
2:1 (5:1)	Bestückte Leiterplatte Typ. Basis DECADE SYNTH
361 403	Gerät: 433 / 228 441

ndet in:

Gerät:

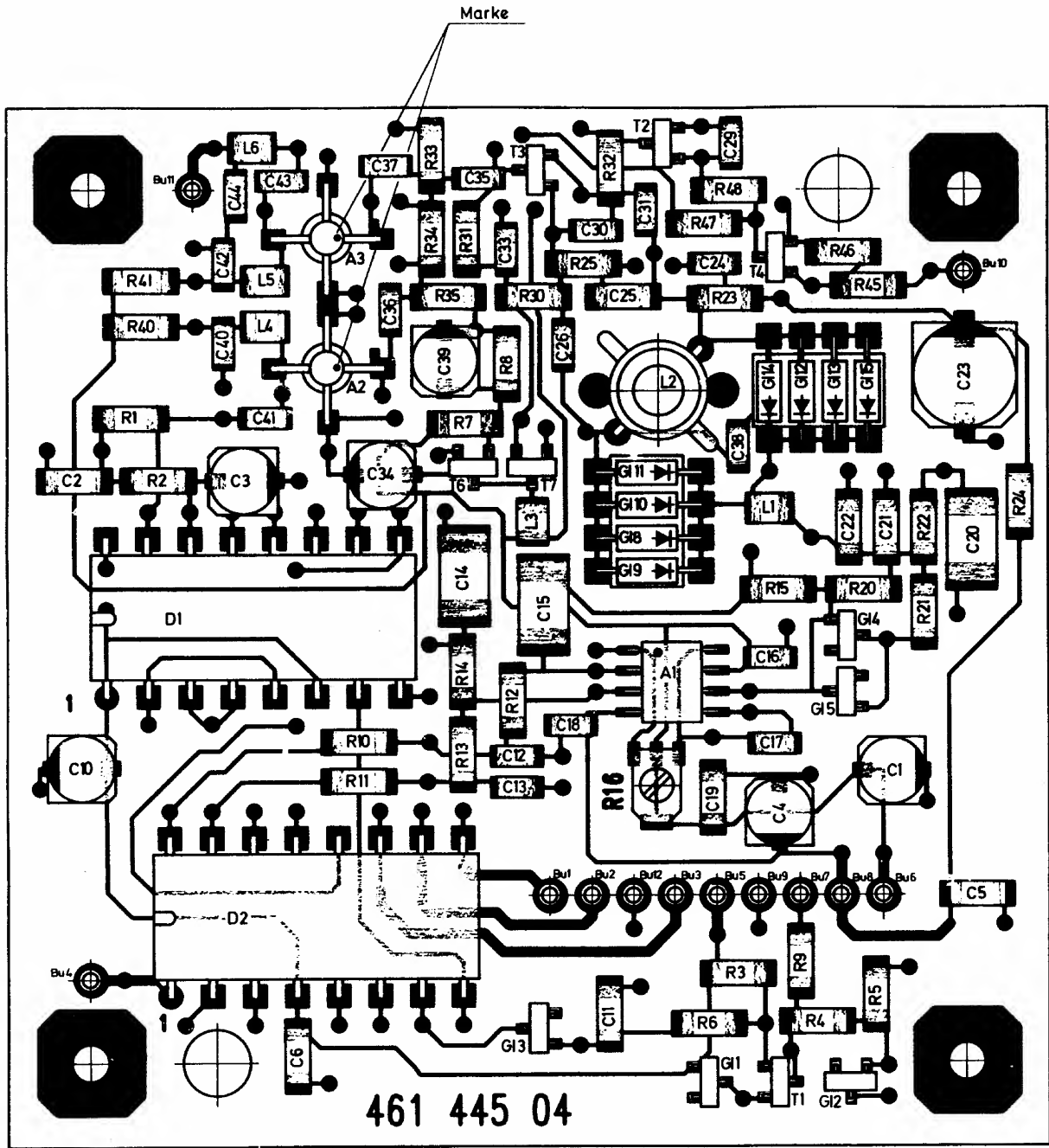



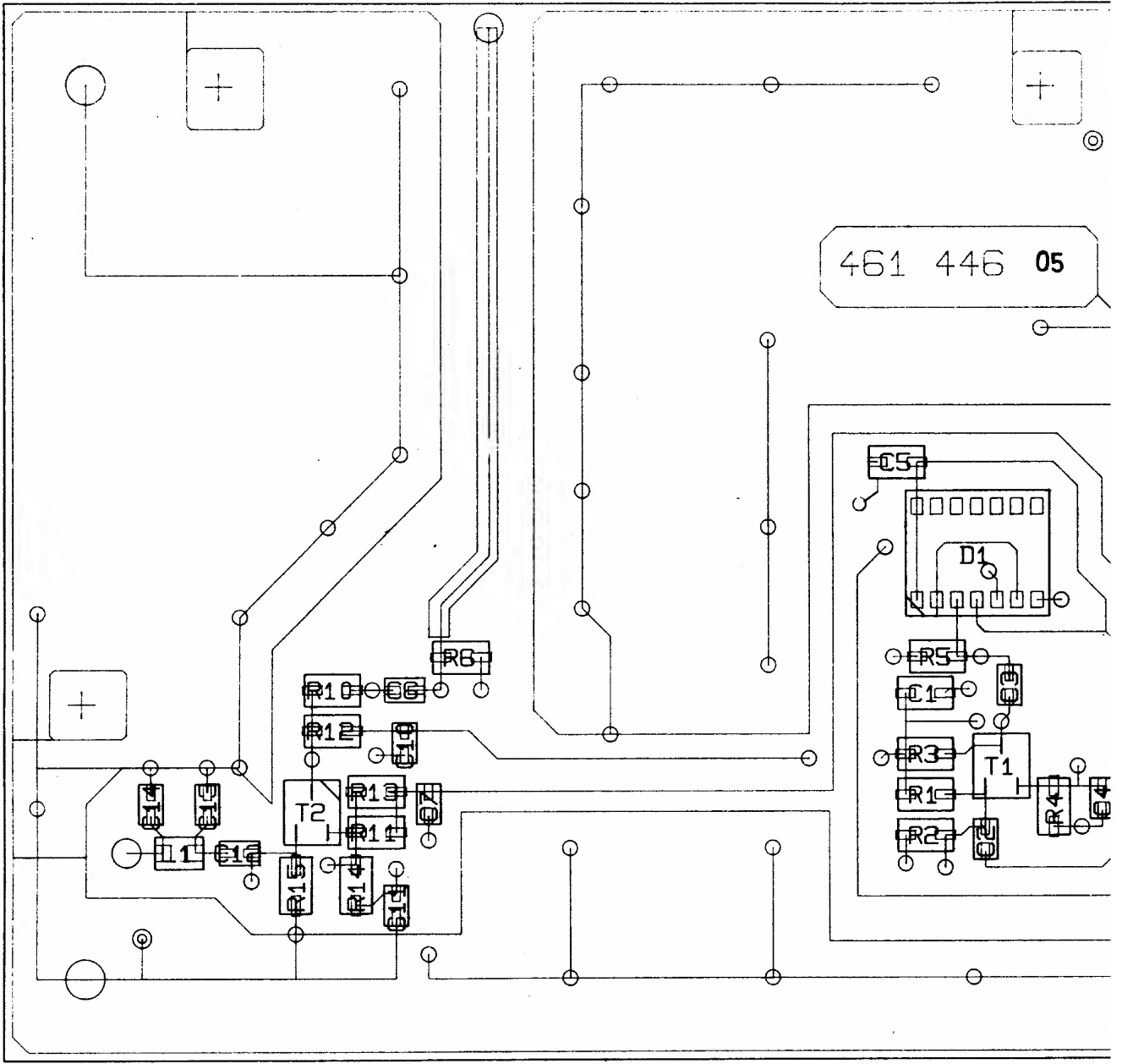

Reflow gelötet  
 hierzu Bauteilklebmaske 461 446 05

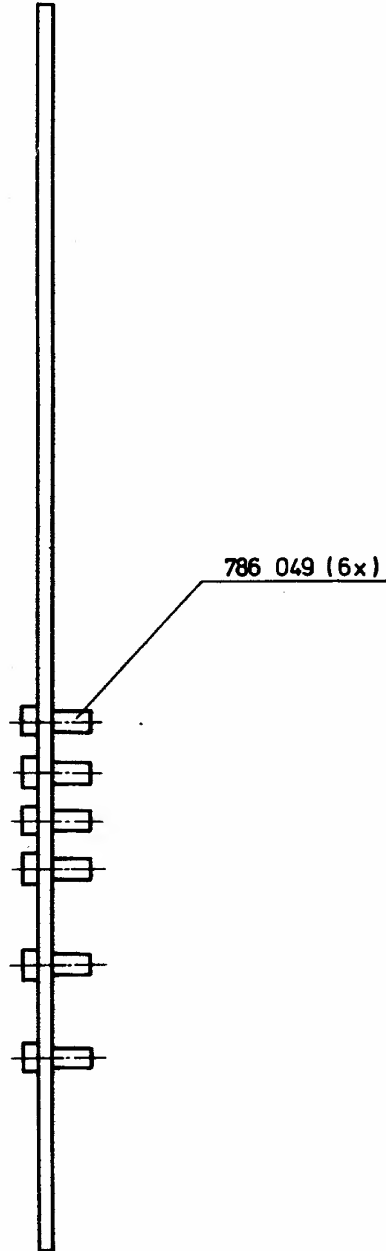
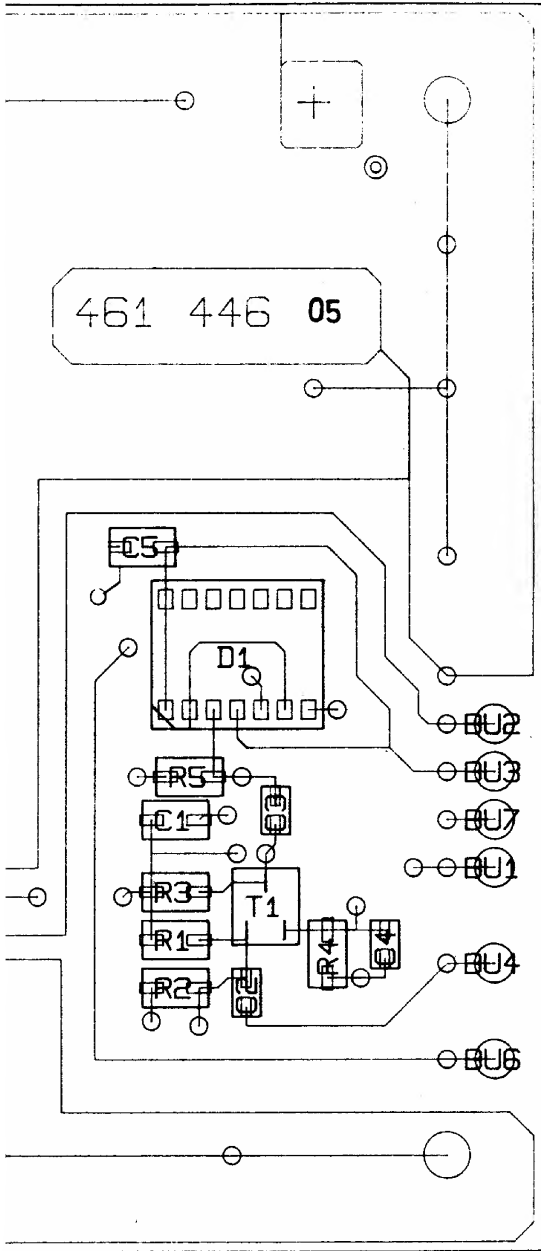

○ = Kontrollmaß

10				Periode:	Fremd- toleranzen:	Maßstab:	Schlumberger Meßgeräte GmbH Ingoisbacher Straße 87 a 8000 München 48
09					±0,2	4:1	
08				Werkstoff:			Bestückte Leiterplatte Typ: 10 MHz DIVIDER
07	22.11.87						
06	20.11.87						
05	20.11.87			Oberfläche:	Stk/Datum sm. 20.11.87	Name Str.	361 446
04							
03				Ausgabe:	Ange- messe	Datum	Name
02							
01							
				Größ: 461 / 78 049			

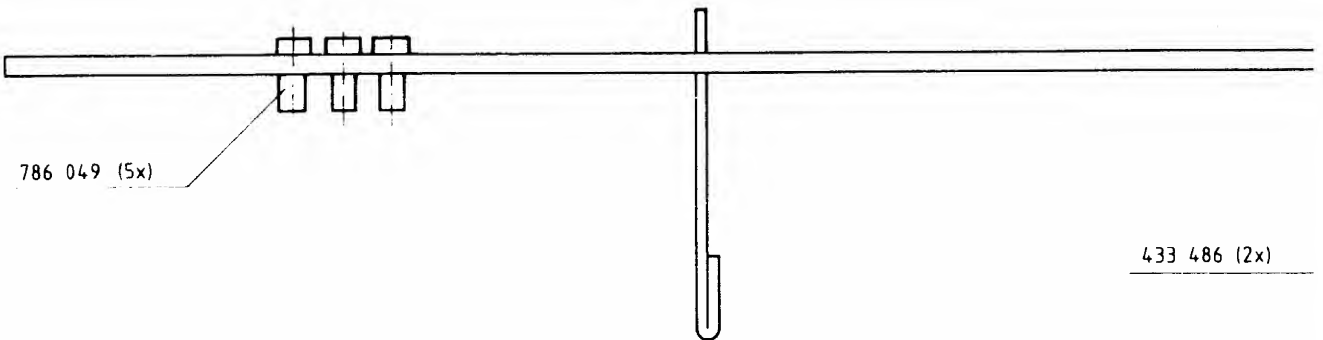
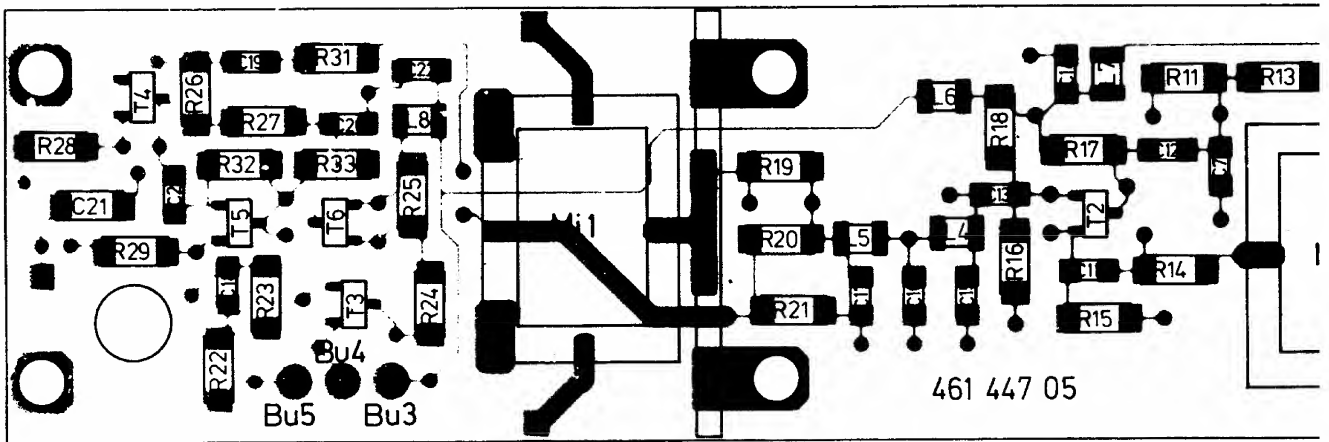

<p>nummerung <math>\cong</math> 210 041 S/361 447 Sa</p>	<p>verwendet in:</p>	<p>Gerät:</p>
--	----------------------	---------------

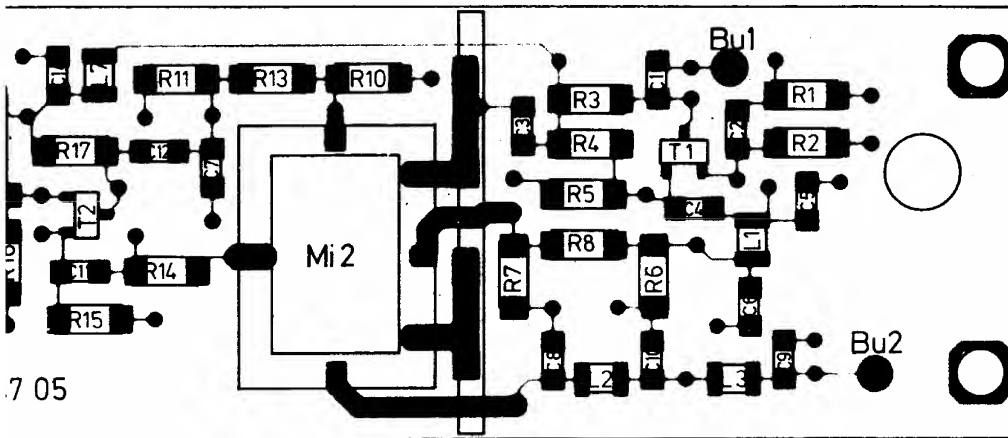

7 05

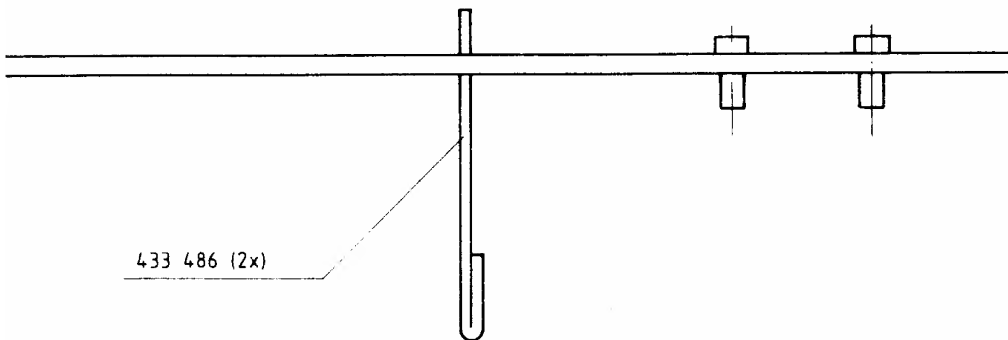

433 486 (2x)

10				Rohrloch		Maßstab	Schlumberger Meßgeräte GmbH Ingoistacher Straße 67 a 8000 München 48
09						4:1	
08							
07							
06	02.03.78	25.1.88	25.1.88	Werkstoff			361 447
05	02.03.78	25.1.88	25.1.88				
04	02.03.78	25.1.88	25.1.88				
03	02.03.78	25.1.88	25.1.88				
02	02.03.78	25.1.88	25.1.88	Oberfläche			
01							
Ans.gabe	Ans.gabe	Datum	Name				

Gerät:



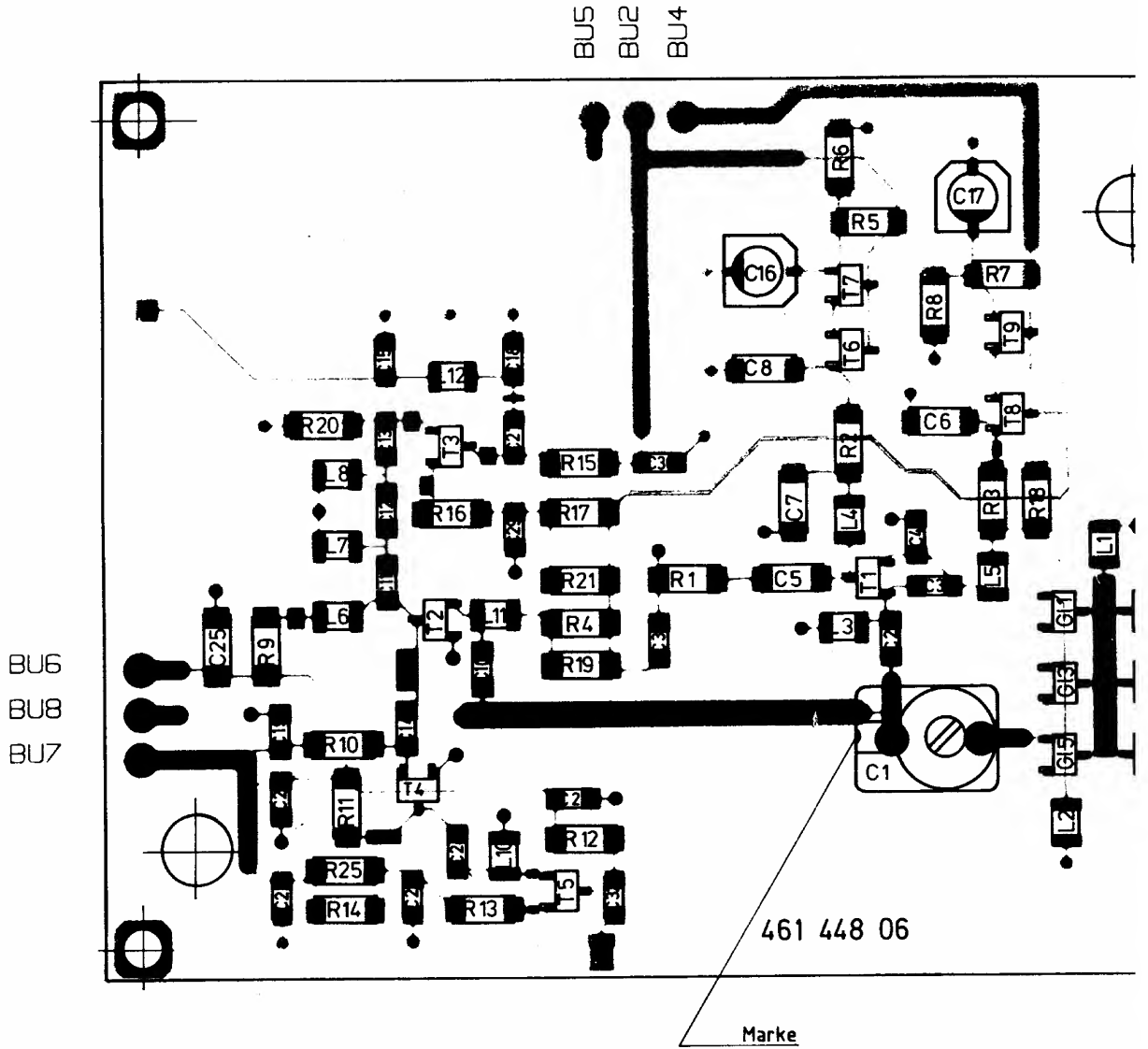

Reflow gelötet  
 hierzu Bouteillennormale  
 461 448 06

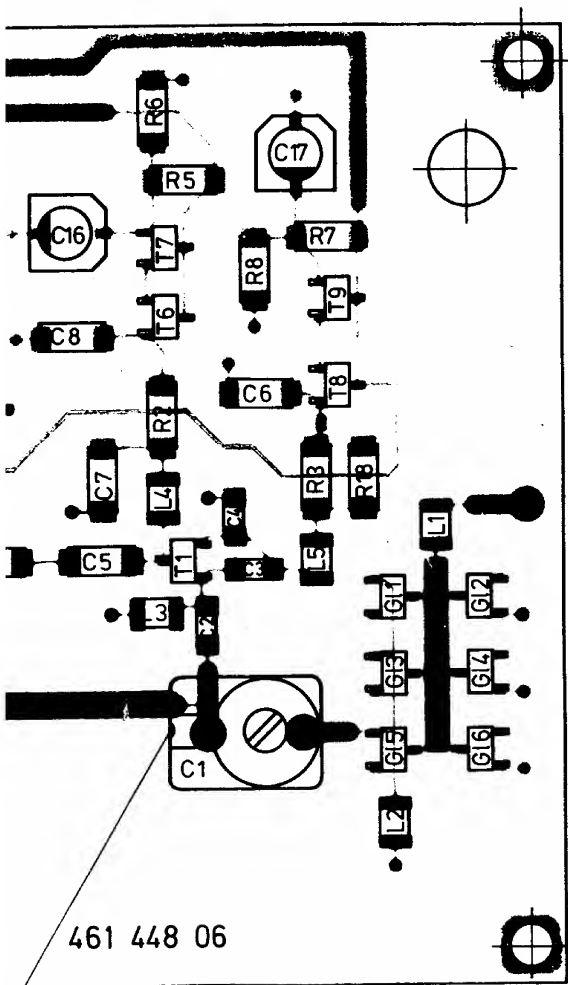

BU1

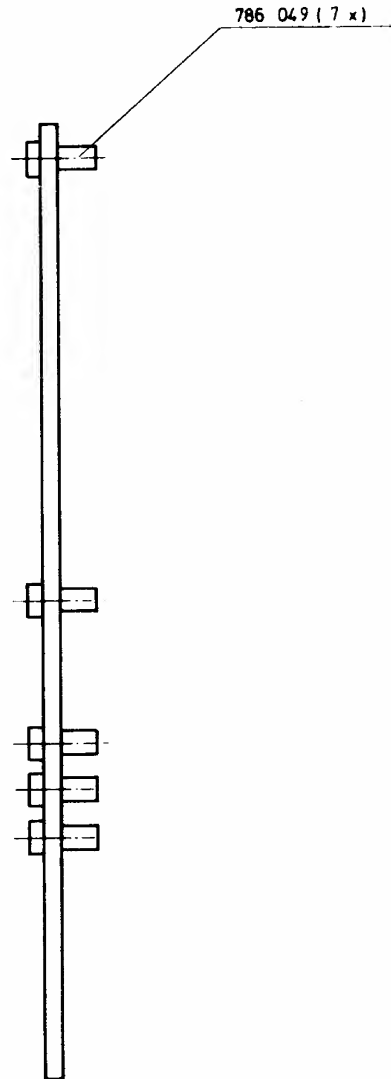

461 448 06

Marke

Gerät: 4031

10				Prüfung					Schlumberger Meßgeräte GmbH Ingolstädter Straße 67 a 8000 München 48
09									
08									Bestückte Leiterplatte Typ: OSCILLATOR
07	1000,00	95,88	Fl.	Work shop	±0,2	4:1			
06	1000,00	25,15	Fl.						
05	1000,00	21,56	ADH						
04	1000,00	28,87	Fl.						
03	1000,00	4,27	Fl.	Oberfläche					
02	1000,00	20,00	Fl.						
01	1000,00								
Aut. gabe		Änd. gabe	Datum	Name	Prüf. Datum	Name	Prüf. Datum	Name	361 448 461 448 06

Diese Zeichnung ist unser Eigentum. Vervielfältigung, Verbreitung, Nachdruck, Abdruck oder andere Art der Vervielfältigung ist ohne schriftliche Genehmigung der Schlumberger Meßgeräte GmbH.

884 179  
884 182

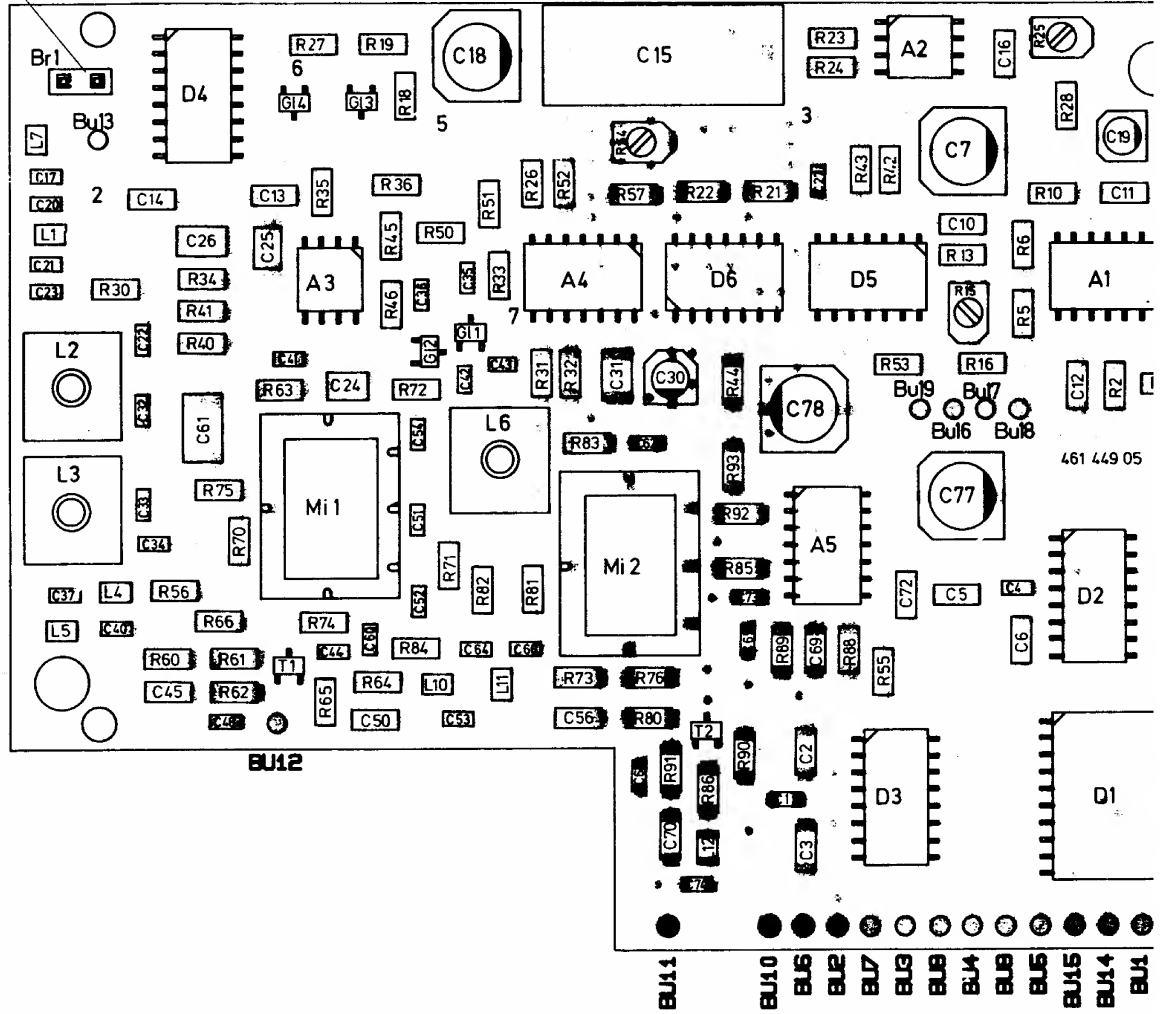

max 2

verwendet in:

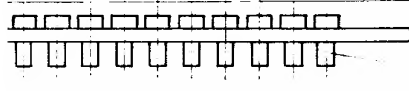
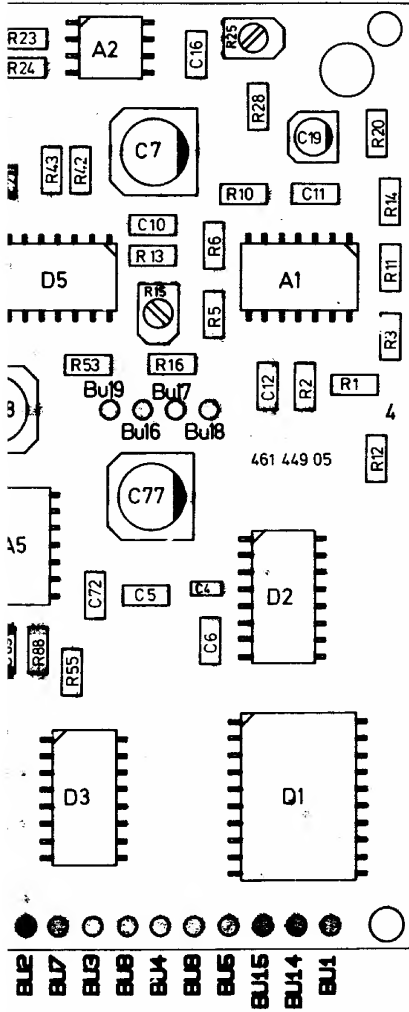

786 049 (19x)

○ Kontrollmaß

let in:	Gerät:		4:1	Schlumberger Meßgeräte GmbH <small>Ingostrader Straße 6/7a                  80333 München 46</small>
				Bestückte Leiterplatte Typ PHASE DEECTOR
				361 449

1	2	3	4	5	6	7	8
Pos. REF. NO.	Wert VALUE	Bezeichnung Schlumberger PART. NO.	Hersteller MANUFACT	Pos. REF. NO.	Wert VALUE	Bezeichnung Schlumberger PART. NO.	Hersteller MANUFACT
1	Bestückte Leiterplatte PRINTED CIRCUIT BOARD	361 403	SCHL				
	hierzu see	361 403 Sa					
1	Bestückte Leiterplatte PRINTED CIRCUIT BOARD	361 445	SCHL				
	hierzu see	361 445 Sa					
1	Bestückte Leiterplatte PRINTED CIRCUIT BOARD	361 446	SCHL				
	hierzu see	361 446 Sa					
1	Bestückte Leiterplatte PRINTED CIRCUIT BOARD	361 447	SCHL				
	hierzu see	361 447 Sa					
1	Bestückte Leiterplatte PRINTED CIRCUIT BOARD	361 448	SCHL				
	hierzu see	361 448 Sa					
1	Bestückte Leiterplatte PRINTED CIRCUIT BOARD	361 449	SCHL				
	hierzu see	361 449					

07				Schlumberger Meßgeräte GmbH Ingolstädter Straße 67 a 8000 München 46			Schaltteilliste EL. PARTS LIST		Liste besteht LIST CONSISTS aus OF Blatt 1 SHEETS
06									
05				1988	Tag DATE	Name NAME	Bezeichnung Schlumberger PART. NO. 210 041 Sa		Blatt Nr. SHEET NO 1
04				geschr.	3.5.	Staffler	Hierzu Schaltplan SEE CIRCUIT DIAGRAM 210 041 S		
03							Gerät: 4031		
02									
01									
	8089.69	27.5.88	SLM	Ausgabe ISSUE	Änd.-Mittg. MODIFIC. NO.	Tag DATE	Name NAME		

Diese Zeichnung ist unser Eigentum. Vervielfältigung, unbefugte Verwertung, Mitteilung an andere ist strafbar und schadenersatzpflichtig.

1	2	3	4	5	6	7	8
Pos. REF. NO.	Wert VALUE	Bezeichnung Schlumberger PART. NO.	Hersteller MANUFACT	Pos. REF. NO.	Wert VALUE	Bezeichnung Schlumberger PART. NO.	Hersteller MANUFACT
				C 22	47 pF ± 2 % 63 V-	810 512	STET
				C 23	47 pF ± 2 % 63 V-	810 512	STET
Bu 40		886 192	ROS	C 24	47 pF ± 2 % 63 V-	810 512	STET
Bu 41		886 192	ROS	C 25	47 pF ± 2 % 63 V-	810 512	STET
				C 26	47 pF ± 2 % 63 V-	810 512	STET
				C 27	47 pF ± 2 % 63 V-	810 512	STET
C 1	100 nF ± 10 % 50 V-	813 121	VIT	C 28	47 pF ± 2 % 63 V-	810 512	STET
C 2	10 µF ± 20 % 25 V-	814 076	MATSU	C 29	47 pF ± 2 % 63 V-	810 512	STET
C 3	100 nF ± 10 % 50 V-	813 121	VIT				
C 4	10 µF ± 20 % 25 V-	814 076	MATSU				
C 5	100 nF ± 10 % 50 V-	813 121	VIT				
C 6	10 µF ± 20 % 25 V-	814 076	MATSU				
				C 35	1 nF ± 5 % 50 V-	813 066	SIE
				C 36	1 nF ± 5 % 50 V-	813 066	SIE
C 10	47 pF ± 2 % 63 V-	810 512	STET	C 37	10 nF ± 10 % 50 V-	813 115	VIT
C 11	47 pF ± 2 % 63 V-	810 512	STET	C 38	1 nF ± 5 % 50 V-	813 066	SIE
C 12	47 pF ± 2 % 63 V-	810 512	STET				
C 13	47 pF ± 2 % 63 V-	810 512	STET	C 40	10 nF ± 10 % 50 V-	813 115	VIT
C 14	47 pF ± 2 % 63 V-	810 512	STET	C 41	10 nF ± 10 % 50 V-	813 115	VIT
				C 42	10 nF ± 10 % 50 V-	813 115	VIT
				C 46	10 nF ± 10 % 50 V-	813 115	VIT
C 20	47 pF ± 2 % 63 V-	810 512	STET	C 47	10 nF ± 10 % 50 V-	813 115	VIT
C 21	47 pF ± 2 % 63 V-	810 512	STET				

07				Schlumberger Meßgeräte GmbH Ingolstädter Straße 67 a 8000 München 46			Schaltteilliste EL. PARTS LIST Benennung DESCRIPTION Bestückte Leiterplatte Typ: DECADE SYNTHESE		Liste besteht LIST CONSISTS
06									
05								Blatt SHEETS	
04								Blatt Nr SHEET NO	
03									
02				1986	Tag DATE	Name NAME	Bezeichnung Schlumberger PART NO	361 403 Sa	1
01	7088.147	29.9.87	Staff	geschr	25.7.86	Dietrich	Hierzu Schaltplan SEE CIRCUIT DIAGRAM	210 041 S	
---	6088.27	9.10.86	DI	bearb.		<i>kg</i>	Gerät: 4031		
Ausgabe ISSUE	Änd.-Mittlg. Nr MODIFIC. NO.	Tag DATE	Name NAME	gdrf.					

Diese Zeichnung ist unser Eigentum. Vervielfältigung, unbefugte Verwertung, Mitteilung an andere ist strafbar und schadenersatzpflichtig

1	2	3	4	5	6	7	8
Pos. REF. NO	Wert VALUE	Bezeichnung Schlumberger PART. NO.	Hersteller MANUFACT	Pos. REF. NO.	Wert VALUE	Bezeichnung Schlumberger PART. NO.	Hersteller MANUFACT
C 50	10 nF ± 10 % 50 V-	813 115	VIT				
C 51	10 nF ± 10 % 50 V-	813 115	VIT	L 10	1,5 µH ± 10 %	821 124	GOW
C 52	10 nF ± 10 % 50 V-	813 115	VIT	L 11	1,5 µH ± 10 %	821 124	GOW
C 53	10 nF ± 10 % 50 V-	813 115	VIT				
				L 13	1,5 µH ± 10 %	821 124	GOW
				L 14	1,5 µH ± 10 %	821 124	GOW
				L 15	1,5 µH ± 10 %	821 124	GOW
				R 1	0 Ω	805 050	POL
				R 2	0 Ω	805 050	POL
				R 3	0 Ω	805 050	POL
C 60	10 nF ± 10 % 50 V-	813 115	VIT				
C 61	10 nF ± 10 % 50 V-	813 115	VIT				
C 62	10 nF ± 10 % 50 V-	813 115	VIT				
C 63	10 nF ± 10 % 50 V-	813 115	VIT				
C 64	10 nF ± 10 % 50 V-	813 115	VIT	St 54		884 508	PAN
C 65	10 nF ± 10 % 50 V-	813 115	VIT				
L 1	1,5 µH ± 10 %	821 124	GOW				
L 2	1,5 µH ± 10 %	821 124	GOW				
L 3	1,5 µH ± 10 %	821 124	GOW				
L 4	1,5 µH ± 10 %	821 124	GOW				
L 5	1,5 µH ± 10 %	821 124	GOW				
L 6	1,5 µH ± 10 %	821 124	GOW				
L 7	1,5 µH ± 10 %	821 124	GOW				

07				Schlumberger Meßgeräte GmbH Ingolstädter Straße 67 a 8000 München 46			Schaltteilliste EL. PARTS LIST		Liste besteht LIST CONSISTS		
06			Benennung DESCRIPTION							Bestückte Leiterplatte Typ: DECADE SYNTHESE	
05							Bezeichnung Schlumberger PART. NO		361 403 Sa		Blatt SHEETS
04							Hierzu Schaltplan SEE CIRCUIT DIAGRAM		210 041 S		Blatt Nr. SHEET NO
03				Ausgabe ISSUE		6088.27		2			
02				And.-Mittlg. Nr		9.10.86					
01	7088.28	6.7.87	St. P.	1986	Tag DATE	Name NAME	geschr.	25.7.86	Dietrich		
							bearb.		<i>He</i>		
							gepr.				
							Gerät:	4031			

Diese Zeichnung ist unser Eigentum. Vervielfältigung, unbefugte Verwertung, Mitteilung an andere ist strafbar und schadenersatzpflichtig

1	2	3	4	5	6	7	8
Pos REF. NO.	Wert VALUE	Bezeichnung Schlumberger PART NO.	Hersteller MANUFACT	Pos REF. NO.	Wert VALUE	Bezeichnung Schlumberger PART. NO	Hersteller MANUFACT
A 1	ME 5534 AD	834 209	VAL	C 21	47 nF ± 10 % 50 V-	813 371	VAL
A 2	MSA - 0385	834 216	AVANT	C 22	47 nF ± 10 % 50 V-	813 371	VAL
A 3	MSA - 0385	834 216	AVANT	C 23	47 µF ± 20 % 16 V-	814 386	RÖD
				C 24	1 nF ± 10 % 50 V-	813 247	VAL
				C 25	100 nF ± 10 % 50 V-	813 375	VAL
				C 26	10 pF ± 5 % 50 V-	813 223	VAL
C 1	10 µF ± 20 % 16 V-	814 382	RÖD				
C 2	100 nF ± 10 % 50 V-	813 375	VAL	C 29	10 nF ± 10 % 50 V-	813 332	VAL
C 3	2,2 µF ± 20 % 50 V-	814 362	RÖD	C 30	39 pF ± 5 % 50 V-	813 230	VAL
C 4	10 µF ± 20 % 16 V-	814 382	RÖD	C 31	47 pF ± 5 % 50 V-	813 231	VAL
C 5	100 nF ± 10 % 50 V-	813 375	VAL				
C 6	100 nF ± 10 % 50 V-	813 375	VAL	C 33	10 nF ± 10 % 50 V-	813 332	VAL
				C 34	10 µF ± 20 % 16 V-	814 382	RÖD
				C 35	1 nF ± 5 % 50 V-	813 247	VAL
				C 36	1 nF ± 5 % 50 V-	813 247	VAL
C 10	10 µF ± 20 % 16 V-	814 382	RÖD	C 37	1 nF ± 5 % 50 V-	813 247	VAL
C11	100 nF ± 10 % 50 V-	813 375	VAL	C 38	33 pF ± 5 % 50 V-	813 229	VAL
C 12	1 nF ± 5 % 50 V-	813 247	VAL	C 39	10 µF ± 20 % 16 V-	814 382	RÖD
C 13	1 nF ± 5 % 50 V-	813 247	VAL	C 40	10 nF ± 10 % 50 V-	813 332	VAL
C 14	4,7 nF ± 5 % 50 V-	813 255	VAL	C 41	1 nF ± 5 % 50 V-	813 247	VAL
C 15	4,7 nF ± 5 % 50 V-	813 255	VAL	C 42	10 nF ± 10 % 50 V-	813 332	VAL
C 16	10 nF ± 10 % 50 V-	813 332	VAL	C 43	1 nF ± 5 % 50 V-	813 247	VAL
C 17	47 pF ± 5 % 50 V-	813 231	VAL	C 44	18 pF ± 5 % 50 V-	813 226	VAL
C 18	10 nF ± 10 % 50 V-	813 332	VAL				
C 19	100 nF ± 10 % 50 V-	813 375	VAL				
C 20	470 nF ± 10 % 50 V-	813 383	VAL				

07				Schlumberger Meßgeräte GmbH Ingolstädter Straße 67a 8000 München 46			Schaltteilliste EL. PARTS LIST Bestückte Leiterplatte Typ: 200 kHz-DECADE		Liste besteht LIST CONSISTS	
06			Benennung DESCRIPTION						aus OF	3
05							Bezeichnung Schlumberger PART NO		Blatt SHEETS	
04							361 445 Sa		Blatt Nr SHEET NO	
03	7088.147	28.9.87	Staff	1986	Tag DATE	Name NAME	Hierzu Schaltplan SEE CIRCUIT DIAGRAM			
02	7088.127	31.8.87	Dj	geschr.	13.10.86	Dietrich	210 041 S			
01	7088.77	30.6.87	ca	bearb.			Gerät: 4031			
→	6088.27	14.10.86	ca	gepr.						
Ausgabe ISSUE	Änd.-Mittg Nr MODIFIC. NO	Tag DATE	Name NAME							

Diese Zeichnung ist unser Eigentum. Vervielfältigung, unbefugte Verwertung, Mitteilung an andere ist strafbar und schädnersatzpflichtig.



1	2	3	4	5	6	7	8
Pos. REF. NO.	Wert VALUE	Bezeichnung Schlumberger PART. NO.	Hersteller MANUFACT	Pos. REF. NO.	Wert VALUE	Bezeichnung Schlumberger PART. NO.	Hersteller MANUFACT
				L 3	10 $\mu$ H $\pm$ 10 %	821 239	STET
				L 4	1 $\mu$ H $\pm$ 5 %	821 227	STET
D 1	MC 120 13 P	834 385	NOT	L 5	1 $\mu$ H $\pm$ 5 %	821 227	STET
D 2	MC 145 158 P 1	834 408	NOT	L 6	120 nH $\pm$ 5 %	821 216	STET
G1 1	BAS 16	830 552	VAL	R 1	56 $\Omega$ $\pm$ 2 %	804 722	VAL
G1 2	LSS 250	856 200	SIE	R 2	1 k $\Omega$ $\pm$ 2 %	804 737	VAL
G1 3	BAS 16	830 552	VAL	R 3	6,8 k $\Omega$ $\pm$ 2 %	804 747	VAL
G1 4	BAS 16	830 552	VAL	R 4	680 $\Omega$ $\pm$ 2 %	804 735	VAL
G1 5	BAS 16	830 552	VAL	R 5	1,5 k $\Omega$ $\pm$ 2 %	804 739	VAL
				R 6	10 k $\Omega$ $\pm$ 2 %	804 749	VAL
				R 7	1,5 k $\Omega$ $\pm$ 2 %	804 739	VAL
G1 8	BB 609 A	830 621	SIE	R 8	15 k $\Omega$ $\pm$ 2 %	804 751	VAL
G1 9	BB 609 A	830 621	SIE	R 9	100 $\Omega$ $\pm$ 2 %	804 725	VAL
G1 10	BB 609 A	830 621	SIE	R 10	8,2 k $\Omega$ $\pm$ 2 %	804 748	VAL
G1 11	BB 609 A	830 621	SIE	R 11	8,2 k $\Omega$ $\pm$ 2 %	804 748	VAL
G1 12	BB 609 A	830 621	SIE	R 12	27 k $\Omega$ $\pm$ 2 %	804 754	VAL
G1 13	BB 609 A	830 621	SIE	R 13	27 k $\Omega$ $\pm$ 2 %	804 754	VAL
G1 14	BB 609 A	830 621	SIE	R 14	330 k $\Omega$ $\pm$ 2 %	804 767	VAL
G1 15	BB 609 A	830 621	SIE	R 15	330 k $\Omega$ $\pm$ 2 %	804 767	VAL
				R 16	50 k $\Omega$ $\pm$ 25 %	807 742	BOUR
L 1	1,2 $\mu$ H	821 228	STET				
L 2	38 nH ; 3,5 Wdg.	821 921	NEO				

07				Schlumberger Meßgeräte GmbH Ingolstädter Straße 67 a 8000 München 46			Schaltteilliste EL. PARTS LIST Bestückte Leiterplatte Typ: 200 kHz-DECADE		Liste besteht LIST CONSISTS		
06			Benennung DESCRIPTION						aus OF	3	
05			Bezeichnung Schlumberger PART NO						Blatt SHEETS		
04			Hierzu Schaltplan SEE CIRCUIT DIAGRAM						Blatt Nr SHEET NO		
03				Bezeichnung Schlumberger PART NO		361 445 Sa		2			
02	7088.127	31.8.87	1986	Tag DATE	Name NAME	210 041 S					
01	7088.27	30.6.87	gesch.	13.10.86	Dietrich	Gerät: 4031					
Ausgabe ISSUE	And-Mittig Nr MODIFIC. NO.	Tag DATE	Name NAME	bearb.	gepr.						
	6088.27	14.10.86									

Diese Zeichnung ist unser Eigentum. Vervielfältigung, unbefugte Verwertung, Mitteilung an andere ist strafbar und schadenersatzpflichtig

1	2	3	4	5	6	7	8
Pos. REF. NO.	Wert VALUE	Bezeichnung Schlumberger PART. NO.	Hersteller MANUFACT	Pos. REF. NO.	Wert VALUE	Bezeichnung Schlumberger PART. NO.	Hersteller MANUFACT
R 20	100 kΩ ± 2 %	804 761	VAL	R 47	2,2 kΩ ± 2 %	804 741	VAL
R 21	15 kΩ ± 2 %	804 751	VAL	R 48	4,7 kΩ ± 2 %	804 745	VAL
R 22	1,2 kΩ ± 2 %	804 738	VAL				
R 23	10 kΩ ± 2 %	804 749	VAL				
R 24	10 kΩ ± 2 %	804 749	VAL				
R 25	10 kΩ ± 2 %	804 749	VAL				
				T 1	BC 860 B	832 285	VAL
				T 2	BC 850 B	832 284	VAL
R 30	10 kΩ ± 2 %	804 749	VAL	T 3	BFR 93 A	832 287	VAL
R 31	56 Ω ± 2 %	804 722	VAL	T 4	BC 850 B	832 284	VAL
R 32	1 kΩ ± 2 %	804 737	VAL				
R 33	120 Ω ± 2 %	804 726	VAL	T 6	BC 850 B	832 284	VAL
R 34	47 Ω ± 2 %	804 721	VAL	T 7	BC 850 B	832 284	VAL
R 35	120 Ω ± 2 %	804 726	VAL				
R 40	330 Ω ± 2 %	804 731	VAL				
R 41	330 Ω ± 2 %	804 731	VAL				
R 45	8,2 kΩ ± 2 %	804 748	VAL				
R 46	5,6 kΩ ± 2 %	804 746	VAL				
07				<b>Schaltteilliste</b> EL. PARTS LIST Benennung DESCRIPTION <b>Bestückte Leiterplatte</b> Typ: 200 kHz-DECADE			Liste besteht LIST CONSISTS
06							aus OF
05							3
04							Blatt SHEETS
03							
02	7088.77	30.6.87	Lei	1986	Tag DATE	Name NAME	Bezeichnung Schlumberger PART. NO.
01	7088.7	12.1.87	Lei	1986			361 445 Sa
	6088.27	14.10.86	Lei	geschr.	13.10.86	Dietrich	
Ausgabe ISSUE	Änd.-Mittig. Nr. MODIFIC. NO.	Tag DATE	Name NAME	bearb. gpr			Hierzu Schaltplan SEE CIRCUIT DIAGRAM
							210 041 S
							Gerät: 4031

Diese Zeichnung ist unser Eigentum. Vervielfältigung, unbefugte Verwendung, Mitteilung an andere ist strafbar und schadenersatzpflichtig.

1	2	3	4	5	6	7	8
Pos. REF. NO.	Wert VALUE	Bezeichnung Schlumberger PART. NO.	Hersteller MANUFACT	Pos. REF. NO.	Wert VALUE	Bezeichnung Schlumberger PART. NO.	Hersteller MANUFACT
C 1	100 nF ± 10 % 50 V-	813 375	VAL	R 1	27 kΩ ± 2 %	804 754	VAL
C 2	10 nF ± 10 % 50 V-	813 332	VAL	R 2	2,7 kΩ ± 2 %	804 742	VAL
C 3	1 nF ± 10 % 50 V-	813 320	VAL	R 3	1,2 kΩ ± 2 %	804 738	VAL
C 4	10 nF ± 10 % 50 V-	813 332	VAL	R 4	100 Ω ± 2 %	804 725	VAL
C 5	100 nF ± 10 % 50 V-	813 375	VAL	R 5	1 kΩ ± 2 %	804 737	VAL
C 6	1 nF ± 10 % 50 V-	813 320	VAL	R 6	100 Ω ± 2 %	804 725	VAL
C 7	10 nF ± 10 % 50 V-	813 332	VAL				
C 10	10 nF ± 10 % 50 V-	813 332	VAL	R 10	68 Ω ± 2 %	804 723	VAL
C 11	39 pF ± 5 % 50 V-	813 230	VAL	R 11	1,5 kΩ ± 2 %	804 739	VAL
C 12	1 nF ± 10 % 50 V-	813 320	VAL	R 12	100 Ω ± 2 %	804 725	VAL
C 13	4,7 pF ± 0,25 pF 50 V-	813 219	VAL	R 13	1,8 kΩ ± 2 %	804 740	VAL
C 14	4,7 pF ± 0,25 pF 50 V-	813 219	VAL	R 14	22 Ω ± 2 %	804 717	VAL
				R 15	56 Ω ± 2 %	804 722	VAL
D 1	PC 74 HCT 74 T	834 433	VAL	T 1	BC 850 B	832 284	VAL
				T 2	BFR 93 A	832 287	VAL
L 1	10 nH ± 20 %	821 207	STET				

07										<b>Schalteilliste</b> EL. PARTS LIST Benennung DESCRIPTION Bestückte Leiterplatte Typ: 10 MHz DIVIDER Bezeichnung Schlumberger 361 446 Sa PART. NO Hierzu Schaltplan SEE CIRCUIT DIAGRAM 210 041 S Gerät: 4031	Liste besteht LIST CONSISTS aus OF 1 Blatt SHEETS Blatt Nr. SHEET NO 1
06											
05											
04											
03											
02	7088.144	24.9.87	Di								
01	7088.48	9.4.87	Di	1987	Tag DATE	Name NAME					
				geschr.	9.4.87	Dietrich					
Ausgabe ISSUE	Änd.-Mittig Nr. MODIFIC. NO	Tag DATE	Name NAME	bearb 99%							

Diese Zeichnung ist unser Eigentum. Vervielfältigung, unbefugte Verwertung, Mitteilung an andere ist strafbar und schadenersatzpflichtig.

1	2	3	4	5	6	7	8
Pos REF NO	Wert VALUE	Bezeichnung Schlumberger PART NO	Hersteller MANUFACT	Pos REF NO	Wert VALUE	Bezeichnung Schlumberger PART NO	Hersteller MANUFACT
C 1	1 nF ± 5 % 50 V-	813 247	VAL				
C 2	10 nF ± 10 % 50 V-	813 332	VAL				
C 3	10 nF ± 10 % 50 V-	813 332	VAL	L 1	680 nH ± 5 %	821 225	STET
C 4	1 nF ± 5 % 50 V-	813 247	VAL	L 2	82 nH ± 5 %	821 214	STET
C 5	390 pF ± 5 % 50 V-	813 242	VAL	L 3	82 nH ± 5 %	821 214	STET
C 6	220 pF ± 5 % 50 V-	813 239	VAL	L 4	82 nH ± 5 %	821 214	STET
C 7	18 pF ± 5 % 50 V-	813 226	VAL	L 5	82 nH ± 5 %	821 214	STET
C 8	47 pF ± 5 % 50 V-	813 231	VAL	L 6	1,2 µH ± 5 %	821 228	STET
C 9	56 pF ± 5 % 50 V-	813 232	VAL	L 7	10 µH ± 10 %	821 239	STET
C 10	82 pF ± 5 % 50 V-	813 234	VAL	L 8	1,2 µH ± 5 %	821 228	STET
C 11	680 pF ± 5 % 50 V-	813 245	VAL				
C 12	1 nF ± 5 % 50 V-	813 247	VAL				
C 13	1 nF ± 5 % 50 V-	813 247	VAL				
C 14	10 nF ± 10 % 50 V-	813 332	VAL				
C 15	39 pF ± 5 % 50 V-	813 230	VAL	Mi 1	SMD-C 1	872 081	SYN
C 16	68 pF ± 5 % 50 V-	813 233	VAL	Mi 2	SMD-C 1	872 081	SYN
C 17	39 pF ± 5 % 50 V-	813 230	VAL				
C 18	1 nF ± 10 % 50 V-	813 320	VAL				
C 19	1 nF ± 5 % 50 V-	813 247	VAL				
C 20	1 nF ± 10 % 50 V-	813 320	VAL				
C 21	2,2 nF ± 5 % 50 V-	813 251	VAL	R 1	2,2 Ω ± 5 %	804 706	VAL
C 22	10 nF ± 10 % 50 V-	813 332	VAL	R 2	27 Ω ± 2 %	804 718	VAL
C 23	1 nF ± 10 % 50 V-	813 320	VAL	R 3	330 Ω ± 2 %	804 731	VAL
				R 4	12 kΩ ± 2 %	804 750	VAL
				R 5	1,2 kΩ ± 2 %	804 738	VAL
				R 6	270 Ω ± 2 %	804 730	VAL
				R 7	270 Ω ± 2 %	804 730	VAL

07				Schlumberger Meßgeräte GmbH Ingolstädter Straße 67 a 8000 München 46			Schaltteilliste EL. PARTS LIST		Liste besteht LIST CONSISTS
06									
05									2
04									Blatt SHEETS
03									
02									
01	8088.204	28.10.88	Staff	1986	Tag DATE	Name NAME	Bezeichnung Schlumberger PART NO	361 447 Sa	Blatt Nr SHEET NO
-	6089.27		geschr	13.10.86		Dietrich			1
Aus- gabe ISSUE	Änd- Nr MODIFIC NO	Tag DATE	Name NAME	bearb gepr			Hierzu Schaltplan SEE CIRCUIT DIAGRAM	210 041 S	
							Gerät: 4031		

Diese Zeichnung ist unser Eigentum. Vervielfältigung, unbefugte Verwertung, Mitteilung an andere ist strafbar und schadenersatzpflichtig.

1	2	3	4	5	6	7	8
Pos. REF. NO.	Wert VALUE	Bezeichnung Schlumberger PART. NO.	Hersteller MANUFACT	Pos. REF. NO.	Wert VALUE	Bezeichnung Schlumberger PART. NO.	Hersteller MANUFACT
R 8	18 Ω ± 2%	804 716	VAL				
R 10	120 Ω ± 2%	804 726	VAL				
R 11	120 Ω ± 2%	804 726	VAL				
R 13	47 Ω ± 2%	804 721	VAL	T 1	BFS 19 GEG	832 286	VAL
R 14	4,7 Ω ± 5%	804 709	VAL	T 2	BFR 93 A GEG	832 287	VAL
R 15	22 Ω ± 2%	804 717	VAL	T 3	BC 850 B GEG	832 284	VAL
R 16	1,8 kΩ ± 2%	804 740	VAL	T 4	BFR 93 A GEG	832 287	VAL
R 17	390 Ω ± 2%	804 732	VAL	T 5	BFR 93 A GEG	832 287	VAL
R 18	18 kΩ ± 2%	804 752	VAL	T 6	BC 860 B	832 285	VAL
R 19	270 Ω ± 2%	804 730	VAL				
R 20	18 Ω ± 2%	804 716	VAL				
R 21	270 Ω ± 2%	804 730	VAL				
R 22	4,7 kΩ ± 2%	804 745	VAL				
R 23	15 kΩ ± 2%	804 751	VAL				
R 24	10 kΩ ± 2%	804 749	VAL				
R 25	1 kΩ ± 2%	804 737	VAL				
R 26	27 kΩ ± 2%	804 754	VAL				
R 27	1 kΩ ± 2%	804 737	VAL				
R 28	10 Ω ± 2%	804 713	VAL				
R 29	10 Ω ± 2%	804 713	VAL				
R 31	330 Ω ± 2%	804 731	VAL				
R 32	15 kΩ ± 2%	804 751	VAL				
R 33	330 Ω ± 2%	804 731	VAL				

07				Schlumberger Meßgeräte GmbH Ingolstädter Straße 67a 8000 München 46			Schaltteilliste EL. PARTS LIST Bestückte Leiterplatte Typ: MIXER-FILTER		Liste besteht LIST CONSISTS
06			Benennung DESCRIPTION						
05				1986			Bezeichnung Schlumberger PART. NO		Blatt SHEETS
04				Tag DATE	Name NAME	361 447 Sa		Blatt Nr. SHEET NO	
03	8088.204	28.10.88	Staff	geschr	13.10.86	Dietrich		2	
02	7088.70	4.6.87	Staff	bearb.		Hierzu Schaltplan SEE CIRCUIT DIAGRAM			
01	6088.35	20.10.86	Pa	gepr.		210 041 S			
-	6088.27		Pa			Gerät: 4031			
Ausgabe ISSUE	Änd.-Mitgl. Nr. MODIFIC. NO.	Tag DATE	Name NAME						

Diese Zeichnung ist unser Eigentum. Vervielfältigung, unbefugte Verwertung, Mitteilung an andere ist strafbar und schadenersatzpflichtig

1	2		3		4	5	6		7		8
Pos. REF. NO.	Wert VALUE		Bezeichnung Schlumberger PART. NO.		Hersteller MANUFACT	Pos. REF. NO.	Wert VALUE		Bezeichnung Schlumberger PART. NO.		Hersteller MANUFACT
C 1	2...18 pF		817 059		VAL						
C 2	4,7 pF ± 0,25 pF 50V-		813 219		VAL	C 29	39 pF ± 5 % 50 V-		813 230		VAL
C 3	8,2 pF ± 0,25 pF 50V-		813 222		VAL	C 30	10 nF ± 10 % 50 V-		813 332		VAL
C 4	2,2 pF ± 0,25 pF 50V-		813 215		VAL	C 31	10 nF ± 10 % 50 V-		813 332		VAL
C 5	100 nF ± 10 % 50 V-		813 375		VAL	C 32	33 pF ± 5 % 50 V-		813 229		VAL
C 6	100 nF ± 10 % 50 V-		813 375		VAL						
C 7	100 nF ± 10 % 50 V-		813 375		VAL						
C 8	100 nF ± 10 % 50 V-		813 375		VAL						
C 10	10 nF ± 10 % 50 V-		813 332		VAL						
C 11	3,3 pF ± 0,25 pF 50 V-		813 217		VAL						
C 12	2,7 pF ± 0,25 pF 50 V-		813 216		VAL						
C 13	3,3 pF ± 0,25 pF 50 V-		813 217		VAL						
C 14	33 pF ± 5 % 50 V-		813 229		VAL						
C 15	5,6 pF ± 0,25 pF 50 V-		813 220		VAL	GI 1	BBY 31		830 618		VAL
C 16	10 pF ± 20 % 16 V-		814 382		RÖD	GI 2	BBY 31		830 618		VAL
C 17	10 pF ± 20 % 16 V-		814 382		RÖD	GI 3	BBY 31		830 618		VAL
C 18	5,6 pF ± 0,25 pF 50 V-		813 220		VAL	GI 4	BBY 31		830 618		VAL
C 19	10 nF ± 10 % 50 V-		813 332		VAL	GI 5	BBY 31		830 618		VAL
C 20	10 nF ± 10 % 50 V-		813 332		VAL	GI 6	BBY 31		830 618		VAL
C 21	10 nF ± 10 % 50 V-		813 332		VAL						
C 22	10 nF ± 10 % 50 V-		813 332		VAL						
C 23	33 pF ± 5 % 50 V-		813 229		VAL						
C 24	33 pF ± 5 % 50 V-		813 229		VAL						
C 25	100 nF ± 10 % 50 V-		813 375		VAL						
C 27	6,8 pF ± 0,25 pF 50 V-		813 221		VAL						
07			Schlumberger Meßgeräte GmbH Ingolstädter Straße 67a 8000 München 46			Schaltteilliste EL. PARTS LIST Benennung DESCRIPTION <b>Bestückte Leiterplatte</b> Typ: Oscillator					Liste besteht LIST CONSISTS
06											
05									Blatt SHEETS		
04	8088.78	18.5.88				Mo.			Blatt Nr. SHEET NO.		
03	7088.128	1.9.87	Di			1					
02	7088.63	15.5.87	Di	1986	Tag DATE	Bezeichnung Schlumberger PART. NO.					
01	6088.75	15.12.86	Di	1986	Name NAME	361 448 Sa					
--	6088.27	13.10.86	Di	geschr	16.9.86	Hierzu Schaltplan SEE CIRCUIT DIAGRAM					
Ausgabe ISSUE	Änd.-Mittig. Nr. MODIFIC. NO.	Tag DATE	Name NAME	bearb. gedr.		210 041 S					
						Gerät: 4031					

Diese Zeichnung ist unser Eigentum. Vervielfältigung, unbefugte Verwertung, Mitteilung an andere ist strafbar und schadenersatzpflichtig.

1	2			3		4	5	6		7		8
Pos. REF. NO.	Wert VALUE			Bezeichnung Schlumberger PART. NO.		Hersteller MANUFACT	Pos. REF. NO.	Wert VALUE		Bezeichnung Schlumberger PART. NO.		Hersteller MANUFACT
L 1	1,2 µH ± 5 %			821 228		STET	R 15	330 Ω ± 2 %		804 731		VAL
L 2	1,2 µH ± 5 %			821 228		STET	R 16	5,6 Ω ± 2 %		804 710		VAL
L 3	1,5 µH ± 10 %			821 229		STET	R 17	2,2 kΩ ± 2 %		804 741		VAL
L 4	1,2 µH ± 5 %			821 228		STET	R 18	1,8 kΩ ± 2 %		804 740		VAL
L 5	1,2 µH ± 5 %			821 228		STET	R 19	1,2 kΩ ± 2 %		804 738		VAL
L 6	1,2 µH ± 5 %			821 228		STET	R 20	560 Ω ± 2 %		804 734		VAL
L 7	10 nH ± 20 %			821 207		STET	R 21	2,2 kΩ ± 2 %		804 741		VAL
L 8	10 nH ± 20 %			821 207		STET						
L 10	1,2 µH ± 5 %			821 228		STET						
L 11	1,2 µH ± 5 %			821 228		STET	R 25	2,2 kΩ ± 2 %		804 741		VAL
L 12	10 nH ± 20 %			821 207		STET	T 1	BFR 93 A		832 287		VAL
							T 2	BFR 93 A		832 287		VAL
R 1	100 Ω ± 2 %			804 725		VAL	T 3	BFR 93 A		832 287		VAL
R 2	180 Ω ± 2 %			804 728		VAL	T 4	BFR 93 A		832 287		VAL
R 3	1,5 kΩ ± 2 %			804 739		VAL	T 5	BFR 93 A		832 287		VAL
R 4	1,8 kΩ ± 2 %			804 740		VAL	T 6	BC 850 B		832 284		VAL
R 5	1,5 kΩ ± 2 %			804 739		VAL	T 7	BC 850 B		832 284		VAL
R 6	15 kΩ ± 2 %			804 751		VAL	T 8	BC 860 B		832 285		VAL
R 7	1,5 kΩ ± 2 %			804 739		VAL	T 9	BC 860 B		832 285		VAL
R 8	15 kΩ ± 2 %			804 751		VAL						
R 9	150 Ω ± 2 %			804 727		VAL						
R 10	4,7 kΩ ± 2 %			804 745		VAL						
R 11	470 Ω ± 2 %			804 733		VAL						
R 12	330 Ω ± 2 %			804 731		VAL						
R 13	5,6 Ω ± 2 %			804 710		VAL						
R 14	2,2 kΩ ± 2 %			804 741		VAL						
07				Schlumberger Meßgeräte GmbH Ingolstädter Straße 67 a 8000 München 46			Schaltteilliste EL. PARTS LIST Benennung DESCRIPTION <b>Bestückte Leiterplatte Typ: Oscillator</b>					Liste besteht LIST CONSISTS aus OF 2 Blatt SHEETS
06												
05							geschr.	bearb.	gepr.	Gerät: 4031		
04							Ausgabe ISSUE	Änd.-Mittig Nr. MODIFIC. NO.	Tag DATE	Name NAME	7088.128	1.9.87
03				7088.63	15.5.87	Di	6088.31	16.10.86	Di	6088.27	13.10.86	Di

1	2	3	4	5	6	7	8
Pos. REF. NO.	Wert VALUE	Bezeichnung Schlumberger PART. NO.	Hersteller MANUFACT	Pos. REF. NO.	Wert VALUE	Bezeichnung Schlumberger PART. NO.	Hersteller MANUFACT
A 1	MC 3403 D	834 215	VAL	C 19	10 µF ± 20 % 16 V-	814 382	RÖD
A 2	TLC 271 A CD	834 221	TEX	C 20	100 pF ± 5 % 50 V-	813 235	VAL
A 3	RC 4560 H	834 210	RAYT	C 21	10 pF ± 5 % 50 V-	813 223	VAL
A 4	LM 319 D	834 214	VAL	C 22	330 pF ± 5 % 50 V-	813 241	VAL
A 5	LM 319 D	834 214	VAL	C 23	10 nF ± 10 % 50 V-	813 332	VAL
				C 24	220 nF ± 10 % 50 V-	813 379	VAL
				C 25	220 nF ± 10 % 50 V-	813 379	VAL
				C 26	220 nF ± 10 % 50 V-	813 379	VAL
				C 27	560 pF ± 5 % 50 V-	813 244	VAL
C 1	10 nF ± 10 % 50 V-	813 332	VAL				
C 2	100 nF ± 10 % 50 V-	813 375	VAL				
C 3	100 nF ± 10 % 50 V-	813 375	VAL	C 30	10 µF ± 20 % 16 V-	814 382	RÖD
C 4	10 nF ± 10 % 50 V-	813 332	VAL	C 31	220 nF ± 10 % 50 V-	813 379	VAL
C 5	100 nF ± 10 % 50 V-	813 375	VAL	C 32	68 pF ± 5 % 50 V-	813 233	VAL
C 6	100 nF ± 10 % 50 V-	813 375	VAL	C 33	330 pF ± 5 % 50 V-	813 241	VAL
C 7	47 µF ± 20 % 16 V-m	814 386	RÖD	C 34	330 pF ± 5 % 50 V-	813 241	VAL
				C 35	47 pF ± 5 % 50 V-	813 231	VAL
				C 36	10 nF ± 10 % 50 V-	813 332	VAL
C 10	100 nF ± 10 % 50 V-	813 375	VAL	C 37	39 pF ± 5 % 50 V-	813 230	VAL
C 11	100 nF ± 10 % 50 V-	813 375	VAL				
C 12	100 nF ± 10 % 50 V-	813 375	VAL				
C 13	100 nF ± 10 % 50 V-	813 375	VAL	C 40	120 pF ± 5 % 50 V-	813 236	VAL
C 14	100 nF ± 10 % 50 V-	813 375	VAL	C 41	100 pF ± 5 % 50 V-	813 235	VAL
C 15	1,5 µF ± 0 % 63 V-	812 349	RÖD	C 42	47 pF ± 5 % 50 V-	813 231	VAL
C 16	100 nF ± 10 % 50 V-	813 375	VAL	C 43	180 pF ± 5 % 50 V-	813 238	VAL
C 17	330 pF ± 5 % 50 V-	813 241	VAL	C 44	10 nF ± 10 % 50 V-	813 332	VAL
C 18	47 µF ± 20 % 16 V-	814 386	RÖD	C 45	100 nF ± 10 % 50 V-	813 375	VAL

07				Schlumberger Meßgeräte GmbH Ingolstädter Straße 67 a 8000 München 46			Schaltteilliste EL. PARTS LIST		Liste besteht LIST CONSISTS		
06			Benennung DESCRIPTION							Bestückte Leiterplatte Typ: Phase Detector	
05							Bezeichnung Schlumberger PART. NO.		361 449 Sa		5
04							Hierzu Schaltplan SEE CIRCUIT DIAGRAM		210 041 S		Blatt SHEETS
03				bearb.		Gerät: 4031		Blatt Nr. SHEET NO.			
02	2088,87	1.7.87	Po	1986	Tag DATE	Name NAME			1		
01	6088,35	20.10.86	Di	geschr.	18.9.86	Dietrich					
--	6088,27	14.10.86	Di	gedr.							
Aus- gabe ISSUE	Änd.-Mittig. Nr. MODIFIC. NO.	Tag DATE	Name NAME	gedr.							

Diese Zeichnung ist unser Eigentum. Vervielfältigung, unbefugte Verwertung, Mitteilung an andere ist strafbar und schadenersatzpflichtig.



1	2			3		4		5		6		7		8	
Pos. REF. NO.	Wert VALUE			Bezeichnung Schlumberger PART. NO.		Hersteller MANUFACT		Pos. REF. NO.	Wert VALUE			Bezeichnung Schlumberger PART. NO.		Hersteller MANUFACT	
								C 73	10 nF ± 10 % 50 V-			813 332		VAL	
								C 74	1 nF ± 10 % 50 V-			813 320		VAL	
C 48	12 pF ± 5 % 50 V-			813 224		VAL									
C 50	100 nF ± 10 % 50 V-			813 375		VAL		C 77	47 µF + 20 % 16 V-			814 386		RÖD	
C 51	470 pF ± 5 % 50 V-			813 243		VAL		C 78	47 µF + 20 % 16 V-			814 386		RÖD	
C 52	27 pF ± 5 % 50 V-			813 228		VAL									
C 53	1 nF ± 10 % 50 V-			813 320		VAL									
C 54	10 nF ± 10 % 50 V-			813 332		VAL									
C 56	100 nF ± 10 % 50 V-			813 375		VAL		D 1	PC 74 HCT 374 T			834 437		VAL	
								D 2	DAC 08 ED			834 136		VAL	
								D 3	DAC 08 ED			834 136		VAL	
								D 4	DG 211 CY			834 471		SILI	
C 60	10 nF ± 10 % 50 V-			813 332		VAL		D 5	PC 74 HCT 125 T			834 472		VAL	
C 61	470 nF ± 10 % 50 V-			813 383		VAL		D 6	PC 74 HC 03 T			834 480		VAL	
C 62	10 nF ± 10 % 50 V-			813 332		VAL									
C 63	10 nF ± 10 % 50 V-			813 332		VAL									
C 64	82 pF ± 5 % 50 V-			813 234		VAL		G1 1	HS MS 2910			830 551		HP	
C 65	100 pF ± 5 % 50 V-			813 235		VAL		G1 2	HS MS 2910			830 551		HP	
C 66	10 nF ± 10 % 50 V-			813 332		VAL		G1 3	BAS 19			830 553		VAL	
								G1 4	BAS 19			830 553		VAL	
C 69	100 nF ± 10 % 50 V-			813 375		VAL									
C 70	100 nF ± 10 % 50 V-			813 375		VAL									
C 72	100 nF ± 10 % 50 V-			813 375		VAL									

07				Schlumberger Meßgeräte GmbH Ingolstädter Straße 67 a 8000 München 46				Schaltteilliste EL. PARTS LIST Benennung DESCRIPTION Bestückte Leiterplatte Typ: Phase Detector				Liste besteht LIST CONSISTS	
06												aus OF	
05				1986				361 449 Sa				Blatt SHEETS	
04	8088.7	26.1.88	Staff									Tag DATE	
03	7088.147	28.9.87	Staff	geschr. 18.9.86 Dietrich				210 041 S				2	
02	7088.93	23.7.87	Staff										
01	7088.87	1.7.87	Po	gerpr.				Gerät: 4031					
	8088.27	14.10.86	Di										
Ausgabe ISSUE	And.-Mittg. Nr. MODIFIC. NO.	Tag DATE	Name NAME										

Diese Zeichnung ist unser Eigentum. Vervielfältigung, unbefugte Verwertung, Mitteilung an andere ist strafbar und schadenersatzpflichtig.

1	2	3	4	5	6	7	8
Pos. REF. NO.	Wert VALUE	Bezeichnung Schlumberger PART NO.	Hersteller MANUFACT	Pos. REF. NO.	Wert VALUE	Bezeichnung Schlumberger PART. NO.	Hersteller MANUFACT
				R 5	2,2 kΩ ± 2%	804 741	VAL
L 1	220 nH ± 5%	821 219	STET	R 6	10 kΩ ± 2%	804 749	VAL
L 2	HF - Spule HF - COIL	394 397	SCHL				
L 3	HF - Spule HF - COIL	394 395	SCHL				
L 4	1,5 μH ± 10%	821 229	STET				
L 5	1,5 μH ± 10%	821 229	STET	R 10	4,7 kΩ ± 2%	804 745	VAL
L 6	HF - Spule HF - COIL	394 397	SCHL	R 11	10 kΩ ± 2%	804 749	VAL
L 7	470 nH ± 5%	821 223	STET	R 12	2,2 kΩ ± 2%	804 741	VAL
				R 13	12 kΩ ± 2%	804 750	VAL
				R 14	10 kΩ ± 2%	804 749	VAL
L 10	120 nH ± 5%	821 216	STET	R 15	5 kΩ ± 25%	807 739	BOURB
L 11	1 μH ± 5%	821 227	STET	R 16	1 kΩ ± 2%	804 737	VAL
L 12	120 nH ± 5%	821 216	STET				
				R 18	12 kΩ ± 2%	804 750	VAL
				R 19	12 kΩ ± 2%	804 750	VAL
				R 20	10 kΩ ± 2%	804 749	VAL
				R 21	3,3 kΩ ± 2%	804 743	VAL
M 1	SMD - C 1	872 081	SYNER	R 22	3,3 kΩ ± 2%	804 743	VAL
M 2	SMD - C 1	872 081	SYNER	R 23	33 kΩ ± 2%	804 755	VAL
				R 24	330 kΩ ± 2%	804 767	VAL
				R 25	20 kΩ ± 25%	807 741	BOURB
				R 26	4,7 kΩ ± 2%	804 745	VAL
				R 27	10 kΩ ± 2%	804 749	VAL
R 1	10 kΩ ± 2%	804 749	VAL	R 28	15 kΩ ± 2%	804 751	VAL
R 2	10 kΩ ± 2%	804 749	VAL				
R 3	10 kΩ ± 2%	804 749	VAL	R 30	22 Ω ± 2%	804 717	VAL

07				Schlumberger Meßgeräte GmbH Ingolstädter Straße 67a 8000 München 46			Schaltteilliste EL. PARTS LIST Bestückte Leiterplatte Typ: Phase Detector		Liste besteht LIST CONSISTS aus OF 5 Blatt SHEETS
06									
05				1986			Bezeichnung Schlumberger PART. NO. 361 449 Sa		Blatt Nr. SHEET NO. 3
04	9088.56	23.8.88	26						
03	8088.76	2.2.88	Pa	geschr.	18.9.86	Dietrich	Gerät: 4037		
02	7088.87	1.7.87	Po	bearb.					
01	7088.7	12.1.87	Lei	gepr.					
—	6088.27	14.10.86	Di						
Ausgabe ISSUE	Änd. Mittlg. MODIFIC. NO.	Tag DATE	Name NAME						

Diese Zeichnung ist unser Eigentum. Vervielfältigung, unbefugte Verwertung, Mitteilung an andere ist strafbar und schadenersatzpflichtig.

1	2	3	4	5	6	7	8
Pos. REF. NO.	Wert VALUE	Bezeichnung Schlumberger PART. NO.	Hersteller MANUFACT	Pos. REF. NO.	Wert VALUE	Bezeichnung Schlumberger PART. NO.	Hersteller MANUFACT
R 31	180 Ω ± 2 %	804 728	VAL				
R 32	4,7 kΩ ± 2 %	804 745	VAL				
R 33	33 kΩ ± 2 %	804 755	VAL	R 60	100 Ω ± 2 %	804 725	VAL
R 34	220 Ω ± 2 %	804 729	VAL	R 61	330 Ω ± 2 %	804 731	VAL
R 35	12 kΩ ± 2 %	804 750	VAL	R 62	5,6 kΩ ± 2 %	804 746	VAL
R 36	1,8 kΩ ± 2 %	804 740	VAL	R 63	1 kΩ ± 2 %	804 737	VAL
				R 64	22 Ω ± 2 %	804 717	VAL
				R 65	68 Ω ± 2 %	804 723	VAL
				R 66	1 kΩ ± 2 %	804 737	VAL
R 40	82 Ω ± 2 %	804 724	VAL				
R 41	4,7 kΩ ± 2 %	804 745	VAL				
R 42	1 kΩ ± 2 %	804 737	VAL				
R 43	10 kΩ ± 2 %	804 749	VAL	R 70	100 Ω ± 2 %	804 725	VAL
R 44	3,3 kΩ ± 2 %	804 743	VAL	R 71	56 Ω ± 2 %	804 722	VAL
R 45	47 kΩ ± 2 %	804 757	VAL	R 72	47 Ω ± 2 %	804 721	VAL
R 46	470 kΩ ± 2 %	804 769	VAL	R 73	100 Ω ± 2 %	804 725	VAL
				R 74	47 Ω ± 2 %	804 721	VAL
				R 75	39 Ω ± 2 %	804 720	VAL
				R 76	330 Ω ± 2 %	804 731	VAL
R 50	22 kΩ ± 2 %	804 753	VAL				
R 51	12 kΩ ± 2 %	804 750	VAL				
R 52	22 kΩ ± 2 %	804 753	VAL				
R 53	4,7 kΩ ± 2 %	804 745	VAL	R 80	6,8 kΩ ± 2 %	804 747	VAL
R 54	20 kΩ ± 25 %	807 741	BOURN	R 81	10 kΩ ± 2 %	804 749	VAL
R 55	4,7 kΩ ± 2 %	804 745	VAL	R 82	39 Ω ± 2 %	804 720	VAL
R 56	39 Ω ± 2 %	804 720	VAL	R 83	47 Ω ± 2 %	804 721	VAL
R 57	1 kΩ ± 2 %	804 737	VAL	R 84	47 Ω ± 2 %	804 721	VAL

07				Schlumberger Meßgeräte GmbH Ingolstädter Straße 67 a 8000 München 46				Schaltteilliste EL. PARTS LIST		Liste besteht LIST CONSISTS aus OF 5 Blatt SHEETS
06										
05				1986		Name NAME		Bezeichnung Schlumberger PART NO		Blatt Nr SHEET NO 4
04				Tag DATE		Name NAME		361 449 Sa		
03	8088,141	2.9.888	Kr.	geschr. 18.9.86		Dietrich		Hierzu Schaltplan SEE CIRCUIT DIAGRAM		
02	7088,147	28.9.87	Staff	bearb.				210 041 S		
01	7088,87	1.7.87	Pa	gedr.				Gerät: 4031		
00	6088,27	14.10.86	Di							
Ausgabe ISSUE	Änd.-Mittig. Nr. MODIFIC. NO.	Tag DATE	Name NAME							

Diese Zeichnung ist unser Eigentum. Vervielfältigung, unbefugte Verwertung, Mitteilung an andere ist strafbar und schadenersatzpflichtig.

1	2	3	4	5	6	7	8
Pos. REF. NO.	Wert VALUE	Bezeichnung Schlumberger PART. NO.	Hersteller MANUFACT	Pos. REF. NO.	Wert VALUE	Bezeichnung Schlumberger PART. NO.	Hersteller MANUFACT
R 85	3,3 kΩ ± 2 %	804 743	VAL				
R 86	10 Ω ± 2 %	804 713	VAL				
R 88	10 kΩ ± 2 %	804 749	VAL				
R 89	1 kΩ ± 2 %	804 737	VAL				
R 90	68 Ω ± 2 %	804 723	VAL				
R 91	1 kΩ ± 2 %	804 737	VAL				
R 92	180 Ω ± 2 %	804 728	VAL				
R 93	6,8 kΩ ± 2 %	804 747	VAL				
T 1	BFR 93 A	832 287	VAL				
T 2	BFR 93 A	832 287	VAL				

07										
06										
05										
04	8088.175	29.9.88	Kr.	Schlumberger Meßgeräte GmbH Ingolstädter Straße 67a 8000 München 46			Schaltteilliste EL. PARTS LIST			Liste besteht LIST CONSISTS aus OF 5 Blatt SHEETS
03	8088.141	2.9.88	Kr.							
02	7088.147	28.9.87	Staff				Benennung DESCRIPTION			Bestückte Leiterplatte Typ: Phase Detector
01	7088.87	1.7.87	Po	1986	Tag DATE	Name NAME	Bezeichnung Schlumberger PART NO			
	6088.27	14.10.86	Di	geschr.	18.9.86	Dietrich	Hierzu Schaltplan SEE CIRCUIT DIAGRAM			210 041 S
Aus- gabe ISSUE	Änd- Nr. MODIFIC. NO.	Tag DATE	Name NAME	bearb. gedr.			Gerät: 4031			5

Diese Zeichnung ist unser Eigentum. Vervielfältigung, unbefugte Verwertung, Mitteilung an andere ist strafbar und schadenersatzpflichtig

### 1. Oscillator 361 436

The oscillator around T1 works as a negative-impedance oscillator and can be tuned in its frequency over more than one octave with varactors G14 and G15. The output power is regulated with a PIN-diode attenuator (G11, G12, G13) and amplified by T2. It is distributed via the Z/3 starpoint R36, R37, R40 to the programmable divider 361 439 and the UHF divider 361 435.

The actual value of the output power is obtained by the integral controller A1 by peak rectification of the RF signal following the amplifier with G16, C33. From comparison with the set value, which is determined by the voltage divider R33, R35, the controller determines what is applied to the PIN diodes.

### 2. UHF divider 361 435

On the UHF divider circuit board (361 435) the signal from the oscillator (between 500 and 1000 MHz in frequency), is filtered immediately or divided and filtered, so that frequencies between 125 and 1000 MHz appear on output Bu42 within an level range from -8 dBm to +2 dBm and with an harmonics ratio of  $\geq 35$  dBc.

If output frequency is greater than 500 MHz, the signal from the oscillator is undivided filtered. The appropriate lowpass filters are located on separate PCBs (361 437 for  $f = 740$  to 1000 MHz, 361 438 for  $f = 500$  to 740 MHz) on the surface of PCB 361 435.

If output frequency is smaller than 500 MHz, the oscillator frequency is divided by two in each of the dividers D1 and D2. The divided frequencies are fed to the appropriate lowpass filters via switch D3. There are three lowpass filters for the bands 125-200 MHz (L15-L19), 200-320 MHz (L10-L14) and 320-500 MHz (L5-L9).

Ref.No. 213 041 F	Sub UHF Synthesizer	Date
Type 4031	Unit	Sheet 1/2
Schlumberger		Functional Description

### 3. Programmable divider 361 439

The oscillator frequency is exactly regulated in the range from 480 to 1020 MHz to the set value by a PLL. For this purpose the reference frequency of 500 MHz on Bu41 is divided to 250 MHz, 100 MHz and 50 MHz in D1, D2 and D3. Either 500 MHz or 250 MHz is down-converted with 100 MHz or 50 MHz by mixer Mi1. The amplified mixture product results in either 50 MHz, 60 MHz, 70 MHz, 80 MHz or 90 MHz on the output of divider D10, depending on the setting of D4.

On mixer Mi2, which functions as a phase detector, a phase comparison of the divided reference frequency (50, 60, 70, 80, 90 MHz) with the correspondingly divided oscillator frequency produces the necessary oscillator control voltage at Bu19. So that the PLL can capture over the entire frequency range, a DC voltage is superimposed on the mixer. This fine-tuning voltage is derived in the capture circuit (voltage tracking) with ICs A1, A2, A3, A4 and D14. On D14 the reference frequency, divided to 5 MHz, is compared to the divided oscillator frequency. If there is a large difference in frequency, A4/A causes transistor T14 to conduct. Thus integrator A2 is connected to the output of IC A4/B. This draws integrator A2 in the appropriate direction. The voltage tracking on the mixer is by feedback R82. In the range 4.8 to 5.4 MHz A3 causes transistor T14 to conduct via T15. In the control range of the mixer T14 goes high-impedance and the voltage tracking is then via A1, A2 and draws the mixer to the centre of the control range. The lowpass filter (L12-L15, C43-C50) at the output of Mi2 suppresses interference that is higher in frequency (eg 5 MHz) on the control line.

The output frequency is set in increments of 100 MHz via the programmable TTL divider D13. Frequency increments of 20 MHz are produced by driving the ICs D15, D16, D21 and D22. Here the duty cycle of the 5 MHz is altered (output D13) and applied to the control input of the dual-modulus divider D11. Smaller frequency increments are set by way of the reference frequency.

The capture range of the circuit is adjusted with R121. Transistor T20 signals H level on Bu10 if the circuit is out of synchronism.

Ref.No. 213 041 F	Sub UHF Synthesizer	Date
Type 4031	Unit	Sheet 2/2
Schlumberger		Functional Description

Necessary Equipment	Measuring Procedure	Measuring Point	Frequency	Adjustment	Set Value	Actual Value	Revision History				Sheet	
							Issue	Date	Name	Alteration No.		Sub Unit
4031 DVM  4031 Spectrum analyzer	1. <u>UHF divider 361 435</u> i) <u>Test supply voltages</u> ii) <u>Test freq. response and distortion</u> Spectrum analyzer on Bu42 Frequency input on 4031 a) <u>Frequency range 740-999.999 MHz</u> b) <u>Frequency range 500-739.999 MHz</u> c) <u>Frequency range 320-499.999 MHz</u>	Bu8 Bu9 Bu10	DC DC DC  740 MHz 870 MHz 999.9 MHz  500 MHz 640 MHz 739.9 MHz  320 MHz 410 MHz 499.9 MHz	Level Dist.	+5 ±0.1 V -15 ±0.1 V +15 ±0.1 V  +2 to -8 dBm < -40 dBc +2 to -8 dBm < -40 dBc +2 to -8 dBm < -40 dBc  +2 to -8 dBm < -40 dBc +2 to -8 dBm < -40 dBc +2 to -8 dBm < -40 dBc  +2 to -8 dBm < -40 dBc +2 to -8 dBm < -40 dBc +2 to -8 dBm < -40 dBc							
		Ref. No.	213 041 A									
		Type	STABLOCK 4031									

Necessary Equipment	Measuring Procedure	Measuring Point	Frequency	Adjustment	Set Value	Actual Value	Ref. No. 213 041 A				Sub Unit	Sheet
							Issue	Name	Date	Type		
	d) <u>Frequency range 250-319.999 MHz</u>		250 MHz 285 MHz 319.9 MHz	Level Dist.	+2 to -8 dBm < -40 dBc +2 to -8 dBm < -40 dBc +2 to -8 dBm < -40 dBc					UHF Synthesizer	2/11	
	e) <u>Frequency range 200-249.999 MHz</u>		200 MHz 225 MHz 249.9 MHz		+2 to -8 dBm < -40 dBc +2 to -8 dBm < -40 dBc +2 to -8 dBm < -40 dBc							
	f) <u>Frequency range 125-199.999 MHz</u>		125 MHz 162 MHz 199.9 MHz		+2 to -8 dBm < -40 dBc +2 to -8 dBm < -40 dBc +2 to -8 dBm < -40 dBc							



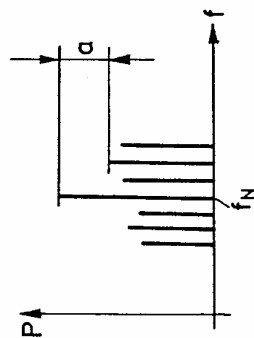

Necessary Equipment		Measuring Procedure				Measuring Point	Frequency	Adjustment	Set Value	Actual Value					
DVM, Spectrum analyzer, Voltage source	2. Oscillator 361 436 Measure voltage Tune oscillator with varactor voltage on Bu7 and check whether it oscillates in entire tuning range Terminate RF output on narrow side of PCB (Mp6) with 50 Ω	Mp3 Bu7 Mp7	DC DC -10 to +13 V		-11.7 ±1 V $f_{min} \leq 460$ MHz $f_{max} \geq 1040$ MHz										
DVM	Measure control voltage in tuning range	Mp5	DC		±4 V										
DVM	Measure voltage	Mp2	DC		-0.329 ±0.01 V										
Power meter (connecting cable < 20 cm!)	Measure power on RF output on wide side of PCB (Mp7); RF output on narrow side (Mp6) must be terminated with 50 Ω	Mp7	$f_{min}$ to $f_{max}$		0 ±2 dBm										
		Issue	Alteration No.	Date	Name	Issue	Alteration No.	Date	Name	Ref. No.	213 041 A	Sub Unit	UHF Synthesizer	Sheet	4/11
										Type	STABILLOCK 4031				

Necessary Equipment	Measuring Procedure	Measuring Point	Frequency	Adjustment	Set Value	Actual Value	Issue	Alteration No.	Date	Name	Alteration No.	Date	Name	Ref. No.	Sub Unit	Sheet	
							Alteration No.	Date	Name	Issue	Date	Name	Alteration No.	Date	Name	Type	UHF Synthesizer
4002 or similar, Frequency counter, RF probe, Spectrum analyzer	<p>3. <u>Programmable divider 361 439</u></p> <p>a) <u>Reference-frequency divider</u> Synchronize 4031 with 4002 Apply <math>f_{ref}</math> 500 MHz/+5 dBm on Bu41</p> <p>Measure with RF probe (20:1) and spectrum analyzer Set level reference on analyzer with CAL output and measure relatively</p> <p>Setting on 4031 500 MHz 600 MHz 700 MHz 800 MHz 900 MHz</p> 	Mp3 (D14/14)	5 MHz		5.000 MHz												
		Mp4 (D10/16)	$f_n = 250$ MHz $f_n = 300$ MHz $f_n = 350$ MHz $f_n = 400$ MHz $f_n = 450$ MHz		$> -7$ dBm $> -7$ dBm $> -7$ dBm $> -7$ dBm $> -7$ dBm												
		Mp4 (D10/16)	250-400 MHz 450 MHz		$a > 10$ dB $a \geq 5$ dB												

Necessary Equipment	Measuring Procedure	Measuring Point	Frequency	Adjustment	Set Value	Actual Value	Ref. No. 213 041 A			Sheet	
							Issue	Alteration No.	Date		Sub Unit
2 x 4002 or similar, Spectrum analyzer, Frequency counter, RF probe, DVM, Oscilloscope	<p>Measure with probe and frequency counter Setting on 4031:</p> <p>f = 500 MHz f = 600 MHz f = 700 MHz f = 800 MHz f = 900 MHz</p> <p>b) Oscillator-frequency divider Separate connection of oscillator o/p (361 436) on programmable divider i/p (361 439) and feed in f = 500-980 MHz/0 dBm with 4002 Measure frequency with probe Setting on 4031 and 4002</p> <p>f = 500 MHz f = 600 MHz f = 700 MHz f = 800 MHz f = 900 MHz</p> <p>Measure voltage</p>	<p>Mp5 (D10/8)</p> <p>Mp6 (D14/3)</p> <p>Mp9 (D12/14)</p>	<p>50 MHz 60 MHz 70 MHz 80 MHz 90 MHz</p> <p>5 MHz 5 MHz 5 MHz 5 MHz 5 MHz</p> <p>DC</p>		<p>50 MHz 60 MHz 70 MHz 80 MHz 90 MHz</p> <p>5.000 MHz 5.000 MHz 5.000 MHz 5.000 MHz 5.000 MHz</p> <p>H level (ECL) V &gt; 3.9 V</p>						
							Issue	Alteration No.	Date	Sub Unit	Type

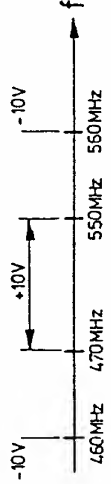
Schlumberger		Adjustment and Test Procedure							Sheet	
Necessary Equipment	Measuring Procedure	Measuring Point	Frequency	Adjustment	Set Value	Actual Value	Issue	Alteration No.	Date	Name
4002 or similar, DVM	<p>Measure frequency with probe Setting on 4031 and 4002:</p> <p>f = 900 MHz f = 920 MHz f = 940 MHz f = 960 MHz f = 980 MHz</p> <p>Measure voltage with oscilloscope at f = 920-980 MHz</p>  <p>For duty cycle, see p. 11</p> <p>c) Capture circuit Apply <math>f_{ref}</math> 500 MHz/+5 dBm on Bu41 Connection 361 436/361 439 still separated and oscillator frequency fed in with 4002 Setting on 4031 f = 500 MHz Alter oscillator frequency (4002) 0 dBm between 450 and 580 MHz</p> <p>Set capture range: Adjust R121 so that between f = 470 and 550 MHz and for f &gt; 560 MHz f &lt; 460 MHz</p> 	Mp6 (D14/3)  Mp9 (D12/14)   Mp1 Mp1 Mp1	5 MHz   DC DC DC	   R121 R121 R121	5 MHz   V <sub>H</sub> > 3.9 V V <sub>L</sub> < 3.4 V  V > +10 V V < -10 V V < -10 V		Ref. No. 213 041 A			
							Type			
							STABLOCK 4031			

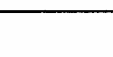
Necessary Equipment	Measuring Procedure	Measuring Point	Frequency	Adjustment	Set Value	Actual Value	Sheet							
							Issue	Alteration No.	Date	Sub Unit	UHF Synthesizer	8/11		
4002 or similar, Oscilloscope, DVM, Frequency counter, Analyzer	<u>Check integrator</u> Setting on 4031 f = 500 MHz Oscillator frequency (4002) 0 dBm f > 500 MHz (ie f too high) f < 500 MHz (ie f too low)	Mp2 (R105, C103)	DC DC		V > +10 V V > -10 V		Issue	Alteration No.	Date	Name	Ref. No.	213 041 A	Type	STABLOCK 4031
	<u>Mixture capture-range detection</u> Setting on 4031 f = 500 MHz Oscillator frequency (4002) 0 dBm f = 500 MHz f = 500 MHz ±600 kHz	Mp7 (A3/9)	DC		TTL Low 0-0.8 V TTL 									
	<u>Mixer locking range (check)</u> Bu41 f <sub>ref</sub> = 500 MHz/+5 dBm Resolder connection 361 436/361 439 Setting on 4031 f = 500 MHz Open jumper Br1 and apply DC (approx. -5 to -10 V) to R82 (Br1/1) Alter Vdc until f = 500.000 MHz Tune Vdc so that f = 500.000 MHz (remains synchronized) Close jumper Br1	A1/3	DC		ΔV approx. 300-400 mV									

Necessary Equipment	Measuring Procedure	Measuring Point	Frequency	Adjustment	Set Value	Actual Value	Ref. No. 213 041 A				Sub Unit	Sheet	
							Issue	Name	Date	Alteration No.			UHF Synthesizer
4002 or similar Frequency counter, Analyzer	<u>Control voltage (check)</u> Setting on 4031 $f = 500$ MHz On Bu41 $f_{ref} = 480$ MHz Setting on 4031 $f = 980$ MHz $f_{ref} = 520$ MHz  <u>Selfcheck</u> Setting on 4031 $f = 500$ MHz Br1 closed  Br1 open  <u>Synchronization check</u>  Setting on 4031 $f = 500, 600, 700, 800, 900, 980$ MHz Alter $f_{ref} = 500$ MHz on Bu41 so that output frequency $f_{out}$ is in range $f_{out} \geq f - 20$ MHz and $f_{out} \leq f + 40$ MHz UHF synthesizer is then synchronized over entire range	Bu19	DC		$V > -12.7$ V								
		Bu19	DC		$V < +12$ V								
		Mp8 (Bu10)	DC		TTL Low LED (G112) off TTL High LED (G112) on								
							Issue	Name	Date	Alteration No.	Type	STABLOCK 4031	

Level table for UHF synthesizer 361 439

	Bu1	Bu6	Bu5	Bu4	Bu3	Bu15	Bu16	Bu17	Bu18
500						L	L	L	L
20						L	L	L	H
40	L	H	H	L	L	L	L	H	H
60						H	L	H	H
80						H	H	H	H
600						L	L	L	L
20						L	L	L	H
40	H	L	H	L	H	L	L	H	H
60						H	L	H	H
80						H	H	H	H
700						L	L	L	L
20						L	L	L	H
40	H	L	H	H	L	L	L	H	H
60						L	H	H	H
80						H	H	H	H
800						L	L	L	L
20						L	L	L	H
40	L	L	H	H	H	L	H	L	H
60						H	H	L	H
80						H	H	H	H
900						L	L	L	L
20						L	L	L	H
40	L	L	L	L	L	L	H	L	H
60						L	H	H	H
80						H	H	H	H

Ref. No. 213 041 A  
 Type STABLOCK 4031

Sub Unit UHF Synthesizer

Date  
 Sheet 10/11



**Driving of dual-modulus divider (5/6) D11/pin 2, measured on Mp9 (see 3.b)**

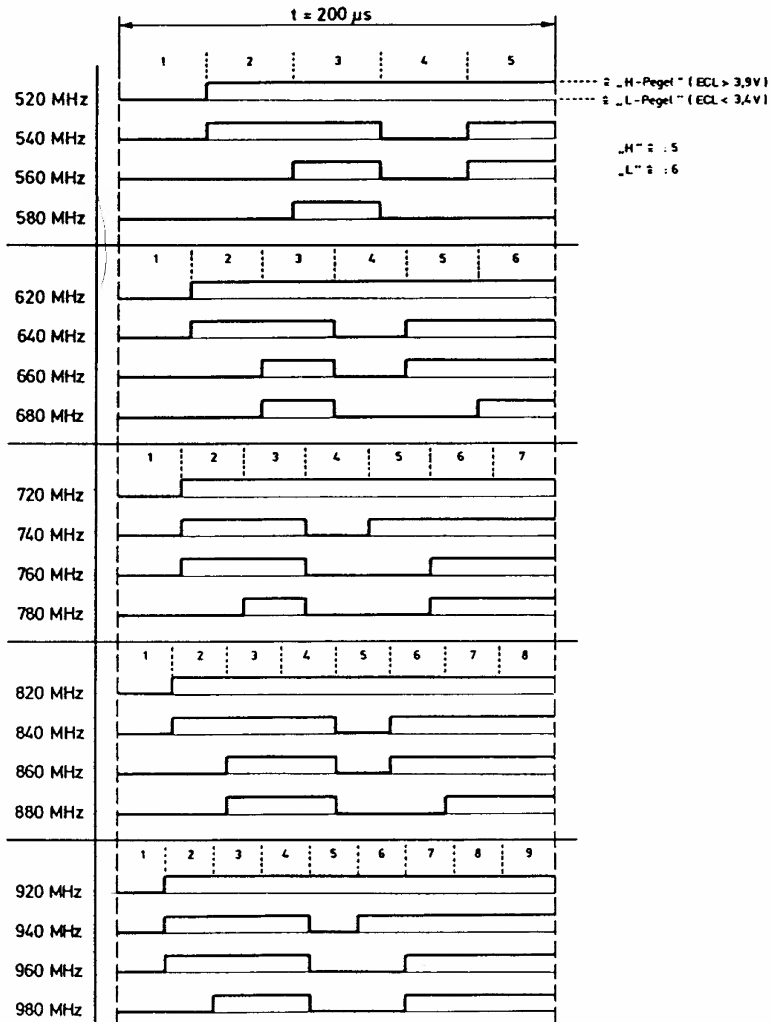

Ref. No. 213 041 A	Sub Unit UHF Synthesizer	Date
Type STABLOCK 4031		Sheet 11/11

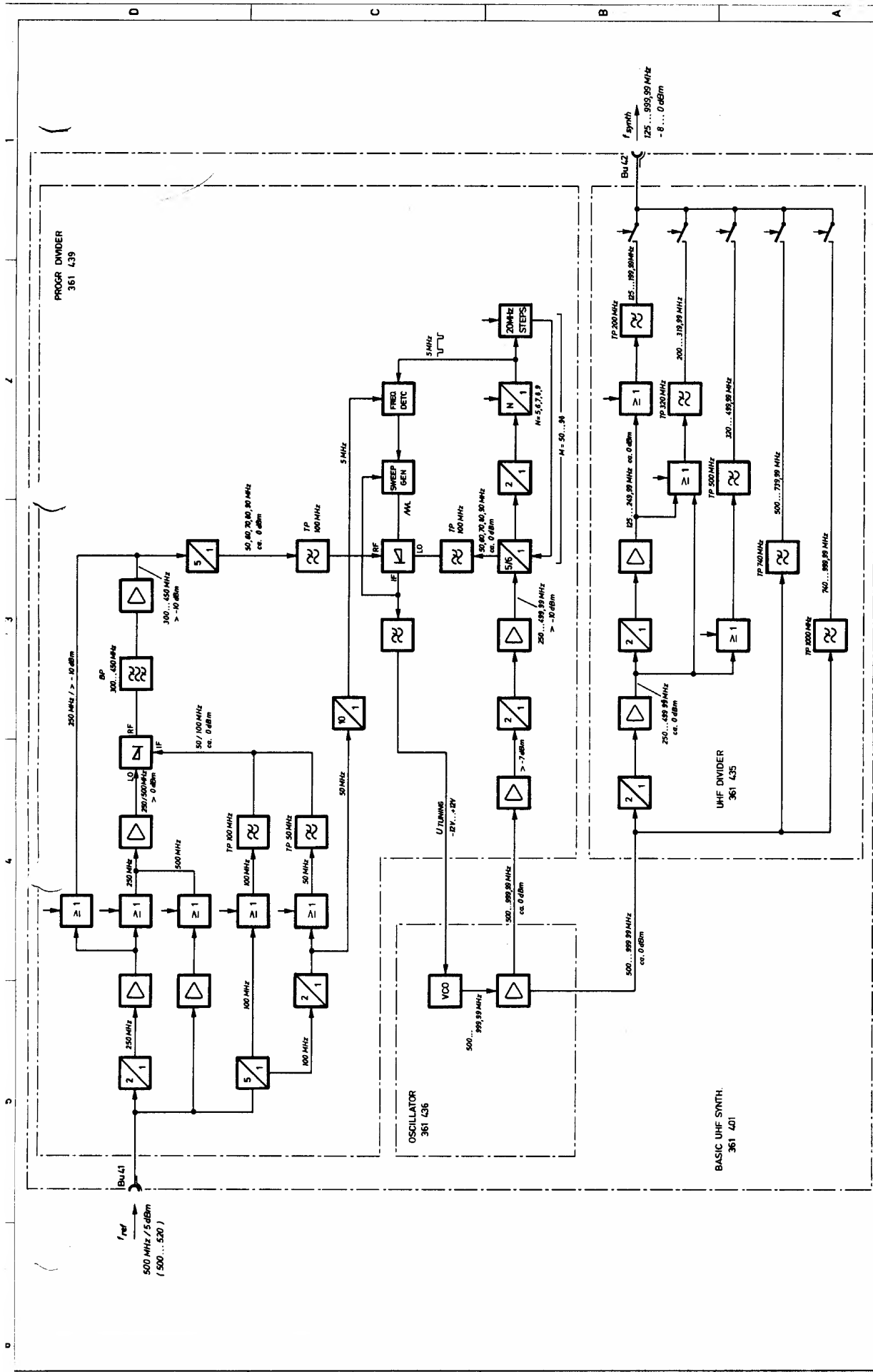

SW BLACK BR BROWN BK BLUE RD ROSE YE YELLOW GR GREEN		H BLUE H ROULET W WHITE T TRANSPARENT O OREEN		7025 MS 1.10.87 Datum	30.9.87 IC Datum	A-Hilfs Name 1987 DATE	NAME NAME DATE NAME	Schramberger Messtechnik GmbH Inpoststraße 67 a 8000 München 46	UHF-SYNTH BLOCK DIAGRAM	213 041 B Gerät : 4031
---	--	---	--	-----------------------------	------------------------	---------------------------------	------------------------------	---	----------------------------	---------------------------

REAR PANEL  
 $f_{ref}$   
500 MHz / 5 dBm  
(500...520)

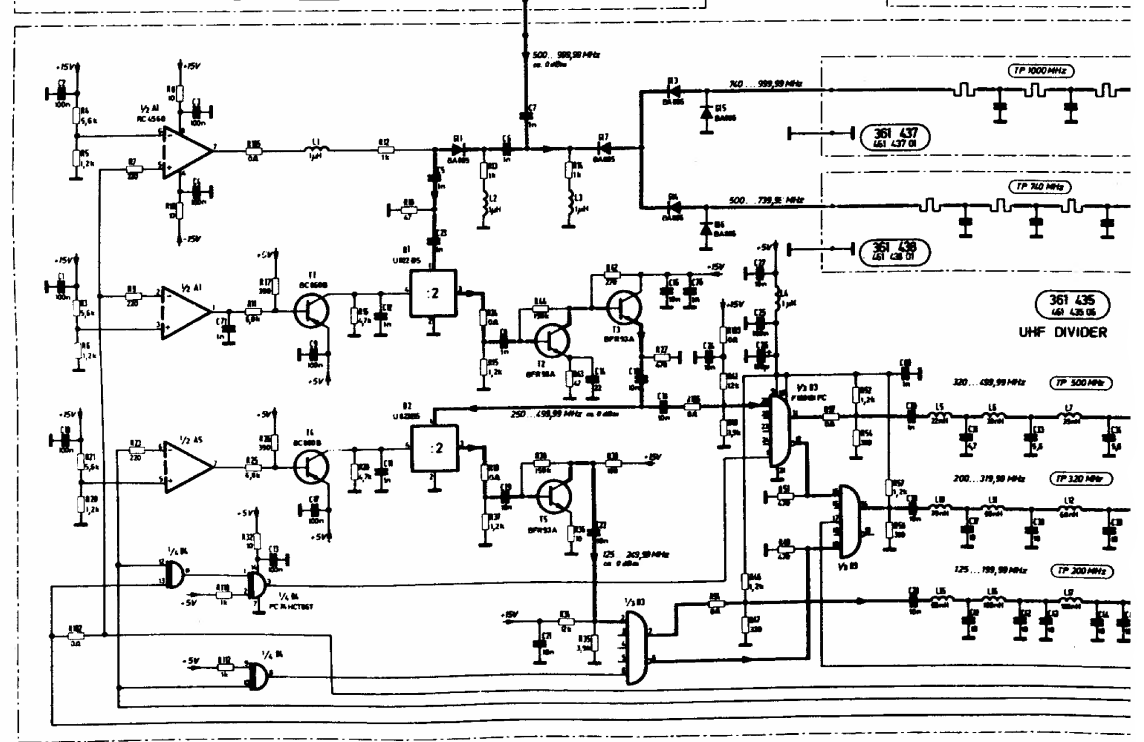
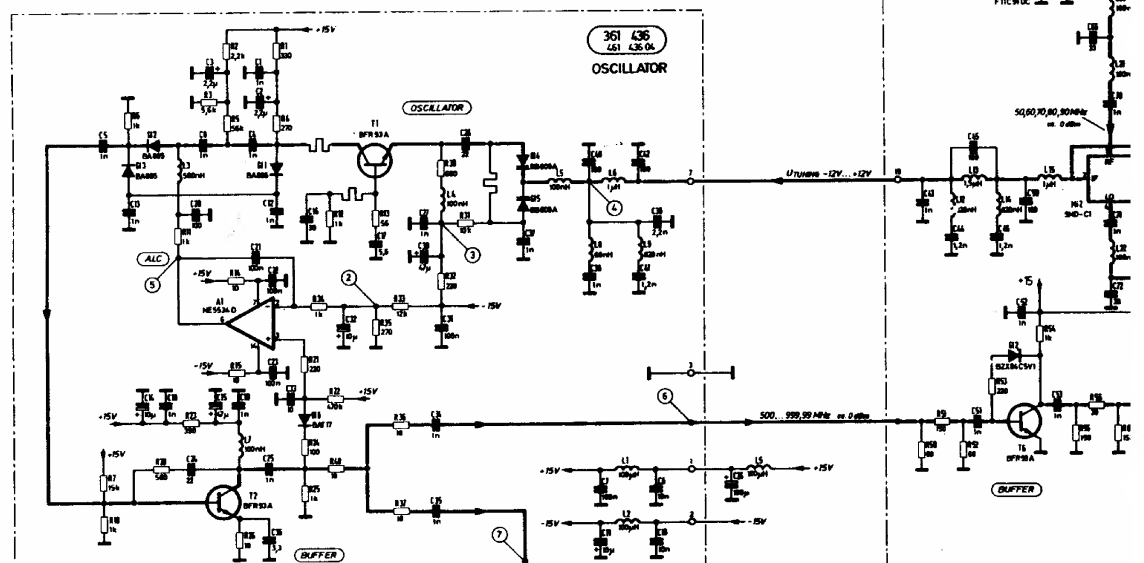
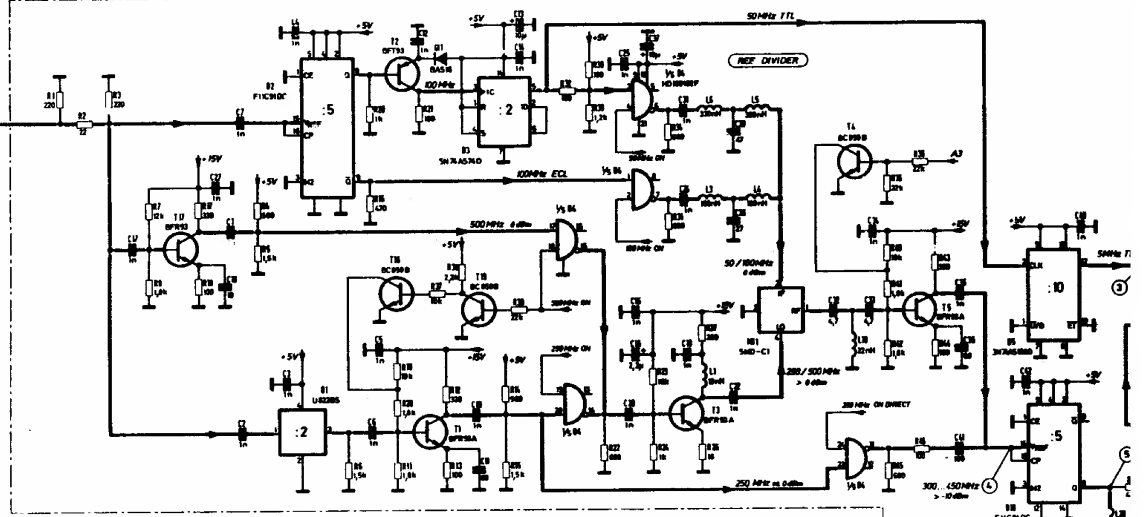



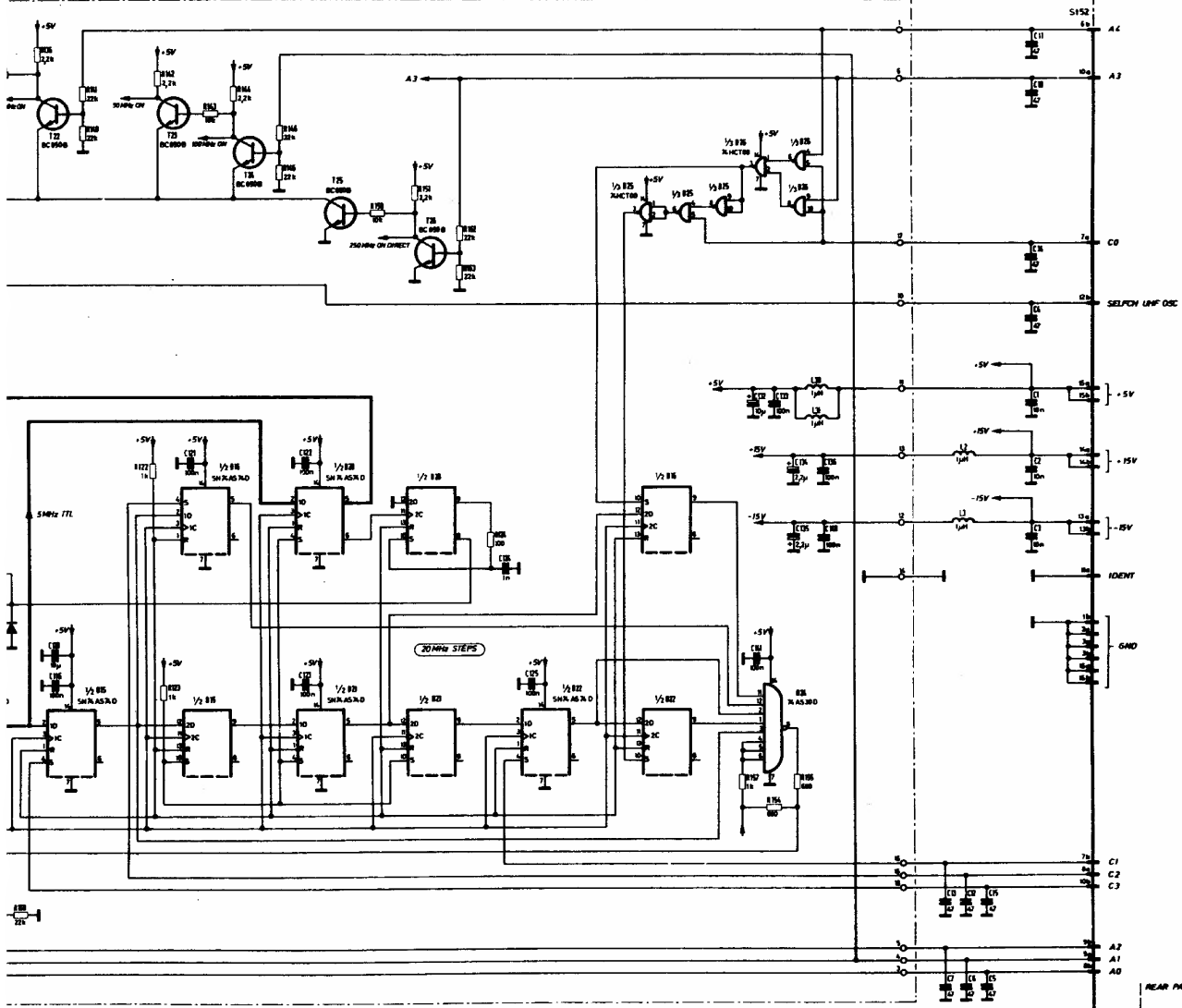

361 401  
401 401 01

BASIC UHF SYNTH

<ul style="list-style-type: none"> <li>BLACK</li> <li>BROWN</li> <li>RED</li> <li>ORANGE</li> <li>YELLOW</li> <li>GREEN</li> </ul>	<ul style="list-style-type: none"> <li>BLUE</li> <li>VIOLET</li> <li>GREY</li> <li>WHITE</li> <li>TRANSPARENT</li> </ul>	361 401 401 401 01	Schauberg & Müller Ing.-Büro Ing. A. Müller Ing. H. Müller	Schauberg & Müller Ing.-Büro Ing. A. Müller Ing. H. Müller	Schauberg & Müller Ing.-Büro Ing. A. Müller Ing. H. Müller	UHF SYNTH	213 041 S Typ: 4038
--	--	-----------------------	---	---	---	-----------	------------------------

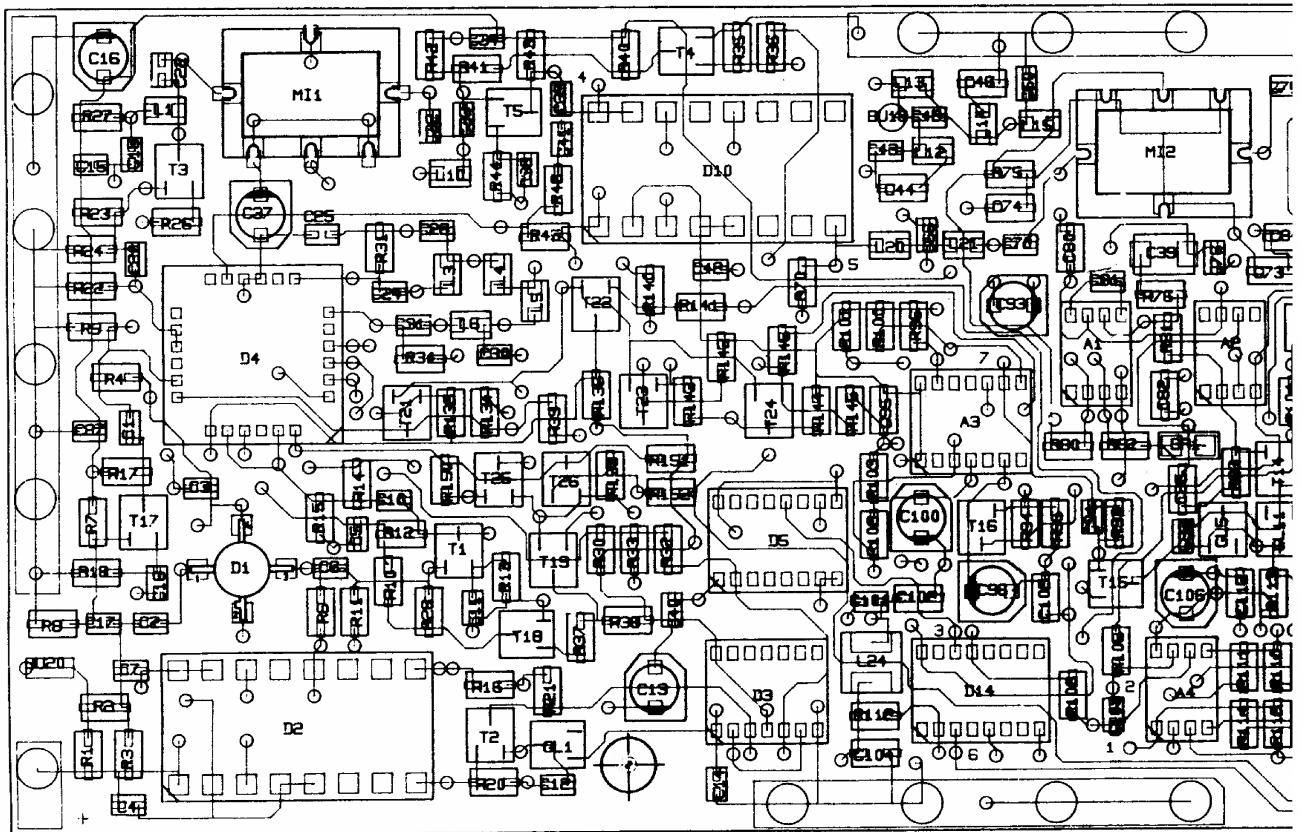

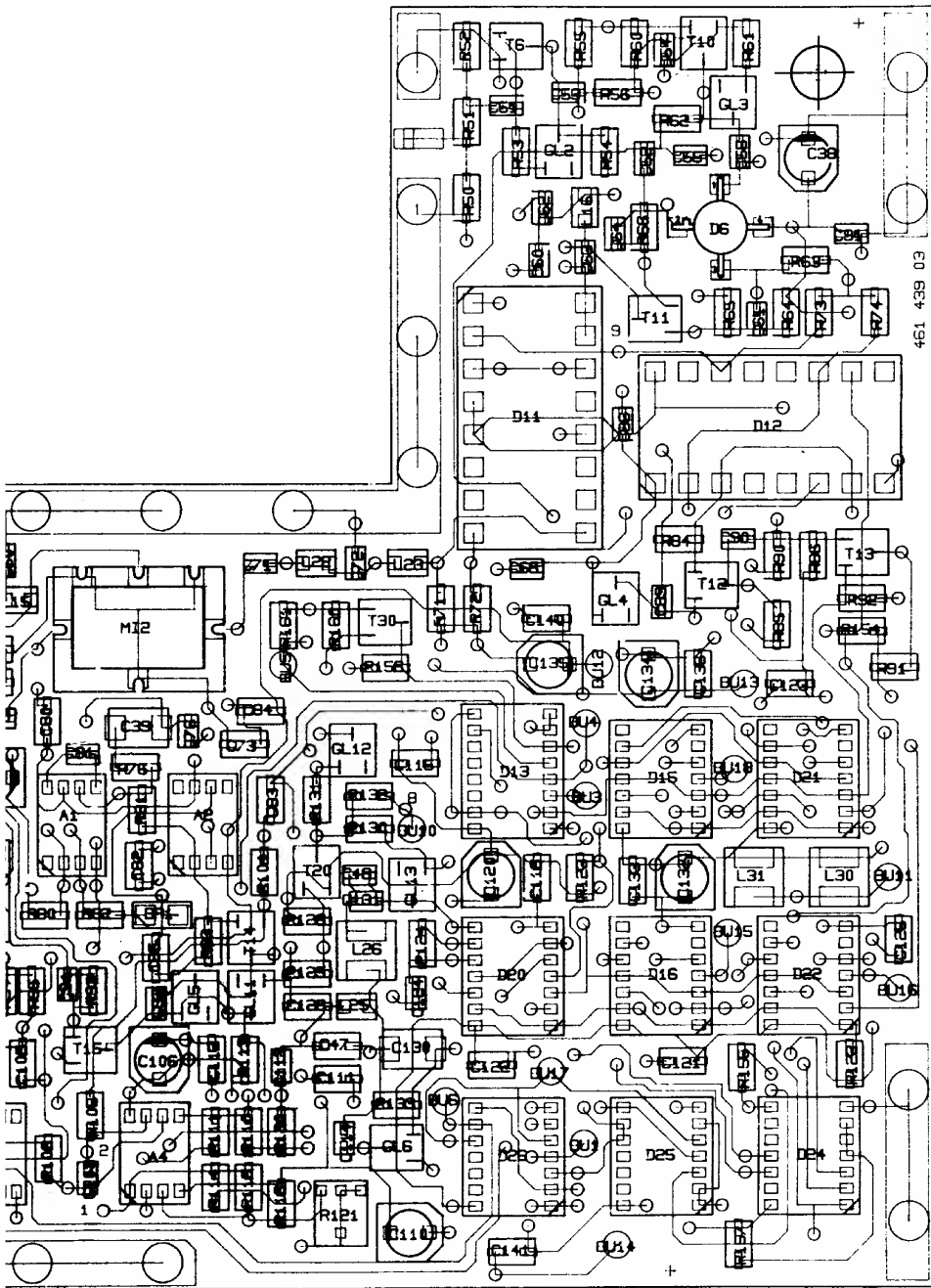

461 439 03

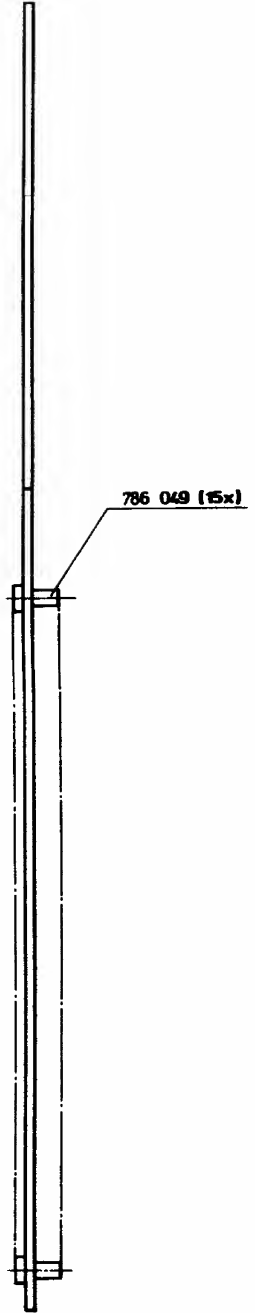

⊖ = Kontrollmaß

10									
9									
8									
7									
6									
5									
4									
3									
2									
1									

4:1	<b>Schlumberger o/s</b> <small>Produktion</small>
	<b>Bestückte Leiterplatte</b>
	Typ: <b>PROB. OMDER</b>
	<b>361 439</b>

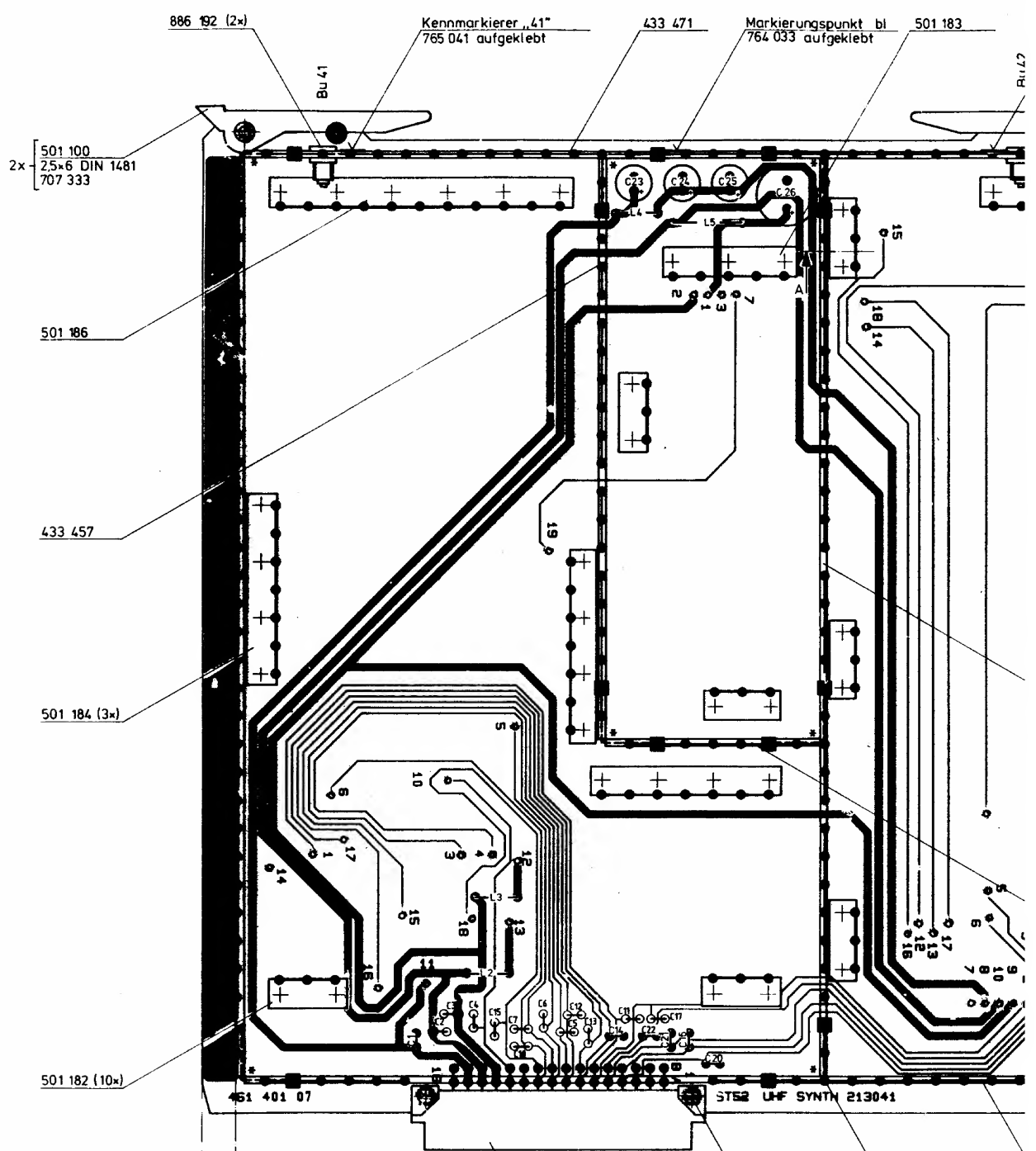

beide Randstreifen vor dem Lötén abgedeckt

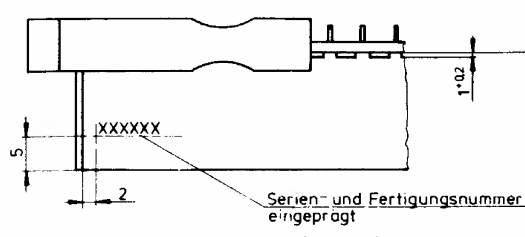





Ansicht  $\triangle$  Sollbe

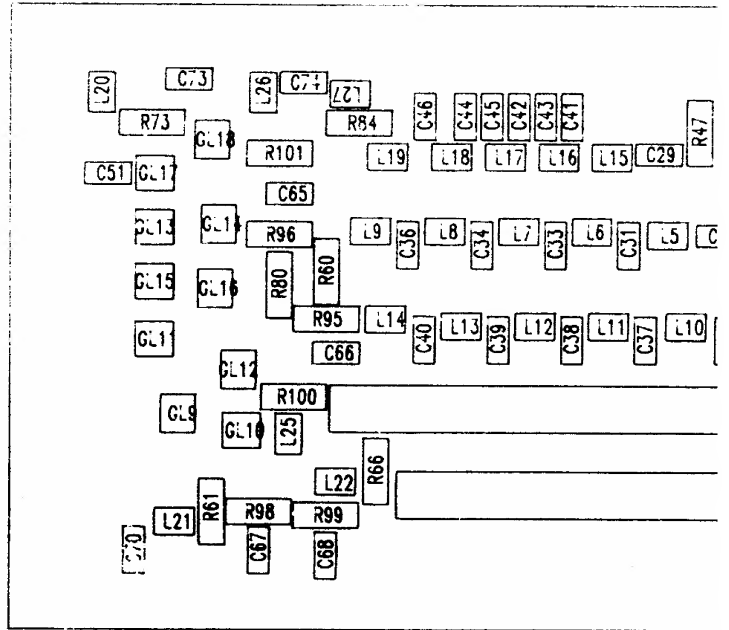

Ansicht mit Leiter

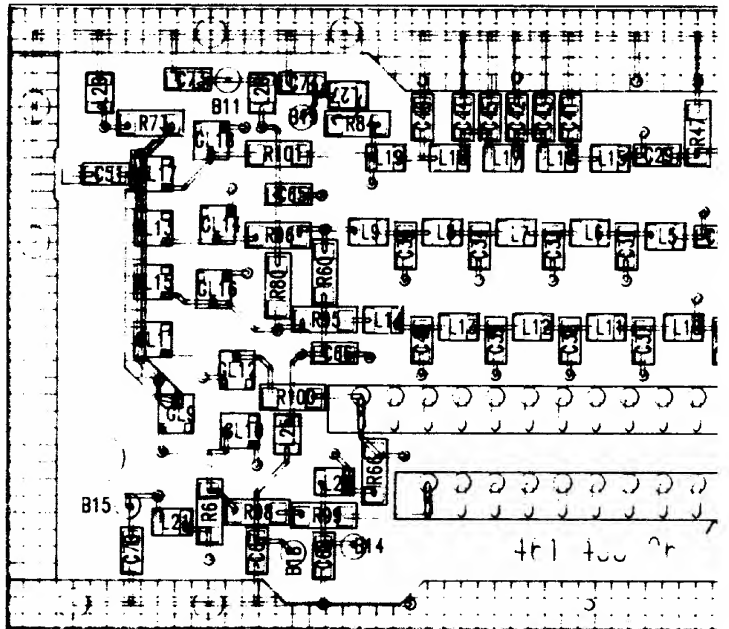



Reflow gelötet  
Hierzu Bauteilklebmaske 461 435 06

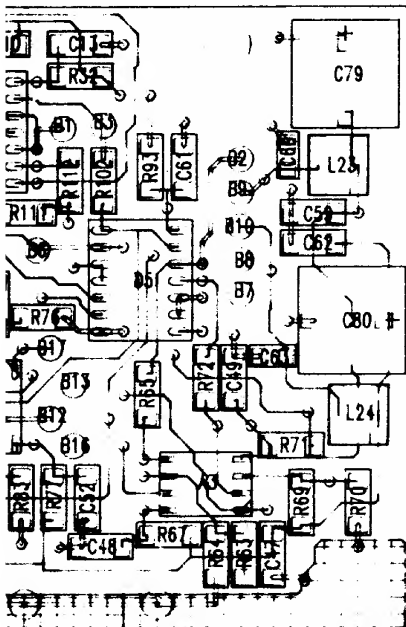
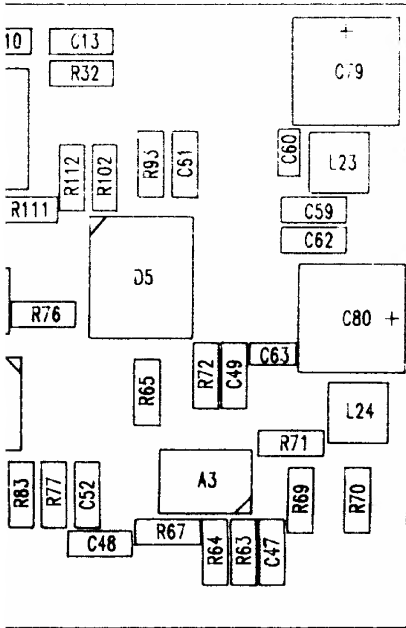

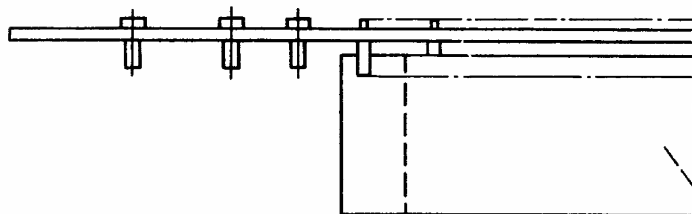
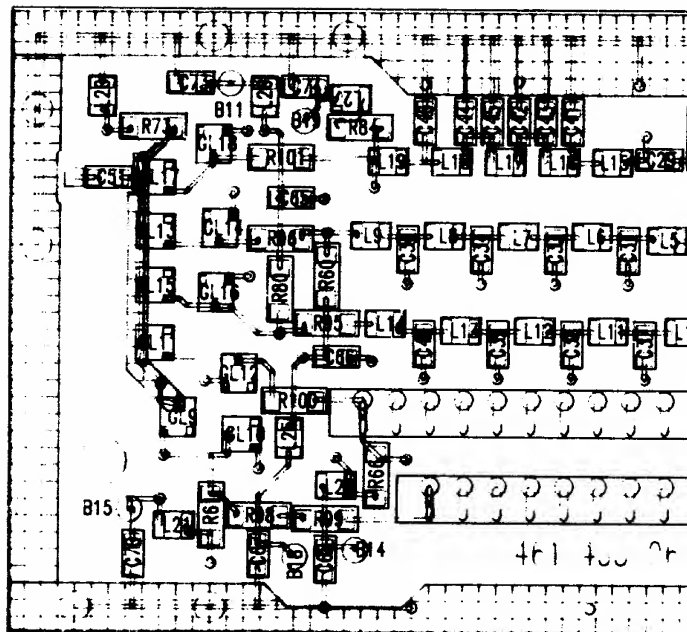

361 437  
auf Anschlag ge  
und komplett ver

Ansicht mit Leiterbahnen vollbestückt nur zur Orientierung

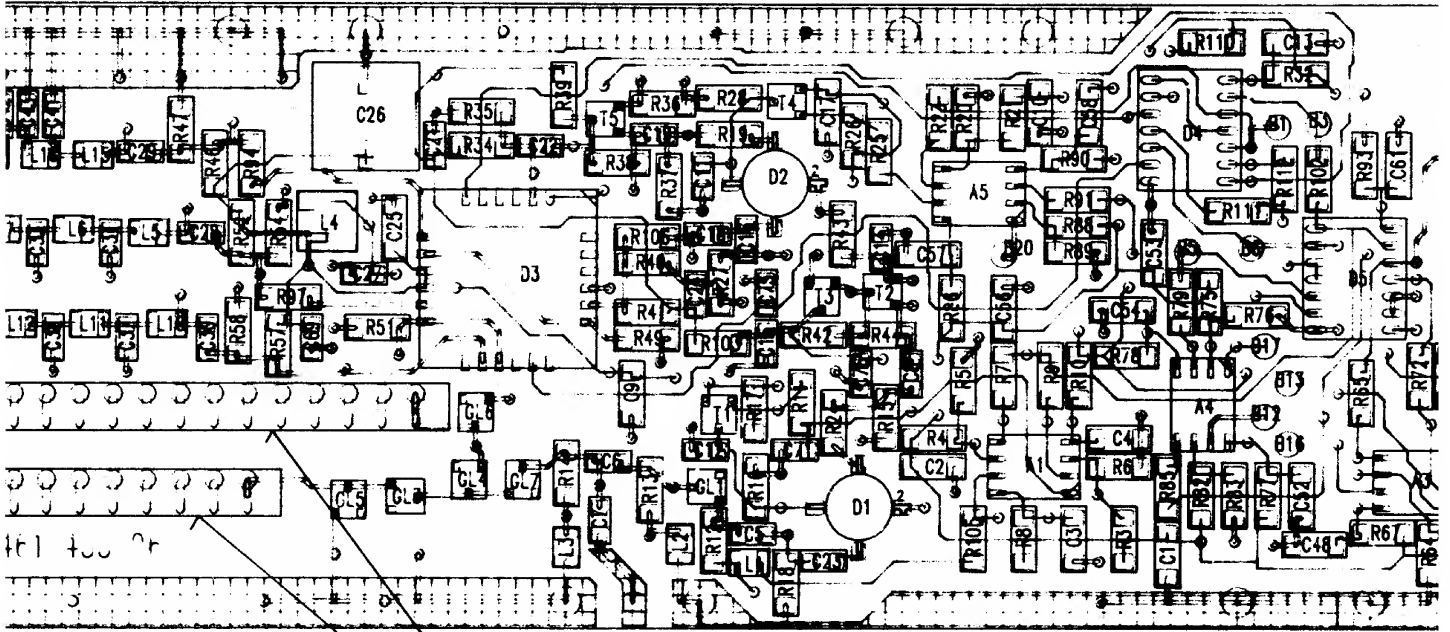

Bestückungsseite



361 437

361 437 auf Anschlag gesteckt  
361 437 komplett verlötet

361 438

361 438 auf Anschlag gesteckt  
361 438 und komplett verlötet

786 049 (20x)

10
09
08
07
06
05
04
03
02
01

Ausgabe

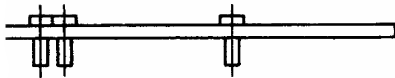
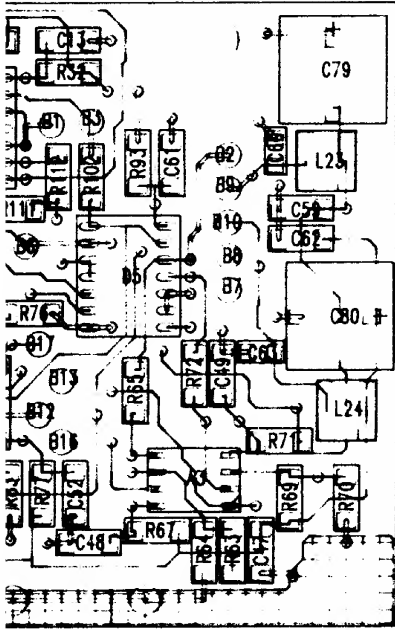

049 (20x)

10					Rohrteil	Freimad- toleranzen	Maßstab	Schlumberger Meßgeräte GmbH Ingolstädter Straße 67 a 8000 München 46
09								
08	8088,178	4,10,88	Kr.		Werkstoff		2:1	Bestückte Leiterplatte Typ : UHF DIVIDER
07								
06					Oberfläche	1988 Datum Name		361 435
05								
04					Ausgabe Andg. Mittig Datum Name	gez 4,10,88 Kr.	bearb 5.10.88	Gerät : 4031 / 213 041
03								
02								
01								

Diese Zeichnung ist unser Eigentum. Vervielfältigung, unbefugte Verwendung, Mitteilung an andere ist strikt verbotlich und schadenersatzpflichtig.

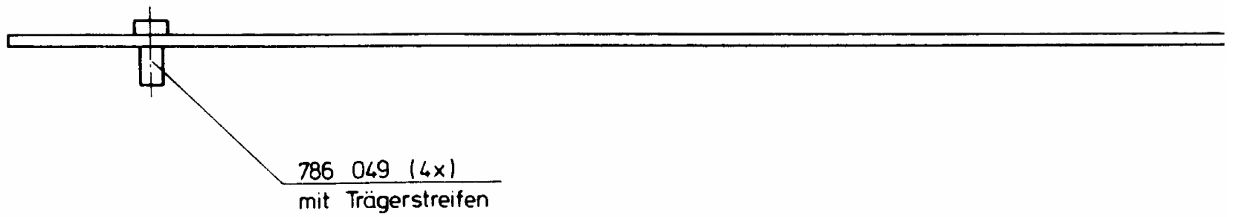
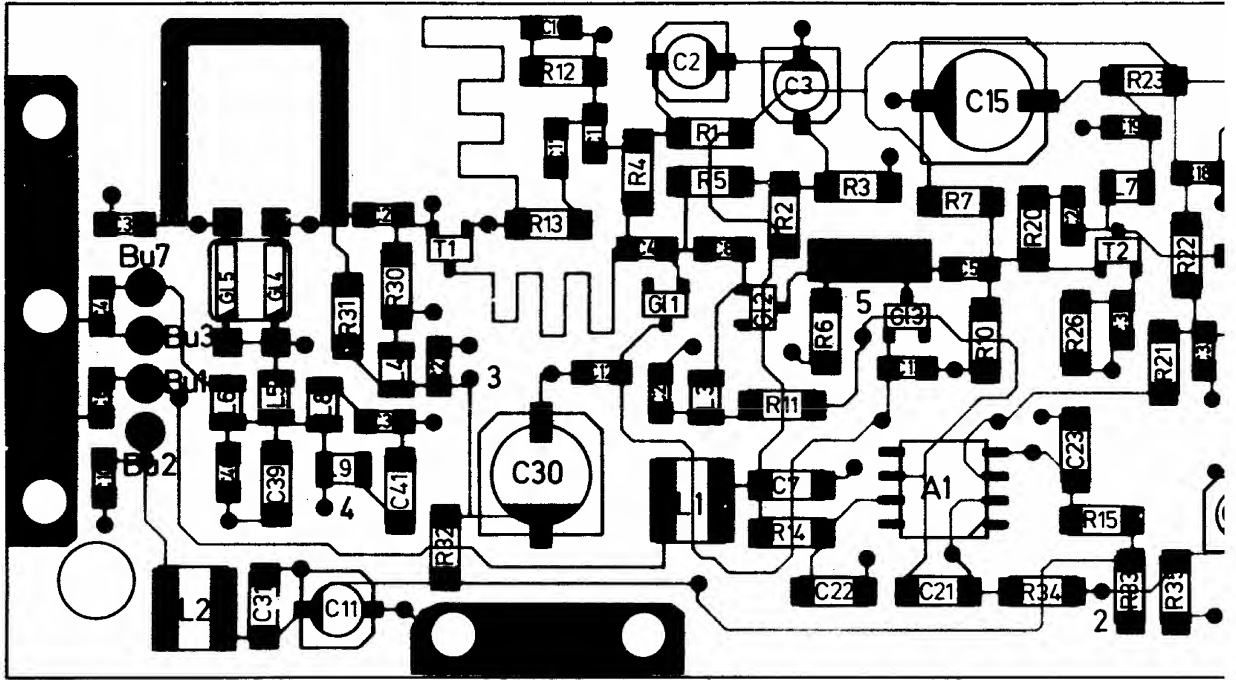





verwendet in: 361 437

Gerät: 4031

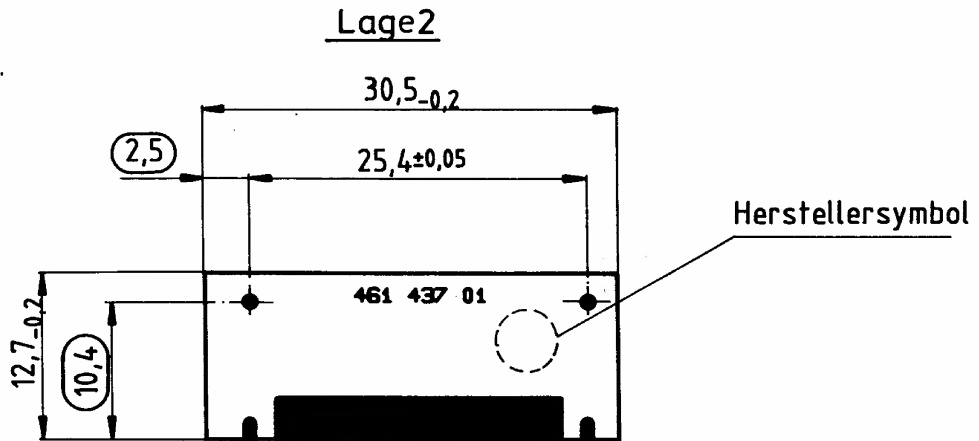

•  $\phi 2,5^{D10}$  (2x) nicht durchkontaktiert

**Achtung !**

Leiterbahnbreite im Originalfilm  $0,51 \pm 0,01$   
 Fertigungsvorgabe je nach Verfahren durch den Hersteller im Fertigungsfilm erbracht.

Lage 1

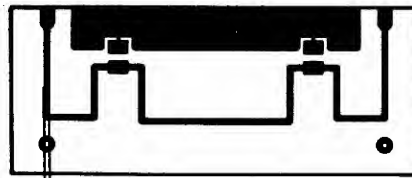

Leiterbahnbreite  
 Kontrollmaß  $0,53_{-0,05}$   
 Gesamter Leiterzug

= Kontrollmaß

FERTIGUNGSHILFSMITTEL		
LEITERBILDFILM	LAGE 1	X
	LAGE 2	X
LOETSTOPMASKE	ZWEISEITIG	
	LAGE 1	
	LAGE 2	
BOHRFILM		X
BOHRLOCHSTR.		
NUTZEN ZEICHNUNG		X
POS. DRUCK	LAGE 1	
	LAGE 2	

10				Rohteil	745 042	Freimaßtoleranzen	$\pm 0,2$	Maßstab	2:1	Schlumberger Meßgeräte GmbH Ingolstädter Straße 67 a 8000 München 46
09				Werkstoff						
08										Leiterplatte Typ: FILTER
07										
06	8088.12	26.9.88	Kr.							461 437
05	7088.40	12.5.87	Ac.							
04	7088.74	11.6.87	Mo							Ersatz für
03	7088.29	11.2.87	St.							
02				Oberfläche	chem. verzinkt ca. 1 $\mu$	1987	Datum	Name		
01						gez	11.2.	Staffler		
Ausgabe	Änd-Mittig	Datum	Name			bearb				

Diese Zeichnung ist unser Eigentum. Vervielfältigung unbefugte Verwertung, Mitteilung an andere ist strafbar und schadenersatzpflichtig.

verwendet in: 361 438

Gerät: 4031

Lage 2

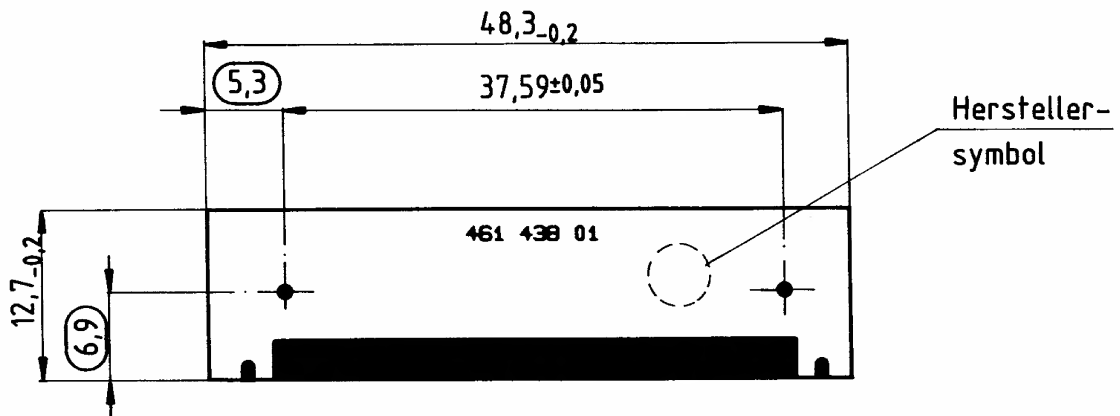

•  $\phi 2,5^{D10}$  (2x) nicht durchkontaktiert

Achtung !

Leiterbahnbreite im Originalfilm  $0,51 \pm 0,01$   
 Fertigungsvorgabe je nach Verfahren durch den Hersteller im Fertigungsfilm erbracht.

Lage 1

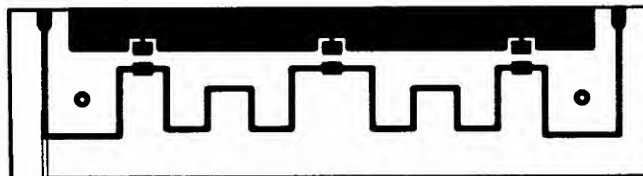

Leiterbahnbreite  
 Kontrollmaß  $0,53_{-0,05}$   
 Gesamter Leiterzug

= Kontrollmaß

FERTIGUNGSHILFSMITTEL		X
LEITERBILDFILM	LAGE 1	X
	LAGE 2	X
LOETSTOPMASKE	ZWEISEITIG	
	LAGE 1	
	LAGE 2	
BOHRFILM		X
BOHRLOCHSTR.		
NUTZEN ZEICHNUNG		X
POS. DRUCK	LAGE 1	
	LAGE 2	

10				Rohteil	745 042	Freimaßtoleranzen	$\pm 0,2$	Maßstab	2:1	Schlumberger Meßgeräte GmbH Ingoistädter Straße 67 a 8000 München 46
09				Werkstoff						
08										Leiterplatte Typ: FILTER
07										
06	8088.172	26.9.88	Kr.							461 438
05	7088.140	19.5.88	Ar.							
04	7088.74	11.6.87	Mo.							Ersatz für
03	7088.20	11.2.87	Kr.							
02				Oberfläche	chem. verzinkt ca. 1 $\mu$	1987	Datum	Name		
01						gez	11.2.	Staffler		
Ausgabe	Ändg-Mittig	Datum	Name			bearb				

1	2	3	4	5	6	7	8
Pos. REF. NO.	Wert VALUE	Bezeichnung Schlumberger PART. NO.	Hersteller MANUFACT	Pos. REF. NO.	Wert VALUE	Bezeichnung Schlumberger PART. NO.	Hersteller MANUFACT
1	Bestückte Leiterplatte PRINTED CIRCUIT BOARD	361 401	SCHL				
	hierzu SEE	361 401 Sa					
1	Bestückte Leiterplatte PRINTED CIRCUIT BOARD	361 435	SCHL				
	hierzu SEE	361 435 Sa					
1	Bestückte Leiterplatte PRINTED CIRCUIT BOARD	361 436	SCHL				
	hierzu SEE	361 436 Sa					
1	Bestückte Leiterplatte PRINTED CIRCUIT BOARD	361 439	SCHL				
	hierzu SEE	361 439 Sa					

07				Schlumberger Meßgeräte GmbH Ingolstädter Straße 67 a 8000 München 46			Schaltteilliste EL. PARTS LIST		Liste besteht LIST CONSISTS aus OF 1 Blatt SHEETS
06									
05							Bezeichnung Schlumberger PART. NO. 213 041 Sa		Blatt Nr. SHEET NO. 1
04							Hierzu Schaltplan SEE CIRCUIT DIAGRAM 213 041		
03							Gerät: 4031 / 201 231		
02				1988	Tag DATE	Name NAME			
01				1988	29.3.88	Reinhold, T.			
--	8088.53	29.3.88	Rein.	geschr.					
Aus- gabe ISSUE	Änd.-Mittg. Nr. MODIFIC. NO.	Tag DATE	Name NAME	bearb. gepr.		<i>Re</i>			

Diese Zeichnung ist unser Eigentum. Vervielfältigung, unbefugte Verwertung, Mitteilung an andere ist strafbar und schadenersatzpflichtig.

1	2		3		4	5		6		7		8
Pos. REF. NO.	Wert VALUE		Bezeichnung Schlumberger PART. NO.		Hersteller MANUFACT	Pos. REF. NO.	Wert VALUE		Bezeichnung Schlumberger PART. NO.		Hersteller MANUFACT	
A 1	RC 4560		834 210		RAY	C 18	10 nF $\pm$ 10 % 50 V-		813 332		VAL	
						C 19	10 nF $\pm$ 10 % 50 V-		813 332		VAL	
A 3	RC 4560		834 210		RAY	C 20						
A 4	RC 4560		834 210		RAY	C 21	10 nF $\pm$ 10 % 50 V-		813 332		VAL	
A 5	RC 4560		834 210		RAY	C 22	10 nF $\pm$ 10 % 50 V-		813 332		VAL	
						C 23	1 nF $\pm$ 10 % 50 V-		813 320		VAL	
						C 24	10 nF $\pm$ 10 % 50 V-		813 332		VAL	
						C 25	100 nF $\pm$ 10 % 50 V-		813 375		VAL	
						C 26	100 $\mu$ F $\pm$ 20 % 6,3 V-		814 394		RÖD	
						C 27	10 nF $\pm$ 10 % 50 V-		813 332		VAL	
C 1	100 nF $\pm$ 10 % 50 V-		813 375		VAL	C 28	10 nF $\pm$ 10 % 50 V-		813 332		VAL	
C 2	100 nF $\pm$ 10 % 50 V-		813 375		VAL	C 29	10 nF $\pm$ 10 % 50 V-		813 332		VAL	
C 3	100 nF $\pm$ 10 % 50 V-		813 375		VAL	C 30	10 nF $\pm$ 10 % 50 V-		813 332		VAL	
C 4	100 nF $\pm$ 10 % 50 V-		813 375		VAL	C 31	4,7 pF $\pm$ 0,25 pF 50 V-		813 219		VAL	
C 5	1 nF $\pm$ 10 % 50 V-		813 320		VAL							
C 6	1 nF $\pm$ 10 % 50 V-		813 320		VAL	C 33	5,6 pF $\pm$ 0,25 pF 50 V-		813 220		VAL	
C 7	1 nF $\pm$ 10 % 50 V-		813 320		VAL	C 34	5,6 pF $\pm$ 0,25 pF 50 V-		813 220		VAL	
C 8	1 nF $\pm$ 10 % 50 V-		813 320		VAL							
C 9	100 nF $\pm$ 10 % 50 V-		813 375		VAL	C 36	4,7 pF $\pm$ 0,25 pF 50 V-		813 219		VAL	
C 10	100 nF $\pm$ 10 % 50 V-		813 375		VAL	C 37	10 pF $\pm$ 5 % 50 V-		813 223		VAL	
C 11	1 nF $\pm$ 10 % 50 V-		813 320		VAL	C 38	10 pF $\pm$ 5 % 50 V-		813 223		VAL	
C 12	1 nF $\pm$ 10 % 50 V-		813 320		VAL	C 39	10 pF $\pm$ 5 % 50 V-		813 223		VAL	
C 13	100 nF $\pm$ 10 % 50 V-		813 375		VAL	C 40	10 pF $\pm$ 5 % 50 V-		813 223		VAL	
C 14	27 pF $\pm$ 5 % 50 V-		813 228		VAL	C 41	18 pF $\pm$ 5 % 50 V-		813 226		VAL	
C 15	10 nF $\pm$ 10 % 50 V-		813 332		VAL	C 42	10 pF $\pm$ 5 % 50 V-		813 223		VAL	
C 16	10 nF $\pm$ 10 % 50 V-		813 332		VAL	C 43	10 pF $\pm$ 5 % 50 V-		813 223		VAL	
C 17	100 nF $\pm$ 10 % 50 V-		813 375		VAL	C 44	10 pF $\pm$ 5 % 50 V-		813 223		VAL	
07					Schlumberger Meßgeräte GmbH Ingolstädter Straße 67a 8000 München 46		Schaltteilliste EL. PARTS LIST				Liste besteht LIST CONSISTS	
06											Benennung DESCRIPTION	
05							Bezeichnung Schlumberger PART. NO.		361 435 Sa		Blatt SHEETS	
04							Hierzu Schaltplan SEE CIRCUIT DIAGRAM		213 041 S		Blatt Nr. SHEET NO	
03	7088.142	10.9.87	Di		geschr	3.12.86	Dietrich			1		
02	7088.74	11.6.87	Mo		bearb							
01	6088.65	4.12.86	Di	1986	gepr							
---	6088.63	3.12.86	Di		gepr							
Aus- gabe ISSUE	Änd- Nr. MODIFIC. NO.	Tag DATE	Name NAME					Gerät: 4031				

Diese Zeichnung ist unser Eigentum. Vervielfältigung, unbefugte Verwertung, Mitteilung an andere ist strafbar und schadenersatzpflichtig.

1	2			3		4		5		6		7		8	
Pos. REF. NO.	Wert VALUE			Bezeichnung Schlumberger PART. NO.		Hersteller MANUFACT		Pos. REF. NO.	Wert VALUE			Bezeichnung Schlumberger PART. NO.		Hersteller MANUFACT	
C 45	10 pF $\pm 5\%$ 50 V-			813 223		VAL									
C 46	18 pF $\pm 5\%$ 50 V-			813 226		VAL		C 73	1 nF $\pm 10\%$ 50 V-			813 320		VAL	
C 47	100 nF $\pm 10\%$ 50 V-			813 375		VAL		C 74	1 nF $\pm 10\%$ 50 V-			813 320		VAL	
C 48	100 nF $\pm 10\%$ 50 V-			813 375		VAL		C 75	1 nF $\pm 10\%$ 50 V-			813 320		VAL	
C 49	100 nF $\pm 10\%$ 50 V-			813 375		VAL		C 76	1 nF $\pm 10\%$ 50 V-			813 320		VAL	
C 51	10 nF $\pm 10\%$ 50 V-			813 332		VAL		C 79	47 $\mu$ F $\pm 20\%$ 16 V-			814 386		RÖD	
C 52	100 nF $\pm 10\%$ 50 V-			813 375		VAL		C 80	47 $\mu$ F $\pm 20\%$ 16 V-			814 386		RÖD	
C 53	100 nF $\pm 10\%$ 50 V-			813 375		VAL									
C 54	100 nF $\pm 10\%$ 50 V-			813 375		VAL		D 1	U 822 BS			834 428		TELE	
								D 2	U 822 BS			834 428		TELE	
C 56	100 nF $\pm 10\%$ 50 V-			813 375		VAL		D 3	F 100 101 FC			834 422		FAIR	
C 57	100 nF $\pm 10\%$ 50 V-			813 375		VAL		D 4	PC 74 HCT 86 T			834 434		VAL	
C 58	100 nF $\pm 10\%$ 50 V-			813 375		VAL		D 5	PC 74 HCT 86 T			834 434		VAL	
C 59	100 nF $\pm 10\%$ 50 V-			813 375		VAL									
C 60	10 nF $\pm 10\%$ 50 V-			813 332		VAL									
C 61	100 nF $\pm 10\%$ 50 V-			813 375		VAL									
C 62	100 nF $\pm 10\%$ 50 V-			813 375		VAL									
C 63	10 nF $\pm 10\%$ 50 V-			813 332		VAL		G1 1	BA 885			830 533		SIE	
C 65	1 nF $\pm 10\%$ 50 V-			813 320		VAL		G1 3	BA 885			830 533		SIE	
C 66	1 nF $\pm 10\%$ 50 V-			813 320		VAL		G1 4	BA 885			830 533		SIE	
C 67	1 nF $\pm 10\%$ 50 V-			813 320		VAL		G1 5	BA 885			830 533		SIE	
C 68	1 nF $\pm 10\%$ 50 V-			813 320		VAL		G1 6	BA 885			830 533		SIE	
C 69	1 nF $\pm 10\%$ 50 V-			813 320		VAL		G1 7	BA 885			830 533		SIE	
C 70	1 nF $\pm 10\%$ 50 V-			813 320		VAL									
C 71	1 nF $\pm 10\%$ 50 V-			813 320		VAL		G1 9	BA 885			830 533		SIE	
07				Schlumberger Meßgeräte GmbH Ingolstädter Straße 67a 8000 München 46				Schaltteilliste EL. PARTS LIST Benennung DESCRIPTION Bestückte Leiterplatte Typ: UHF-Divider				Liste besteht LIST CONSISTS			
06												aus OF 6			
05								Blatt SHEETS							
04															
03															
02															
01	7088.74	11.6.87	Mo.	1986	Tag DATE	Name NAME	Bezeichnung Schlumberger PART NO		361 435 Sa		Blatt Nr. SHEET NO.				
	6088.63	3.12.86	Di	geschr.	3.12.86	Dietrich	Hierzu Schaltplan SEE CIRCUIT DIAGRAM		213 041 S		2				
Aus- gabe ISSUE	Änd.-Mittig Nr. MODIFIC. NO.	Tag DATE	Name NAME	gepr.			Gerät:		4031						

Diese Zeichnung ist unser Eigentum. Vervielfältigung, unbefugte Verwertung, Mitteilung an andere ist strafbar und schadenersatzpflichtig.

mm

Erich Feucht München 10 6397 80

1	2			3		4	5	6		7		8		
Pos. REF. NO.	Wert VALUE			Bezeichnung Schlumberger PART. NO.		Hersteller MANUFACT	Pos. REF. NO.	Wert VALUE		Bezeichnung Schlumberger PART. NO.		Hersteller MANUFACT		
G1 10	BA 885			830 533		SIE	L 14	39 nH $\pm 10\%$		821 210		STET		
G1 11	BA 885			830 533		SIE	L 15	68 nH $\pm 5\%$		821 213		STET		
G1 12	BA 885			830 533		SIE	L 16	100 nH $\pm 5\%$		821 215		STET		
G1 13	BA 885			830 533		SIE	L 17	100 nH $\pm 5\%$		821 215		STET		
G1 14	BA 885			830 533		SIE	L 18	100 nH $\pm 5\%$		821 215		STET		
G1 15	BA 885			830 533		SIE	L 19	68 nH $\pm 5\%$		821 213		STET		
G1 16	BA 885			830 533		SIE	L 20	1 $\mu$ H $\pm 5\%$		821 227		STET		
G1 17	BA 885			830 533		SIE	L 21	1 $\mu$ H $\pm 5\%$		821 227		STET		
G1 18	BA 885			830 533		SIE	L 22	1 $\mu$ H $\pm 5\%$		821 227		STET		
							L 23	1 $\mu$ H $\pm 20\%$		821 310		SIE		
							L 24	1 $\mu$ H $\pm 20\%$		821 310		SIE		
							L 25	1 $\mu$ H $\pm 5\%$		821 227		STET		
							L 26	1 $\mu$ H $\pm 5\%$		821 227		STET		
							L 27	1 $\mu$ H $\pm 5\%$		821 227		STET		
L 1	1 $\mu$ H $\pm 5\%$			821 227		STET								
L 2	1 $\mu$ H $\pm 5\%$			821 227		STET								
L 3	1 $\mu$ H $\pm 5\%$			821 227		STET								
L 4	1 $\mu$ H $\pm 20\%$			821 310		SIE								
L 5	22 nH $\pm 20\%$			821 208		STET								
L 6	39 nH $\pm 10\%$			821 210		STET								
L 7	39 nH $\pm 10\%$			821 210		STET								
L 8	39 nH $\pm 10\%$			821 210		STET								
L 9	22 nH $\pm 20\%$			821 208		STET								
L 10	39 nH $\pm 10\%$			821 210		STET	R 3	5,6 k $\Omega$ $\pm 2\%$		804 746		VAL		
L 11	68 nH $\pm 5\%$			821 213		STET	R 4	5,6 k $\Omega$ $\pm 2\%$		804 746		VAL		
L 12	68 nH $\pm 5\%$			821 213		STET	R 5	1,2 k $\Omega$ $\pm 2\%$		804 738		VAL		
L 13	68 nH $\pm 5\%$			821 213		STET	R 6	1,2 k $\Omega$ $\pm 2\%$		804 738		VAL		
07				Schlumberger Meßgeräte GmbH Ingolstädter Straße 67 a 8000 München 46			Schaltteilliste EL. PARTS LIST Benennung DESCRIPTION Bestückte Leiterplatte Typ: UHF-Di vider					Liste besteht LIST CONSISTS aus OF 6 Blatt SHEETS		
06														
05														
04														
03														
02														
01							1986	Tag DATE	Name NAME	Bezeichnung Schlumberger PART. NO		361 435 Sa		Blatt Nr. SHEET NO  3
	6088-63	3.12.86	Di	gechr.	3.12.86	Dietrich	Hierzu Schaltplan SEE CIRCUIT DIAGRAM		213 041 S					
Aus- gabe ISSUE	Änd.-Mittlg. Nr. MODIFIC. NO.	Tag DATE	Name NAME	bearb.		<i>LD</i>	Gerät: 4031							
				gepr.										

Diese Zeichnung ist unser Eigentum. Vervielfältigung, unbefugte Verwertung, Mitteilung an andere ist strafbar und schadenersatzpflichtig.

1	2	3	4	5	6	7	8
Pos. REF. NO.	Wert VALUE	Bezeichnung Schlumberger PART. NO.	Hersteller MANUFACT	Pos. REF. NO.	Wert VALUE	Bezeichnung Schlumberger PART. NO.	Hersteller MANUFACT
R 7	220 Ω ± 2 %	804 729	VAL	R 34	12 kΩ ± 2 %	804 750	VAL
R 8	10 Ω ± 2 %	804 713	VAL	R 35	3,9 kΩ ± 2 %	804 744	VAL
R 9	220 Ω ± 2 %	804 729	VAL	R 36	10 Ω ± 2 %	804 713	VAL
R 10	10 Ω ± 2 %	804 713	VAL	R 37	1,2 kΩ ± 2 %	804 738	VAL
R 11	6,8 kΩ ± 2 %	804 747	VAL	R 38	150 kΩ ± 2 %	804 763	VAL
R 12	1 kΩ ± 2 %	804 737	VAL	R 39	100 Ω ± 2 %	804 725	VAL
R 13	1 kΩ ± 2 %	804 737	VAL	R 40	3,9 kΩ ± 2 %	804 744	VAL
R 14	1 kΩ ± 2 %	804 737	VAL	R 41	12 kΩ ± 2 %	804 750	VAL
R 15	1,2 kΩ ± 2 %	804 738	VAL	R 42	270 Ω ± 2 %	804 730	VAL
R 16	4,7 kΩ ± 2 %	804 745	VAL	R 43	47 Ω ± 2 %	804 721	VAL
R 17	390 Ω ± 2 %	804 732	VAL	R 44	150 kΩ ± 2 %	804 763	VAL
R 18	47 Ω ± 2 %	804 721	VAL	R 45			
R 19	0 Ω	804 700	VAL	R 46	1,2 kΩ ± 2 %	804 738	VAL
R 20	1,2 kΩ ± 2 %	804 738	VAL	R 47	330 Ω ± 2 %	804 731	VAL
R 21	5,6 kΩ ± 2 %	804 746	VAL	R 48			
R 22				R 49	470 Ω ± 2 %	804 733	VAL
R 23	220 Ω ± 2 %	804 729	VAL	R 50			
R 24	0 Ω	804 700	VAL	R 51	470 Ω ± 2 %	804 733	VAL
R 25	6,8 kΩ ± 2 %	804 747	VAL	R 52	1,2 kΩ ± 2 %	804 738	VAL
R 26	390 Ω ± 2 %	804 732	VAL	R 53			
R 27	470 Ω ± 2 %	804 733	VAL	R 54	330 Ω ± 2 %	804 731	VAL
R 28	4,7 kΩ ± 2 %	804 745	VAL	R 55			
R 29				R 56			
R 30				R 57	1,2 kΩ ± 2 %	804 738	VAL
R 31				R 58	330 Ω ± 2 %	804 731	VAL
R 32	10 Ω ± 2 %	804 713	VAL	R 59			
R 33				R 60	1 kΩ ± 2 %	804 737	VAL

07				Schlumberger Meßgeräte GmbH Ingolstädter Straße 67a 8000 München 46			Schaltteilliste EL. PARTS LIST Benennung DESCRIPTION Bestückte Leiterplatte Typ: UHF-Divider		Liste besteht LIST CONSISTS aus OF 6 Blatt SHEETS		
06											
05											
04											
03	7088.142	18.9.87	Di	1986	Tag DATE	Name NAME	Bezeichnung Schlumberger PART. NO.	361 435 Sa	Blatt Nr SHEET NO.  4		
02	7088.74	11.6.87	Mo	geschr.	3.12.86	Dietrich	Hierzu Schaltplan SEE CIRCUIT DIAGRAM	213 041 S			
01	6088.65	4.12.86	Di	bearb.			Gerät:	4031			
---	6088.63	3.12.86	Di	gedr.							
Aus- gabe ISSUE	Änd.-Mittg. Nr. MODIFIC. NO.	Tag DATE	Name NAME								

Diese Zeichnung ist unser Eigentum. Vervielfältigung, unbefugte Verwertung, Mitteilung an andere ist strafbar und schadenersatzpflichtig.



1	2	3	4	5	6	7	8
Pos. REF. NO	Wert VALUE	Bezeichnung Schlumberger PART. NO.	Hersteller MANUFACT	Pos. REF. NO.	Wert VALUE	Bezeichnung Schlumberger PART. NO.	Hersteller MANUFACT
R 61	1 kΩ ± 2 %	804 737	VAL	R 88	5,6 kΩ ± 2 %	804 746	VAL
R 62				R 89	1,2 kΩ ± 2 %	804 738	VAL
R 63	5,6 kΩ ± 2 %	804 746	VAL	R 90	10 Ω ± 2 %	804 713	VAL
R 64	1,2 kΩ ± 2 %	804 738	VAL	R 91	220 Ω ± 2 %	804 729	VAL
R 65	220 Ω ± 2 %	804 729	VAL	R 92			
R 66	1 kΩ ± 2 %	804 737	VAL	R 93	10 Ω ± 2 %	804 713	VAL
R 67	10 Ω ± 2 %	804 713	VAL	R 94	0 Ω	804 700	VAL
R 68				R 95	0 Ω	804 700	VAL
R 69	5,6 kΩ ± 2 %	804 746	VAL	R 96	0 Ω	804 700	VAL
R 70	1,2 kΩ ± 2 %	804 738	VAL	R 97	0 Ω	804 700	VAL
R 71	10 Ω ± 2 %	804 713	VAL	R 98	0 Ω	804 700	VAL
R 72	220 Ω ± 2 %	804 729	VAL	R 99	0 Ω	804 700	VAL
R 73	1 kΩ ± 2 %	804 737	VAL	R 100	0 Ω	804 700	VAL
R 74				R 101	0 Ω	804 700	VAL
R 75	5,6 kΩ ± 2 %	804 746	VAL	R 102	0 Ω	804 700	VAL
R 76	1,2 kΩ ± 2 %	804 738	VAL	R 103	0 Ω	804 700	VAL
R 77	10 Ω ± 2 %	804 713	VAL	R 104			
R 78	10 Ω ± 2 %	804 713	VAL	R 105	0 Ω	804 700	VAL
R 79	220 Ω ± 2 %	804 729	VAL	R 106	0 Ω	804 700	VAL
R 80	1 kΩ ± 2 %	804 737	VAL				
R 81							
R 82	5,6 kΩ ± 2 %	804 746	VAL				
R 83	1,2 kΩ ± 2 %	804 738	VAL	R 110	1 kΩ ± 2 %	804 737	VAL
R 84	1 kΩ ± 2 %	804 737	VAL	R 111	1 kΩ ± 2 %	804 737	VAL
R 85	220 Ω ± 2 %	804 729	VAL	R 112	1 kΩ ± 2 %	804 737	VAL
R 86	10 Ω ± 2 %	804 713	VAL				
R 87							

07				Schlumberger Meßgeräte GmbH Ingolstädter Straße 67 a 8000 München 46			Schaltteilliste EL. PARTS LIST Bestückte Leiterplatte Typ: UHF-Divider		Liste besteht LIST CONSISTS		
06			Benennung DESCRIPTION								aus OF 6
05							Bezeichnung Schlumberger PART. NO		361 435 Sa		Blatt SHEETS
04							Hierzu Schaltplan SEE CIRCUIT DIAGRAM		213 041 S		Blatt Nr. SHEET NO. 5
03							Gerät: 4031				
02											
01	6088.65	4.12.86	Di	1986	Tag DATE	Name NAME					
---	6088.63	3.12.86	Di	geschr.	3.12.86	Dietrich					
Ausgabe ISSUE	Änd.-Mittig. Nr MODIFIC. NO.	Tag DATE	Name NAME	bearb. gepr.							

Diese Zeichnung ist unser Eigentum. Vervielfältigung, unbefugte Verwertung, Mitteilung an andere ist strafbar und schadenersatzpflichtig.



1	2	3	4	5	6	7	8
Pos. REF. NO.	Wert VALUE	Bezeichnung Schlumberger PART. NO.	Hersteller MANUFACT	Pos. REF. NO.	Wert VALUE	Bezeichnung Schlumberger PART. NO.	Hersteller MANUFACT
A 1	NE 5534 D	834 209	VAL	C 23	100 nF $\pm 10\%$ 50 V-	813 375	VAL
				C 24	2 2 pF $\pm 5\%$ 50 V-	813 227	VAL
				C 25	1 nF $\pm 10\%$ 50 V-	813 320	VAL
				C 26	22 pF $\pm 5\%$ 50 V-	813 227	VAL
				C 27	1 nF $\pm 10\%$ 50 V-	813 320	VAL
C 1	1 nF $\pm 10\%$ 50 V-	813 320	VAL				
C 2	2,2 $\mu$ F $\pm 20\%$ 50 V-	814 362	RÖD				
C 3	2,2 $\mu$ F $\pm 20\%$ 50 V-	814 362	RÖD	C 30	47 $\mu$ F $\pm 20\%$ 16 V-	814 386	RÖD
C 4	1 nF $\pm 10\%$ 50 V-	813 320	VAL	C 31	100 nF $\pm 10\%$ 50 V-	813 375	VAL
C 5	1 nF $\pm 10\%$ 50 V-	813 320	VAL	C 32	10 $\mu$ F $\pm 20\%$ 16 V-	814 382	RÖD
C 6	10 nF $\pm 10\%$ 50 V-	813 332	VAL	C 33	10 pF $\pm 5\%$ 50 V-	813 223	VAL
C 7	100 nF $\pm 10\%$ 50 V-	813 375	VAL	C 34	1 nF $\pm 10\%$ 50 V-	813 320	VAL
C 8	1 nF $\pm 10\%$ 50 V-	813 320	VAL	C 35	1 nF $\pm 10\%$ 50 V-	813 320	VAL
				C 36	3,3 pF $\pm 0,25\%$ 50 V-	813 217	VAL
C 10	10 nF $\pm 10\%$ 50 V-	813 332	VAL	C 37	1 nF $\pm 10\%$ 50 V-	813 320	VAL
C 11	10 $\mu$ F $\pm 20\%$ 16 V-	814 382	RÖD	C 38	1 nF $\pm 5\%$ 50 V-	813 247	VAL
C 12	1 nF $\pm 10\%$ 50 V-	813 320	VAL	C 39	2,2 nF $\pm 5\%$ 50 V-	813 251	VAL
C 13	1 nF $\pm 10\%$ 50 V-	813 320	VAL	C 40	100 pF $\pm 5\%$ 50 V-	813 235	VAL
C 14	10 $\mu$ F $\pm 20\%$ 16 V-	814 382	RÖD	C 41	1,2 nF $\pm 5\%$ 50 V-	813 248	VAL
C 15	47 $\mu$ F $\pm 20\%$ 16 V-	814 386	RÖD	C 42	100 pF $\pm 5\%$ 50 V-	813 235	VAL
C 16	39 pF $\pm 5\%$ 50 V-	813 230	VAL				
C 17	5,6 pF $\pm 0,25\%$ 50 V-	813 220	VAL				
C 18	1 nF $\pm 10\%$ 50 V-	813 320	VAL	G1 1	BA 885	830 533	SIE
C 19	1 nF $\pm 10\%$	813 320	VAL	G1 2	BA 885	830 533	SIE
C 20	100 pF $\pm 5\%$ 50 V-	813 235	VAL	G1 3	BA 885	830 533	SIE
C 21	100 nF $\pm 10\%$ 50 V-	813 375	VAL	G1 4	BB 609 B	830 621	VAL
C 22	100 nF $\pm 10\%$ 50 V-	813 375	VAL	G1 5	BB 609 B	830 621	VAL

07				Schlumberger Meßgeräte GmbH Ingolstädter Straße 67 a 8000 München 46			Schaltteilliste EL. PARTS LIST		Liste besteht LIST CONSISTS aus OF 3
06			Benennung DESCRIPTION Bestückte Leiterplatte						
05			Typ: Oszillator UHF-Synthese				Blatt Nr. SHEET NO 1		
04									
03									
02	7088.65	3.6.87	Mo.	1986	Tag DATE	Name NAME	Bezeichnung Schlumberger PART. NO 361 436 Sa		Blatt Nr. SHEET NO 1
01	7088.59	5.5.87	Di	geschr	19.6.86	Dietrich	Hierzu Schaltplan SEE CIRCUIT DIAGRAM 213 041 S		
--	7088.39	30.3.87	Mo.	bearb.		<i>ka</i>	Gerät: 4031		
Aus- gabe ISSUE	Änd.-Mittig. Nr. MODIFIC. NO	Tag DATE	Name NAME	gedr					

Diese Zeichnung ist unser Eigentum. Vervielfältigung, unbefugte Verwertung, Mitteilung an andere ist strafbar und schadenersatzpflichtig.

1	2	3	4	5	6	7	8
Pos. REF. NO.	Wert VALUE	Bezeichnung Schlumberger PART. NO.	Hersteller MANUFACT	Pos. REF. NO.	Wert VALUE	Bezeichnung Schlumberger PART. NO.	Hersteller MANUFACT
G1 6	BAT 17	830 516	VAL	R 13	56 $\Omega \pm 2\%$	804 722	VAL
				R 14	10 $\Omega \pm 2\%$	804 713	VAL
				R 15	10 $\Omega \pm 2\%$	804 713	VAL
L 1	100 $\mu\text{H} \pm 15\%$	821 322	SIE				
L 2	100 $\mu\text{H} \pm 15\%$	821 322	SIE				
L 3	560 nH $\pm 5\%$	821 224	STET	R 20	560 $\Omega \pm 2\%$	804 734	VAL
L 4	100 nH $\pm 5\%$	821 215	STET	R 21	220 $\Omega \pm 2\%$	804 729	VAL
L 5	100 nH $\pm 5\%$	821 215	STET	R 22	470 k $\Omega \pm 2\%$	804 769	VAL
L 6	1 $\mu\text{H} \pm 5\%$	821 227	STET	R 23	390 $\Omega \pm 2\%$	804 732	VAL
L 7	100 nH $\pm 5\%$	821 215	STET	R 24	100 $\Omega \pm 2\%$	804 725	VAL
L 8	68 nH $\pm 5\%$	821 213	STET	R 25	1 k $\Omega \pm 2\%$	804 737	VAL
L 9	820 nH $\pm 5\%$	821 226	STET	R 26	18 $\Omega \pm 2\%$	804 716	VAL
R 1	330 $\Omega \pm 2\%$	804 731	VAL				
R 2	2,2 k $\Omega \pm 2\%$	804 741	VAL				
R 3	5,6 k $\Omega \pm 2\%$	804 746	VAL	R 30	680 $\Omega \pm 2\%$	804 735	VAL
R 4	270 $\Omega \pm 2\%$	804 730	VAL	R 31	10 k $\Omega \pm 2\%$	804 749	VAL
R 5	56 k $\Omega \pm 2\%$	804 758	VAL	R 32	220 $\Omega \pm 2\%$	804 729	VAL
R 6	1 k $\Omega \pm 2\%$	804 737	VAL	R 33	12 k $\Omega \pm 2\%$	804 750	VAL
R 7	15 k $\Omega \pm 2\%$	804 751	VAL	R 34	1 k $\Omega \pm 2\%$	804 737	VAL
				R 35	270 $\Omega \pm 2\%$	804 730	VAL
				R 36	18 $\Omega \pm 2\%$	804 716	VAL
R 10	1 k $\Omega \pm 2\%$	804 737	VAL	R 37	18 $\Omega \pm 2\%$	804 716	VAL
R 11	1 k $\Omega \pm 2\%$	804 737	VAL				
R 12	1 k $\Omega \pm 2\%$	804 737	VAL				

07				Schlumberger Meßgeräte GmbH Ingolstädter Straße 67 a 8000 München 46			Schaltteilliste EL. PARTS LIST		Liste besteht LIST CONSISTS aus 3 OF Blatt SHEETS			
06										Benennung DESCRIPTION		Bestückte Leiterplatte Typ: Oszillator UHF-Synthese
05							1986	Tag DATE	Name NAME	Bezeichnung Schlumberger PART. NO.		Blatt Nr. SHEET NO 2
04							1986	19.6.86	Dietrich	361 436 Sa		
03							Hierzu Schaltplan SEE CIRCUIT DIAGRAM					
02							213 041 S					
01	7088.59	5.5.87	Di	geschr.			Gerät: 4031					
---	7088.39	30.3.87	Mo.	bearb.								
Ausgabe ISSUE	Änd.-Mittg. Nr. MODIFIC. NO.	Tag DATE	Name NAME	gepr.								

Diese Zeichnung ist unser Eigentum. Vervielfältigung, unbefugte Verwertung, Mitteilung an andere ist strafbar und schadenersatzpflichtig.











1	2			3	4	5	6		7	8			
Pos. REF. NO	Wert VALUE			Bezeichnung Schlumberger PART. NO.	Hersteller MANUFACT	Pos. REF. NO.	Wert VALUE		Bezeichnung Schlumberger PART. NO	Hersteller MANUFACT			
C 47	1,5 nF ± 5 % 50 V-			813 249	VAL	C 74	47 nF ± 10 % 50 V-		813 371	VAL			
C 48	15 pF ± 5 % 50 V-			813 225	VAL								
						C 76	100 pF ± 5 % 50 V-		813 235	VAL			
C 50	100 pF ± 5 % 50 V-			813 235	VAL								
C 51	1 nF ± 10 % 50 V-			813 320	VAL								
C 52	1 nF ± 10 % 50 V-			813 320	VAL								
C 53	1 nF ± 10 % 50 V-			813 320	VAL	C 80	100 nF ± 10 % 50 V-		813 375	VAL			
C 54	1 nF ± 10 % 50 V-			813 320	VAL	C 81	100 pF ± 5 % 50 V-		813 235	VAL			
C 55	1 nF ± 10 % 50 V-			813 320	VAL	C 82	100 nF ± 10 % 50 V-		813 375	VAL			
C 56	1 nF ± 10 % 50 V-			813 320	VAL	C 83	100 nF ± 10 % 50 V-		813 375	VAL			
						C 84	100 nF ± 10 % 50 V-		813 375	VAL			
						C 85	100 nF ± 10 % 50 V-		813 375	VAL			
						C 86	1 nF ± 10 % 50 V-		813 320	VAL			
C 60	1 nF ± 10 % 50 V-			813 320	VAL								
C 61	1 nF ± 10 % 50 V-			813 320	VAL								
C 62	1 nF ± 10 % 50 V-			813 320	VAL	C 89	1 nF ± 10 % 50 V-		813 320	VAL			
C 63	1 nF ± 10 % 50 V-			813 320	VAL	C 90	1 nF ± 10 % 50 V-		813 320	VAL			
C 64	22 pF ± 5 % 50 V-			813 227	VAL	C 91	1 nF ± 10 % 50 V-		813 320	VAL			
C 65	1 nF ± 10 % 50 V-			813 320	VAL	C 92	1 nF ± 10 % 50 V-		813 320	VAL			
C 66	33 pF ± 5 % 50 V-			813 229	VAL	C 93	10 µF ± 20 % 16 V-		814 382	RÖD			
						C 94	1 nF ± 10 % 50 V-		813 320	VAL			
						C 95	100 nF ± 10 % 50 V-		813 375	VAL			
						C 96	2,2 µF ± 20 % 50 V-		814 362	RÖD			
C 70	1 nF ± 10 % 50 V-			813 320	VAL								
C 71	1 nF ± 10 % 50 V-			813 320	VAL								
C 72	33 pF ± 5 % 50 V-			813 229	VAL								
C 73	47 nF ± 10 % 50 V-			813 371	VAL	C 100	10 µF ± 20 % 16 V-		814 382	RÖD			
07				Schlumberger Meßgeräte GmbH Ingolstädter Straße 67a 8000 München 46			Schaltteilliste EL. PARTS LIST Benennung DESCRIPTION Bestückte Leiterplatte Typ: PROG DIVIDER			Liste besteht LIST CONSISTS aus OF 9			
06			Blatt SHEETS										
05							Bezeichnung Schlumberger PART NO			361 439 Sa		Blatt Nr SHEET NO	
04							Hierzu Schaltplan SEE CIRCUIT DIAGRAM			213 041 S		2	
03				Name NAME			Dietrich						
02				Tag DATE			21.4.87						
01	7088,84	5.7.87	Di	1987	geschr	4031							
↔	7088,54	23.4.87	Staff		bearb								
Aus- gabe ISSUE	Änd.-Mittg. Nr MODIFIC. NO	Tag DATE	Name NAME	bearb gdr.									

Diese Zeichnung ist unser Eigentum. Vervielfältigung, unbefugte Verwertung, Mitteilung an andere ist strafbar und schadenersatzpflichtig.

1	2	3	4	5	6	7	8		
Pos. REF. NO.	Wert VALUE	Bezeichnung Schlumberger PART. NO.	Hersteller MANUFACT	Pos. REF. NO.	Wert VALUE	Bezeichnung Schlumberger PART. NO.	Hersteller MANUFACT		
C 101	10 nF $\pm$ 10 % 50 V-	813 332	VAL						
C 102	1,5 nF $\pm$ 5 % 50 V-	813 249	VAL						
C 103	1 nF $\pm$ 5 % 50 V-	813 247	VAL	C 130	2,7 nF $\pm$ 5 % 50 V-	813 252	VAL		
C 104	1,5 nF $\pm$ 5 % 50 V-	813 249	VAL	C 131	27 pF $\pm$ 5 % 50 V-	813 228	VAL		
C 105	100 nF $\pm$ 10 % 50 V-	813 375	VAL	C 132	10 $\mu$ F $\pm$ 20 % 16 V-	814 382	RÖD		
C 106	2,2 $\mu$ F $\pm$ 20 % 50 V-	814 362	RÖD	C 133	100 nF $\pm$ 10 % 50 V-	813 375	VAL		
				C 134	2,2 nF $\pm$ 20 % 50 V-	814 362	RÖD		
				C 135	2,2 nF $\pm$ 20 % 50 V-	814 362	RÖD		
				C 136	100 nF $\pm$ 10 % 50 V-	813 375	VAL		
C 110	2,2 $\mu$ F $\pm$ 20 % 50 V-	814 362	RÖD						
C 111	100 nF $\pm$ 10 % 50 V-	813 375	VAL						
C 112	100 nF $\pm$ 10 % 50 V-	813 375	VAL						
C 113	680 pF $\pm$ 5 % 50 V-	813 245	VAL	C 140	100 nF $\pm$ 10 % 50 V-	813 375	VAL		
C 114	100 pF $\pm$ 5 % 50 V-	813 235	VAL	C 141	100 nF $\pm$ 10 % 50 V-	813 375	VAL		
C 115	100 nF $\pm$ 10 % 50 V-	813 375	VAL						
C 116	100 nF $\pm$ 10 % 50 V-	813 375	VAL						
C 120	10 $\mu$ F $\pm$ 20 % 16 V-	814 382	RÖD	D 1	U 822 BS	834 428	TELE		
C 121	100 nF $\pm$ 10 % 50 V-	813 375	VAL	D 2	F 11 C 91 DC	834 421	FAIR		
C 122	100 nF $\pm$ 10 % 50 V-	813 375	VAL	D 3	SN 74 AS 74 D	834 449	TEX		
C 123	100 nF $\pm$ 10 % 50 V-	813 375	VAL	D 4	HD 100 102 F	834 493	HIT		
C 124	1 nF $\pm$ 5 % 50 V-	813 247	VAL	D 5	SN 74 AS 168 D	834 470	TEX		
C 125	100 nF $\pm$ 10 % 50 V-	813 375	VAL	D 6	U 822 BS	834 428	TELE		
C 126	47 nF $\pm$ 10 % 50 V-	813 371	VAL						
07				Schlumberger Meßgeräte GmbH Ingolstädter Straße 67a 8000 München 46			Schalteilliste EL. PARTS LIST Restückte Leiterplatte Typ: PROG DIVIDER	Liste besteht LIST CONSISTS	
06									aus OF 9
05									Blatt SHEETS
04									Blatt Nr SHEET NO
03									3
02				1987	Tag DATE	Name NAME	Bezeichnung Schlumberger PART. NO	361 439 Sa	
01	7088.84	5.7.87	Di	geschr	21.4.87	Dietrich	Hierzu Schaltplan SEE CIRCUIT DIAGRAM	213 041 S	
==	7088.54	23.4.87	Staff	bearb.		<i>LS</i>	Gerät:	4031	
Aus- gäbe ISSUE	Änd.-Mittig. Nr. MODIFIC. NO.	Tag DATE	Name NAME	bearb. gepr.					

Diese Zeichnung ist unser Eigentum. Vervielfältigung, unbefugte Verwertung, Mitteilung an andere ist strafbar und schadenersatzpflichtig.

1	2		3		4		5		6		7		8		
Pos. REF. NO.	Wert VALUE		Bezeichnung Schlumberger PART. NO.		Hersteller MANUFACT		Pos. REF. NO.	Wert VALUE		Bezeichnung Schlumberger PART. NO.		Hersteller MANUFACT			
							G1 5	BAS 16		830 552		VAL			
D 10	F 11 C 91 DC		834 421		FAIR		G1 6	BAV 99		830 491		VAL			
D 11	F 11 C 91 DC		834 421		FAIR										
D 12	MC 10 H 131 P		834 494		MOT										
D 13	74 AS 168 D		834 470		TEX										
D 14	PC 74 HCT 4046 AT		834 440		VAL										
D 15	SN 74 AS 74 D		834 449		TEX		G1 11	BAV 99		830 491		VAL			
D 16	SN 74 AS 74 D		834 449		TEX		G1 12	LSS 250		856 200		SIE			
							G1 13	HSMS-2910		830 551		HP			
D 20	SN 74 AS 74 D		834 449		TEX										
D 21	SN 74 AS 74 D		834 449		TEX										
D 22	SN 74 AS 74 D		834 449		TEX										
							L 1	10 nH $\pm$ 20 %		821 207		STET			
D 24	SN 74 AS 30 D		834 495		TEX										
D 25	PC 74 HCT 00 T		834 430		VAL		L 3	150 nH $\pm$ 5 %		821 217		STET			
D 26	PC 74 HCT 00 T		834 430		VAL		L 4	150 nH $\pm$ 5 %		821 217		STET			
							L 5	330 nH $\pm$ 5 %		821 221		STET			
							L 6	330 nH $\pm$ 5 %		821 221		STET			
G1 1	BAS 16		830 552		HP		L 10	22 nH $\pm$ 20 %		821 208		STET			
G1 2	BZX 84 C 5 V 1		830 492		VAL										
G1 3	BZX 84 C 5 V 1		830 492		VAL		L 12	820 nH $\pm$ 5 %		821 226		STET			
G1 4	HSMS-2910		830 551		HP		L 13	1,5 $\mu$ H $\pm$ 10 %		821 229		STET			
07					Schlumberger Meßgeräte GmbH Ingolstädter Straße 67 a 8000 München 46			Schaltteilliste EL. PARTS LIST				Liste besteht LIST CONSISTS aus 9 OF			
06				Benennung DESCRIPTION										Bestückte Leiterplatte Typ: PROG DIVIDER	
05								Bezeichnung Schlumberger PART NO				361 439 Sa		Blatt Nr SHEET NO	
04								Hierzu Schaltplan SEE CIRCUIT DIAGRAM				213 041 S		4	
03								Gerät: 4031							
02															
01	7088.84	5.7.87	Di	1987	Tag DATE	Name NAME									
--	7088.54	23.4.87	Staff	geschr	21.4.87	Dietrich									
Aus- gabe ISSUE	And-Mittig Nr. MODIFIC. NO	Tag DATE	Name NAME	gepr.		<i>Le</i>									

Diese Zeichnung ist unser Eigentum. Vervielfältigung, unbefugte Verwertung, Mitteilung an andere ist strafbar und schadenersatzpflichtig.

1	2		3		4	5	6		7		8	
Pos. REF NO	Wert VALUE		Bezeichnung Schlumberger PART NO.		Hersteller MANUFACT	Pos. REF NO	Wert VALUE		Bezeichnung Schlumberger PART NO		Hersteller MANUFACT	
L 14	820 nH $\pm$ 5 %		821 226		STET							
L 15	1 $\mu$ H $\pm$ 5 %		821 227		SIET							
L 16	1 $\mu$ H $\pm$ 5 %		821 227		STET							
						R 1	220 $\Omega$ $\pm$ 2 %		804 729		VAL	
						R 2	22 $\Omega$ $\pm$ 2 %		804 717		VAL	
						R 3	220 $\Omega$ $\pm$ 2 %		804 729		VAL	
L 20	180 nH $\pm$ 5 %		821 218		STET	R 4	560 $\Omega$ $\pm$ 2 %		804 734		VAL	
L 21	180 nH $\pm$ 5 %		821 218		STET	R 5	1,5 k $\Omega$ $\pm$ 2 %		804 739		VAL	
L 22	180 nH $\pm$ 5 %		821 218		STET	R 6	1,5 k $\Omega$ $\pm$ 2 %		804 739		VAL	
L 23	180 nH $\pm$ 5 %		821 218		STET	R 7	12 k $\Omega$ $\pm$ 2 %		804 750		VAL	
L 24	100 $\mu$ H $\pm$ 15 %		821 322		SIE	R 8	1,8 k $\Omega$ $\pm$ 2 %		804 740		VAL	
L 25	220 nH $\pm$ 5 %		821 219		SIE							
L 26	22 $\mu$ H $\pm$ 15 %		821 318		SIE	P 10	10 k $\Omega$ $\pm$ 2 %		804 749		VAL	
						R 11	1,8 k $\Omega$ $\pm$ 2 %		804 740		VAL	
						R 12	330 $\Omega$ $\pm$ 2 %		804 731		VAL	
						R 13	100 $\Omega$ $\pm$ 2 %		804 725		VAL	
L 30	1 $\mu$ H $\pm$ 15 %		821 310		SIE	R 14	560 $\Omega$ $\pm$ 2 %		804 734		VAL	
L 31	1 $\mu$ H $\pm$ 15 %		821 310		SIE	R 15	1,5 k $\Omega$ $\pm$ 2 %		804 739		VAL	
						R 16	470 $\Omega$ $\pm$ 2 %		804 733		VAL	
						R 17	330 $\Omega$ $\pm$ 2 %		804 731		VAL	
						R 18	100 $\Omega$ $\pm$ 2 %		804 725		VAL	
						R 20	1 k $\Omega$ $\pm$ 2 %		804 737		VAL	
Mi 1	SMD-C 1		872 081		SYN	R 21	100 $\Omega$ $\pm$ 2 %		804 725		VAL	
Mi 2	SMD-C 1		872 081		SYN	R 22	680 $\Omega$ $\pm$ 2 %		804 735		VAL	
						R 23	15 k $\Omega$ $\pm$ 2 %		804 751		VAL	
						R 24	1 k $\Omega$ $\pm$ 2 %		804 737		VAL	
07					<b>Schlumberger Meßgeräte GmbH</b> Ingolstädter Straße 67a 8000 München 46						Liste besteht LIST CONSISTS	
06											<b>Schalteilliste</b> EL. PARTS LIST	
05					Benennung DESCRIPTION <b>Poststücke Leiterplatte</b> Typ: PROG DIVIDER						Blatt SHEETS	
04											Bezeichnung Schlumberger PART NO.	
03					1987 Tag DATE Name NAME geschr. 21.4.87 Dietrich bearb. <i>KL</i> gepr.						5	
02											Hierzu Schaltplan SEE CIRCUIT DIAGRAM 213 041 S Gerät: 4031	
01	7088 84	5.7.87	Di									
---	7088 54	23.4.87	Staff									
Aus- gabe ISSUE	Änd- Nr. MODIFIC. NO.	Tag DATE	Name NAME									

Diese Zeichnung ist unser Eigentum. Vervielfältigung, unbefugte Verwertung, Mitteilung an andere ist strafbar und schadenersatzpflichtig.

1	2	3	4	5	6	7	8
Pos. REF. NO	Wert VALUE	Bezeichnung Schlumberger PART. NO.	Hersteller MANUFACT	Pos. REF. NO	Wert VALUE	Bezeichnung Schlumberger PART. NO	Hersteller MANUFACT
				R 52	68 Ω ± 2 %	804 723	VAL
R 26	18 Ω ± 2 %	804 716	VAL	R 53	220 Ω ± 2 %	804 729	VAL
R 27	390 Ω ± 2 %	804 732	VAL	R 54	1 kΩ ± 2 %	804 737	VAL
R 28	1,8 kΩ ± 2 %	804 740	VAL	R 55	150 Ω ± 2 %	804 727	VAL
				R 56	39 Ω ± 2 %	804 720	VAL
R 30	100 Ω ± 2 %	804 725	VAL				
R 31	680 Ω ± 2 %	804 735	VAL				
R 32	180 Ω ± 2 %	804 728	VAL				
R 33	1,2 kΩ ± 2 %	804 738	VAL	R 60	150 Ω ± 2 %	804 727	VAL
R 34	680 Ω ± 2 %	804 735	VAL	R 61	220 Ω ± 2 %	804 729	VAL
R 35	22 kΩ ± 2 %	804 753	VAL	R 62	1 kΩ ± 2 %	804 737	VAL
R 36	22 kΩ ± 2 %	804 753	VAL	R 63	4,7 kΩ ± 2 %	804 745	VAL
R 37	10 kΩ ± 2 %	804 749	VAL	R 64	6,8 kΩ ± 2 %	804 747	VAL
R 38	2,2 kΩ ± 2 %	804 741	VAL	R 65	2,2 kΩ ± 2 %	804 741	VAL
R 39	22 kΩ ± 2 %	804 753	VAL	R 66	56 Ω ± 2 %	804 722	VAL
R 40	10 kΩ ± 2 %	804 749	VAL				
R 41	1,8 kΩ ± 2 %	804 740	VAL				
R 42	1,8 kΩ ± 2 %	804 740	VAL				
R 43	330 Ω ± 2 %	804 731	VAL	R 70	470 Ω ± 2 %	804 733	VAL
R 44	100 Ω ± 2 %	804 725	VAL	R 71	470 Ω ± 2 %	804 733	VAL
R 45	680 Ω ± 2 %	804 735	VAL	R 72	470 Ω ± 2 %	804 733	VAL
R 46	100 Ω ± 2 %	804 725	VAL	R 73	1 kΩ ± 2 %	804 737	VAL
				R 74	1 kΩ ± 2 %	804 737	VAL
				R 75	470 Ω ± 2 %	804 733	VAL
				R 76	150 kΩ ± 2 %	804 763	VAL
R 50	68 Ω ± 2 %	804 723	VAL				
R 51	150 Ω ± 2 %	804 727	VAL				

07				Schlumberger Meßgeräte GmbH Ingolstädter Straße 67a 8000 München 46			Schaltteilliste EL. PARTS LIST		Liste besteht LIST CONSISTS		
06			Benennung DESCRIPTION							Bestückte Leiterplatte Typ: PROG DIVIDER	
05											Blatt SHEETS
04											Blatt Nr. SHEET NO
03											
02				Tag DATE	Name NAME	Bezeichnung Schlumberger PART NO		6			
01	7088.84	5.7.87	Di	1987		361 439 Sa					
--	7088.54	23.4.87	Staff	geschr	21.4.87	Dietrich					
Aus- gabe ISSUE	Änd.-Mittig. Nr. MODIFIC. NO.	Tag DATE	Name NAME	bearb gepr		Hierzu Schellplan SEE CIRCUIT DIAGRAM					
						213 041 S					
						Gerät: 4031					

Diese Zeichnung ist unser Eigentum. Vervielfältigung, unbefugte Verwertung, Mitteilung an andere ist strafbar und schadenersatzpflichtig.

1	2			3	4	5	6		7	8	
Pos. REF. NO.	Wert VALUE			Bezeichnung Schlumberger PART. NO.	Hersteller MANUFACT	Pos. REF. NO.	Wert VALUE		Bezeichnung Schlumberger PART. NO.	Hersteller MANUFACT	
						R 106	1 kΩ ± 2 %		804 737	VAL	
R 80	1 kΩ ± 2 %			804 737	VAL						
R 81	150 kΩ ± 2 %			804 763	VAL						
R 82	1 kΩ ± 2 %			804 737	VAL						
R 83	1 kΩ ± 2 %			804 737	VAL	R 110	4,7 kΩ ± 2 %		804 745	VAL	
R 84	1 kΩ ± 2 %			804 737	VAL	R 111	4,7 kΩ ± 2 %		804 745	VAL	
R 85	150 Ω ± 2 %			804 727	VAL	R 112	390 Ω ± 2 %		804 732	VAL	
R 86	2,2 kΩ ± 2 %			804 741	VAL	R 113	4,7 kΩ ± 2 %		804 745	VAL	
						R 114	4,7 kΩ ± 2 %		804 745	VAL	
						R 115	1 MΩ ± 2 %		804 773	VAL	
						R 116	12 kΩ ± 2 %		804 750	VAL	
R 90	2,2 kΩ ± 2 %			804 741	VAL						
R 91	68 Ω ± 2 %			804 723	VAL						
R 92	68 Ω ± 2 %			804 723	VAL						
R 93	10 kΩ ± 2 %			804 749	VAL	R 120	1 MΩ ± 2 %		804 773	VAL	
R 94	4,7 kΩ ± 2 %			804 745	VAL	R 121	2 kΩ ± 25 %		807 738	BOUR	
R 95	4,7 kΩ ± 2 %			804 745	VAL	R 122	1 kΩ ± 2 %		804 737	VAL	
R 96	1 kΩ ± 2 %			804 737	VAL	R 123	1 kΩ ± 2 %		804 737	VAL	
						R 124	100 Ω ± 2 %		804 725	VAL	
						R 125	10 kΩ ± 2 %		804 749	VAL	
						R 126	22 kΩ ± 2 %		804 753	VAL	
R 100	1 kΩ ± 2 %			804 737	VAL						
R 101	8,2 kΩ ± 2 %			804 748	VAL						
R 102	390 Ω ± 2 %			804 732	VAL						
R 103	8,2 kΩ ± 2 %			804 748	VAL	R 130	2,2 kΩ ± 2 %		804 741	VAL	
R 104	12 kΩ ± 2 %			804 750	VAL	R 131	680 Ω ± 2 %		804 735	VAL	
R 105	12 kΩ ± 2 %			804 750	VAL	R 132	100 Ω ± 2 %		804 725	VAL	
07				Schlumberger Meßgeräte GmbH Ingolstädter Straße 67a 8000 München 46			Schaltteilliste EL. PARTS LIST Benennung DESCRIPTION Bestückte Leiterplatte Typ: PROG DIVIDER			Liste besteht LIST CONSISTS	
06			aus OF 9								
05							Blatt SHEETS				
04							Blatt Nr SHEET NO				
03											
02											
01	7088.84	5.7.87	Di	1987	Tag DATE	Name NAME	Bezeichnung Schlumberger PART NO 361 439 Sa				
--	7088.54	23.4.87	Staff	geschr	21.4.87	Dietrich	Hierzu Schaltplan SEE CIRCUIT DIAGRAM 213 041 S		7		
Aus- gabe ISSUE	Änd.-Mittig Nr MODIFIC. NO.	Tag DATE	Name NAME	bearb gepr.		<i>[Signature]</i>	Gerät: 4031				

Diese Zeichnung ist unser Eigentum Vervielfältigung, unbefugte Verwertung, Mitteilung an andere ist strafbar und schadenersatzpflichtig.

1	2		3		4		5		6		7		8	
Pos. REF. NO	Wert VALUE		Bezeichnung Schlumberger PART. NO.		Hersteller MANUFACT		Pos. REF. NO	Wert VALUE		Bezeichnung Schlumberger PART. NO		Hersteller MANUFACT		
R 133	390	$\Omega \pm 2\%$	804	732	VAL		R 160	22	$k\Omega \pm 2\%$	804	753	VAL		
R 134	2,2	$k\Omega \pm 2\%$	804	741	VAL		R 161	22	$k\Omega \pm 2\%$	804	753	VAL		
R 135	10	$k\Omega \pm 2\%$	804	749	VAL									
R 136	2,2	$k\Omega \pm 2\%$	804	741	VAL									
R 140	22	$k\Omega \pm 2\%$	804	753	VAL		T 1	BFR 93	A	832	287	VAL		
R 141	22	$k\Omega \pm 2\%$	804	753	VAL		T 2	BFT 93		832	293	VAL		
R 142	2,2	$k\Omega \pm 2\%$	804	741	VAL		T 3	BFR 93	A	832	287	VAL		
R 143	10	$k\Omega \pm 2\%$	804	749	VAL		T 4	BC 850	B	832	284	VAL		
R 144	2,2	$k\Omega \pm 2\%$	804	741	VAL		T 5	BFR 93	A	832	287	VAL		
R 145	22	$k\Omega \pm 2\%$	804	753	VAL		T 6	BFR 93	A	832	287	VAL		
R 146	22	$k\Omega \pm 2\%$	804	753	VAL									
							T 10	BFR 93	A	832	287	VAL		
R 150	10	$k\Omega \pm 2\%$	804	749	VAL		T 11	BFR 93	A	832	287	VAL		
R 151	2,2	$k\Omega \pm 2\%$	804	741	VAL		T 12	BFT 93		832	293	VAL		
R 152	22	$k\Omega \pm 2\%$	804	753	VAL		T 13	BFR 93	A	832	287	VAL		
R 153	22	$k\Omega \pm 2\%$	804	753	VAL		T 14	SST 175		832	288	SILIC		
R 154	680	$\Omega \pm 2\%$	804	735	VAL		T 15	BC 850	B	832	284	VAL		
R 155	680	$\Omega \pm 2\%$	804	735	VAL		T 16	BC 860	B	832	285	VAL		
R 156	2,2	$k\Omega \pm 2\%$	804	741	VAL		T 17	BFR 93	A	832	287	VAL		
R 157	1	$k\Omega \pm 2\%$	804	737	VAL		T 18	BC 850	B	832	284	VAL		
							T 19	BC 850	B	832	284	VAL		
							T 20	BC 860	E	832	285	VAL		

07					Schlumberger Meßgeräte GmbH Ingolstädter Straße 67a 8000 München 46			Schaltteilliste EL. PARTS LIST Benennung DESCRIPTION Bestückte Leiterplatte Typ: PROG DIVIDER			Liste besteht LIST CONSISTS	
06				Aus OF							3	
05				Blatt SHEETS								
04				Blatt Nr SHEET NO								
03												
02							Bezeichnung Schlumberger PART NO			361 439 Sa		
01	7088,84	5,7,87	Di	1987	Tag DATE	Name NAME	Hierzu Schaltplan SEE CIRCUIT DIAGRAM			213 041 S		
	7088,54	23,4,87	Staff	geschr	21.4.87	Dietrich	Gerät:			4031		
Aus- gabe ISSUE	Änd- Nr MODIFIC NO	Tag DATE	Name NAME	bearb gedr.		<i>LD</i>				8		

Diese Zeichnung ist unser Eigentum. Vervielfältigung, unbefugte Verwertung, Mitteilung an andere ist strafbar und schadenersatzpflichtig.





### 1. Frequency modulator 361 457

The frequency-modulated oscillator T5 works at a frequency of 105.6 MHz. It is held on its centre frequency by a narrowband PLL (D8, D9, A4, G14, G15).

The control and modulation voltages are added on varactors G14/5. The modulation sensitivity can be adjusted with R65 and reduced by a factor of four for certain RF bands with T11, T10.

As a function of the FM mode the source for the reference frequency of the PLL is selected with gates D5:

In AC FM mode it is derived from the crystal-referenced 10-MHz signal on socket Bu2 by division (D7). At the same time D7 generates the reference frequency for the fine decade 361 455 (Bu3).

In DC FM mode it is derived from crystal oscillator T2/Qu1, the frequency of which is in turn referred by a PLL (D1, A1, G11, G12) to the 10-MHz crystal signal divided down to 400 kHz by D7.

In DC frequency modulation the modulation voltage on socket Bu8 produces on the one hand a change in the frequency of the FM oscillator (T5), and on the other hand it is converted via the active lowpass filter A2 by the A/D converter into a binary word that drives the phase accumulator in gate array D2. In this way it is possible to divide the frequency of crystal oscillator T2 to 400 kHz with a small decrement/increment as a function of the modulation voltage.

The change in frequency of the 400-kHz reference is matched to the deviation of the FM oscillator with potentiometers R20, R21. The monoflops D4-A/B form the clock generator for the gate array (D2) and the A/D converter (D3).

Ref.No. 217 031 F	Sub FM Modulator	Date 9.4.87
Type 4031	Unit	Sheet 1/2
Schlumberger		Functional Description

## 2. Fine decade 361 455

Oscillator D2 of the fine decade is integrated into a PLL (D3, D4, A1, G13-6) and can be tuned between 56 and 76 MHz in 1-kHz increments. The division ratio is transferred serially on the data line with the clock to synthesizer device D4 when the input is enabled.

Amplifier T1 boosts the signal level for driving frequency divider D1, at the output of which the divided oscillator signal appears in 100-Hz increments in the range 5.6 to 7.6 MHz.

If the PLL is unsynchronized, transistor T2 signals the error with H level on socket Bu10.

## 3. Adding loop 361 456

Oscillator T6 is held to the sum frequency of the fine decade and FM modulator by a PLL (T6, T2, A1, D1, A3, G12, G13).

Transistor T2 works as a multiplying mixer with preceding impedance transformers (T1, T4), the filtered output signal of which (C15, C14, L1, C13, L6, C20) is increased to TTL level by level converter A1.

Comparator A2-A and transistor T10 prevent the PLL from locking onto the image frequency by charging integrator A3-A in the capture operation.

If there is a deviation from a given range of control voltage, comparator A2-B signals this via T1 and socket Bu8 as an impermissible operating state.

The oscillator signal, buffered by amplifier T5, is applied to divider D2, which divides the frequency by a factor of ten.

In analyzer mode the divider is disabled via socket Bu6.

Ref.No. 217 031 F	Sub FM Modulator	Date 9.4.87
Type 4031	Unit	Sheet 2/2
Schlumberger		Functional Description

Necessary Equipment		Measuring Procedure				Measuring Point	Frequency	Adjustment	Set Value	Actual Value
4031	Frequency counter	Connect FM modulator 217 031 by extension to 4031 a) Frequency modulator 361 457 1. Divider 10 MHz : 25 10 MHz : 4 2. Clock oscillator Frequency Varactor voltage 3. DC FM Test setup: Frequency counter must be synchronized with 4031's internal 10-MHz xtal oscillator via Bu13				D7/6 Bu3	400 kHz 2.5 MHz		400 kHz 2.5 MHz	
DVM						D1/4 A1/1	3.263745 MHz DC		3.263745 MHz -1 to -8 V	
Issue		Alteration No.	Date	Name	Alteration No.	Date	Ref. No. 217 031 A		Sheet	
-	6099-78		15.5.88				Sub Unit FM Modulator		1/5	
							Type STABILLOCK 4031			

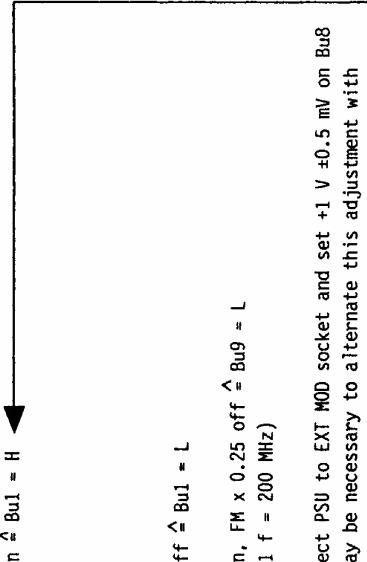
Schlumberger		Adjustment and Test Procedure							Sheet			
Necessary Equipment	Measuring Procedure	Measuring Point	Frequency	Adjustment	Set Value	Actual Value	Issue	Alteration No.	Date	Name		
							Alteration No.	Date	Name	Ref. No.	Type	Sub Unit
(PLL filter) Frequency counter (0.01 Hz resolution) eg Racal 1992	<p>RX FM input Bu8 to GND            DC on Bu1 = H</p>  <p>DC off Bu1 = L</p> <p>DC on, FM x 0.25 off Bu9 = L            (4031 f = 200 MHz)</p> <p>Connect PSU to EXT MOD socket and set +1 V ±0.5 mV on Bu8            It may be necessary to alternate this adjustment with 400-kHz adjustment (Bu8 on GND)</p> <p>Set -1 V ±0.5 mV on Bu8            FM x 0.25 on Bu9 = H (4031 f = 500 MHz)            Set -1 V ±0.5 mV on Bu8            Set +1 V ±0.5 mV on Bu8</p>	D9/2 D5/6 D5/8 D5/8 D5/6	400 kHz 400 kHz DC 400 kHz DC	R22 R20 rough R19 fine	400 kHz ±0.5 Hz 400 kHz > 2 V ± H 400 kHz > 2 V ± H 400758 ±0.5 Hz 399242 ±5 Hz 399811 ±2 Hz 400189 ±2 Hz		8088.78	15.5.88			217 031 A	STABILOCK 4031

Schlumberger		Adjustment and Test Procedure										Sheet				
Necessary Equipment	Measuring Procedure	Measuring Point	Frequency	Adjustment	Set Value	Actual Value	Issue	Alteration No.	Date	Name	Alteration No.	Date	Name	Ref. No.	Sub Unit	Sheet
							-	-	-	-	-	-	-	-	-	-
	<p>4. FM oscillator 105.6 MHz DC off/FM x 0.25 off (200 MHz) Separate 10-MHz i/p frequency Bu2 G110 lights <math>\hat{=}</math> unsynchronized Connect 10 MHz again DVM on A4/1 Turn core (821 916) in L5 until:- G110 off <math>\hat{=}</math> synchronized</p> <p>b) Fine decade 361.455 4031 f = 259.8499 MHz G12 lights <math>\hat{=}</math> unsynchronized Oscillator signal</p> <p>G12 off = synchronized Vcontrol</p>	Bu4 A4/1 Bu4 Bu10 Bu10	DC DC DC 105.6 MHz 105.6 MHz	L5	> 2 V $\hat{=}$ H  +10 $\pm$ 0.1 V < 0.8 V $\hat{=}$ L 105.6 MHz approx. 0.7 V <sub>pp</sub>									217 031 A	FM Modulator	3/5
Oscilloscope 100 MHz		Bu6 Bu10 Mp2	5.602 MHz DC $\approx$ 50 MHz		5.602 MHz > 2 V $\hat{=}$ H  > +5 V < 0 V											
Frequency counter, DVM		Bu10 Mp3	DC DC		< 0.8 V $\hat{=}$ L < -4 V											
							8011-78		15.5.88						STABLOCK 4031	

Necessary Equipment	Measuring Procedure	Measuring Point	Frequency	Adjustment	Set Value	Actual Value	Ref. No. 217 031 A				Sub Unit	Sheet	
							Issue	Name	Date	Type			
Oscilloscope	<p>4031 f = 259.8500 MHz (G12 off) V control Set min. pulse width or ± transition</p> <p>c) Adding loop 361 456 G14 lights Δ unsynchronized (L3 without core) 4031 f = 259.9 MHz Δ 6.6 MHz on Bu1 + 105.6 MHz on Bu5 Turn core (821 916) in L3 until G14 off Δ synchronized.</p>	Bu6 Mp3 Mp4	7.600 MHz DC	R33	7.600 MHz > +2 V Min. pulse/±		Issue	15.5.88					
Oscilloscope	<p>Output voltage Output frequency 4031 f = 259.8499 MHz Δ 5.602 MHz on Bu1 4031 f = 259.8500 MHz Δ 7.6 MHz on Bu1</p> <p>4031: analyzer function on Δ Bu6 = H then analyzer function off again Δ Bu6 = L</p>	Bu8 Mp2 Bu8 Bu7 Bu7 Bu7 Bu7 Bu7	DC DC DC DC 11.22 MHz 11.22 MHz 11.12 MHz 11.32 MHz	L3	> 2 V Δ H -8.5 ±0.1 V < 0.8 V Δ L approx. 0.3 V <sub>pp</sub> 11.22 MHz 11.12 MHz 11.32 MHz Signal on/off		Issue						



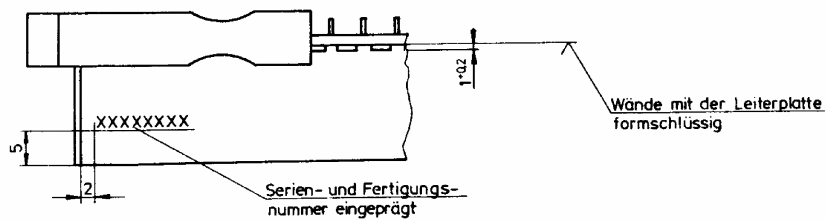
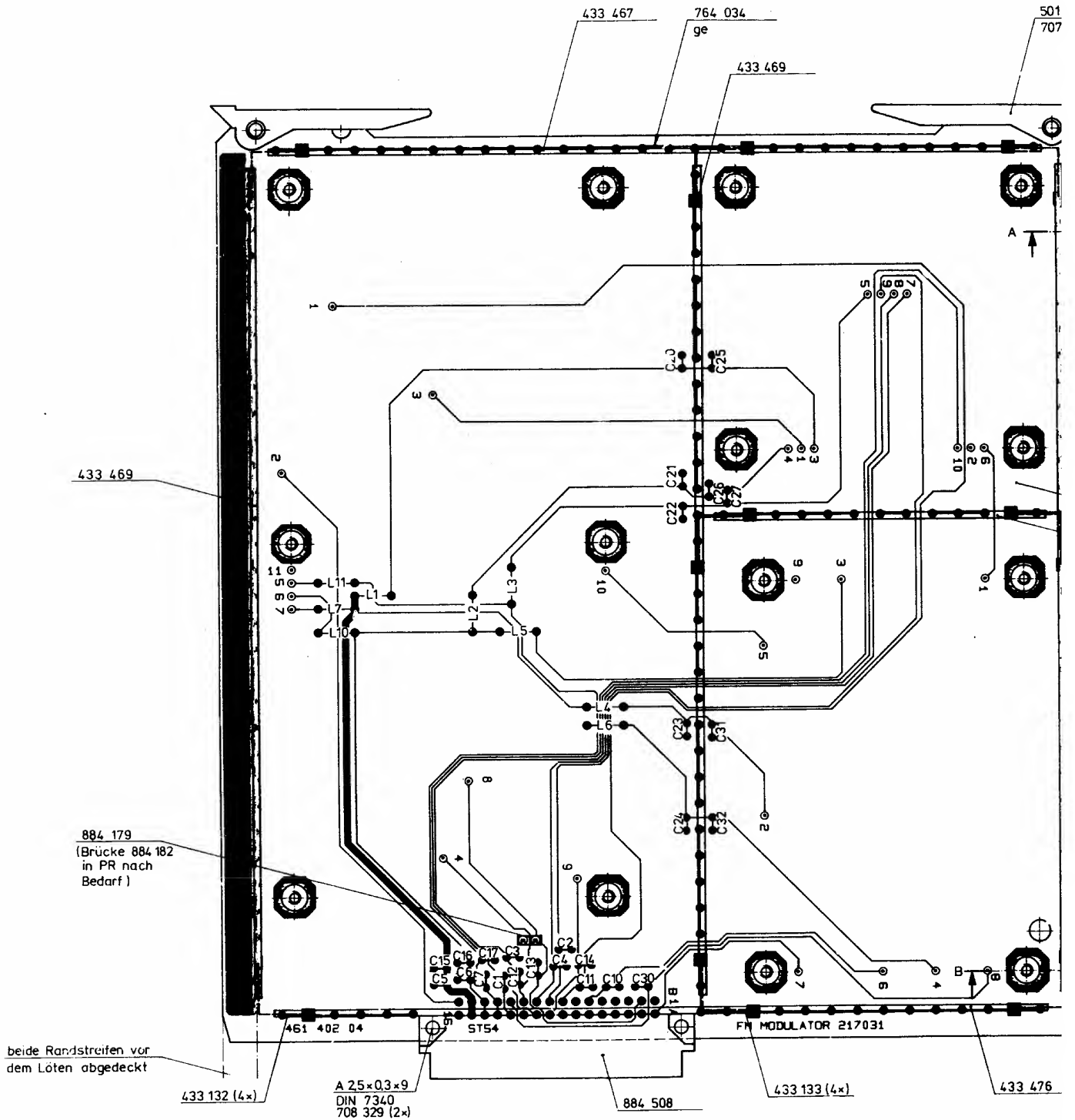

Positionierung = 217 031 S / 361 402 Sa

verwendet in:

12 11 10 9 8 7





ST54

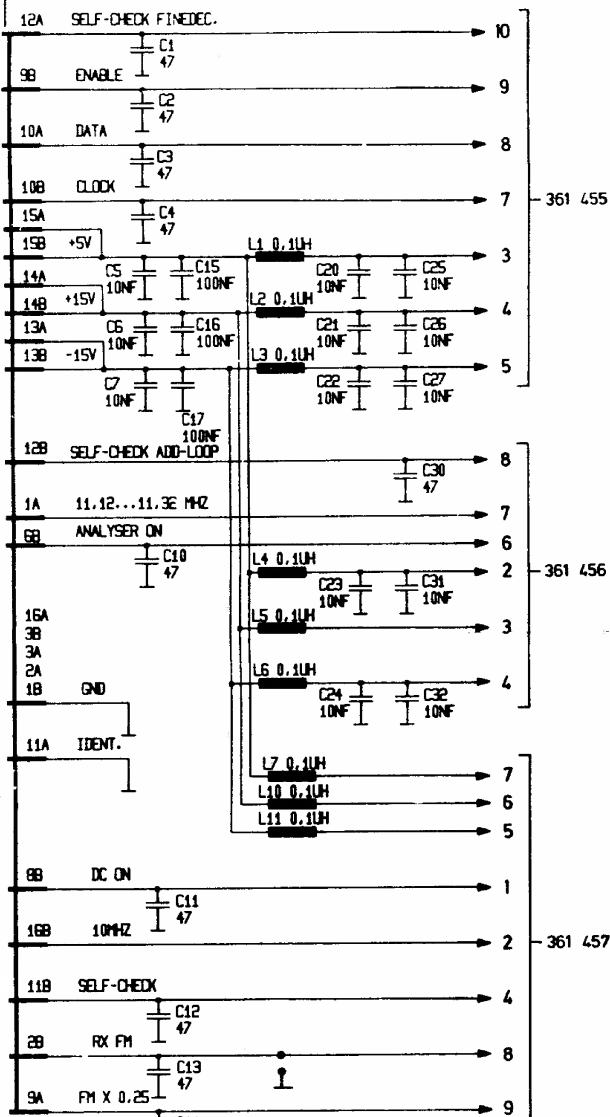

**BASIS FM-MODULATOR**  
361 402  
461 402 04

**FINE DECADE**  
361 455  
461 455 04

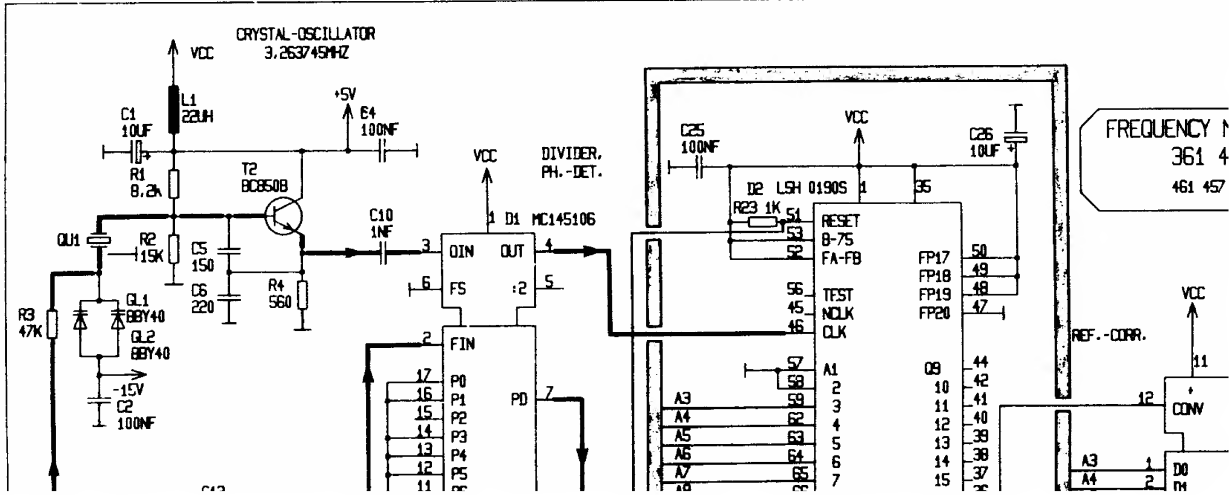
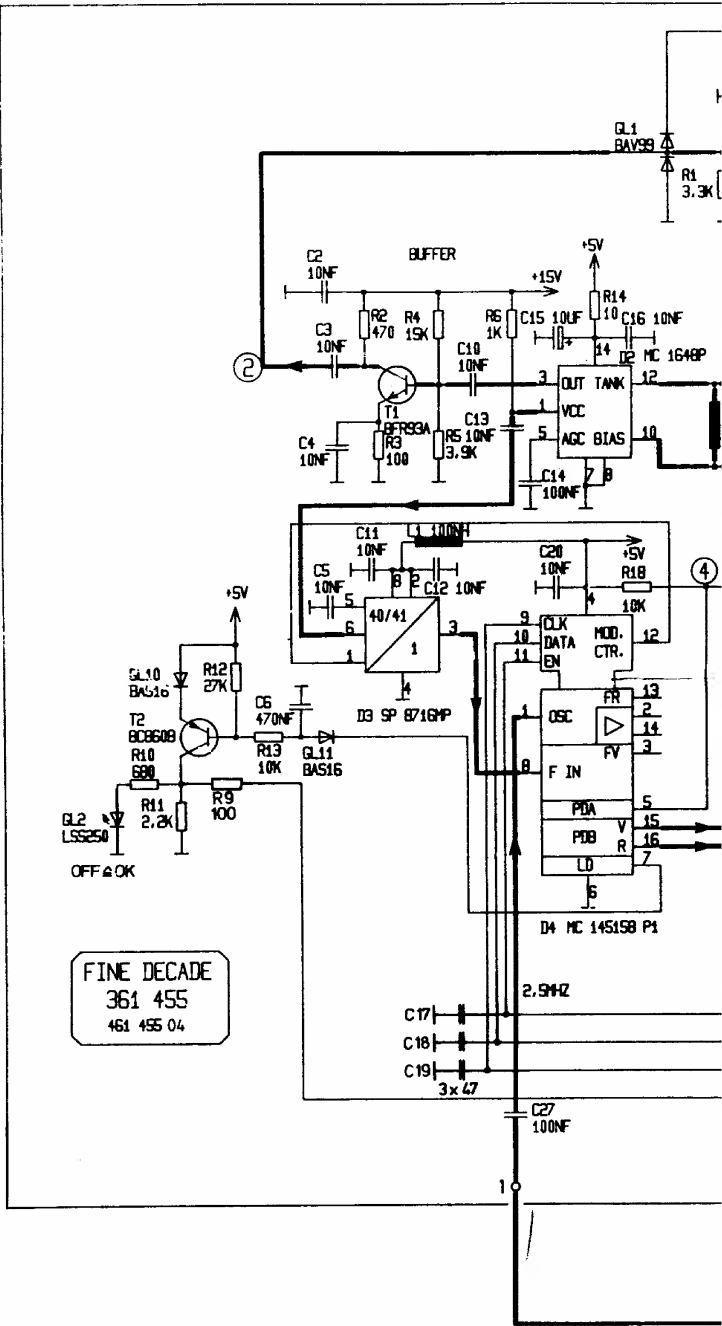

**FREQUENCY**  
361 4  
461 457

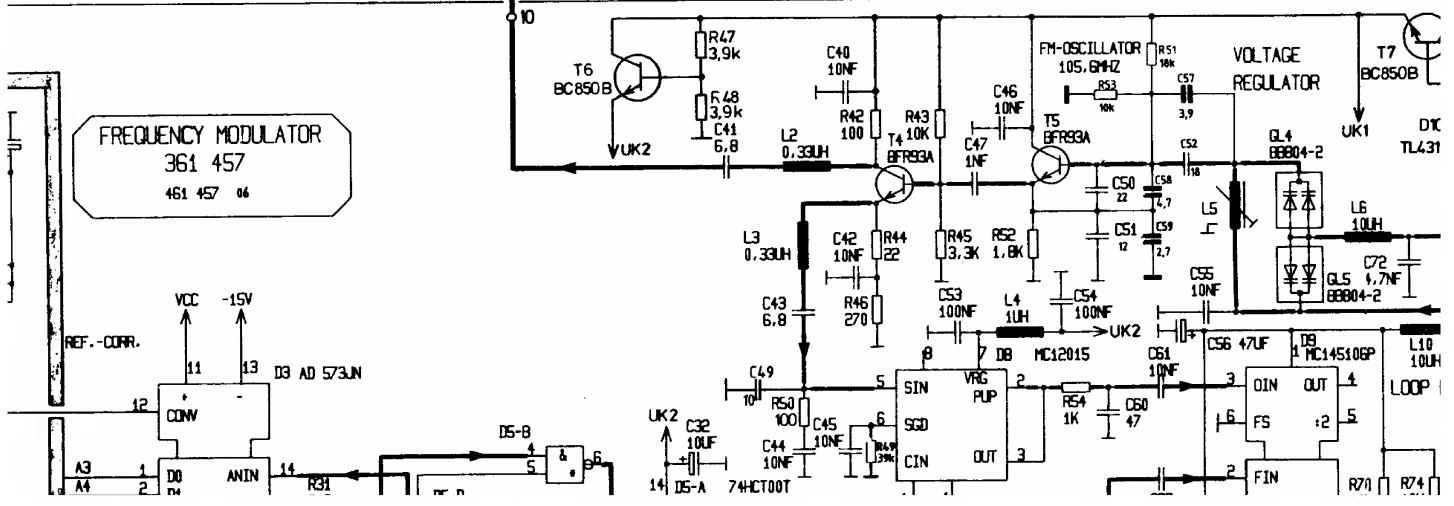
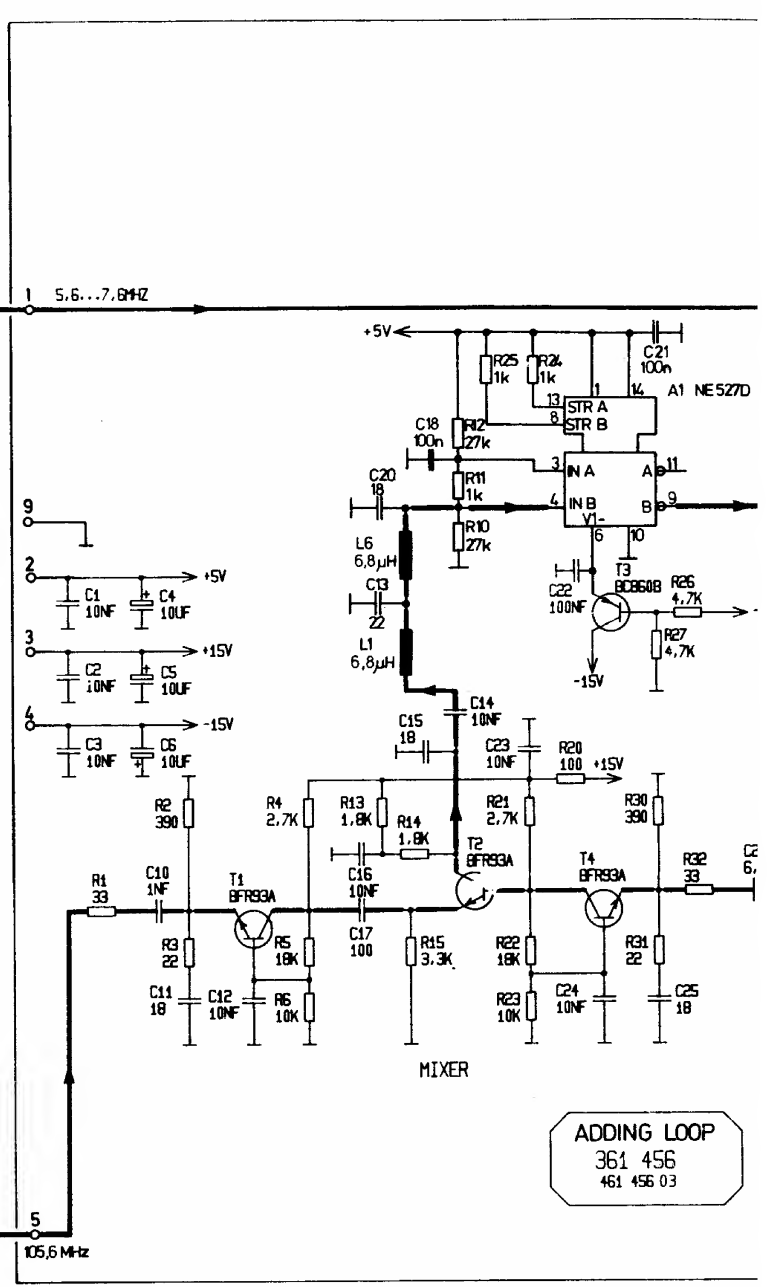
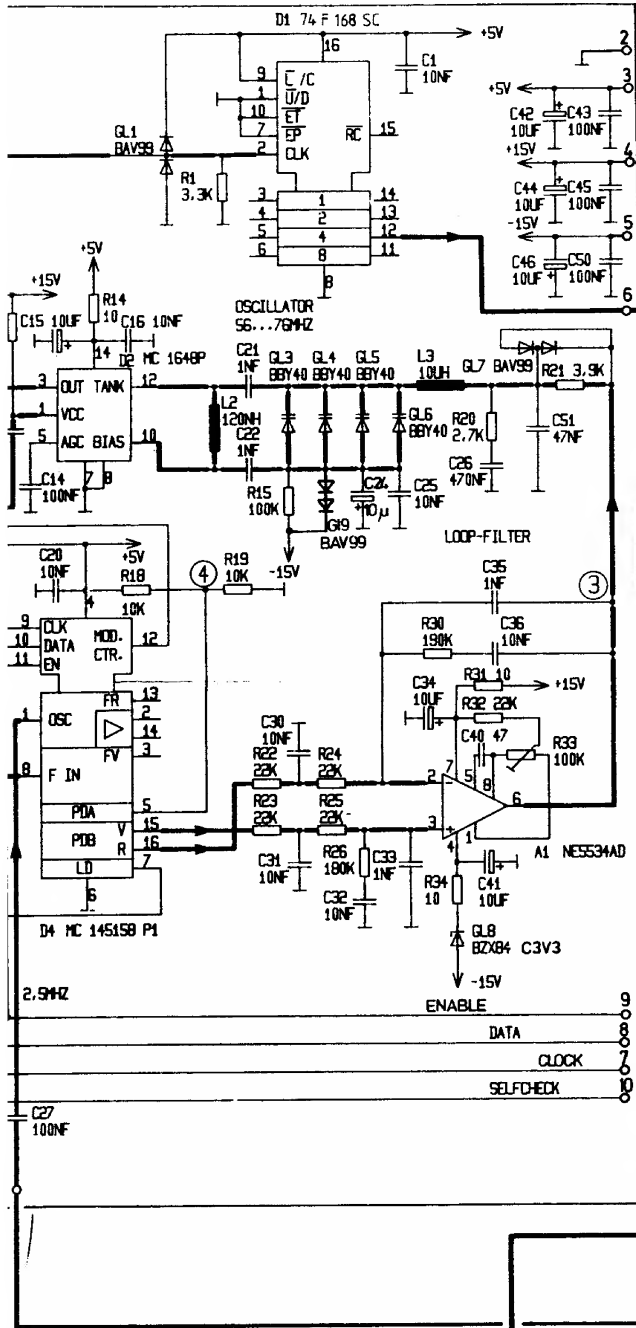

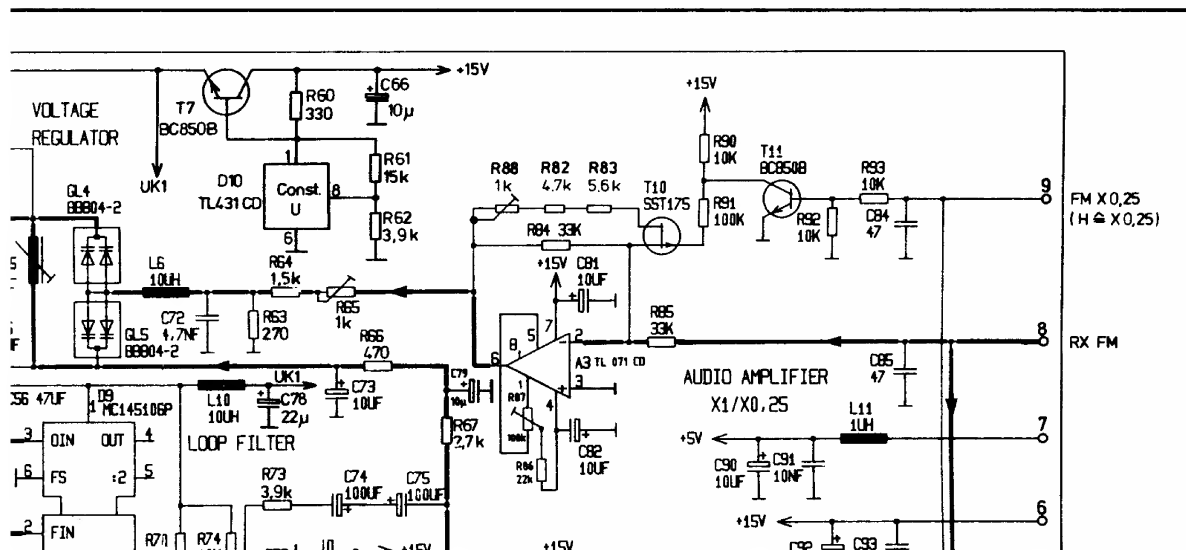
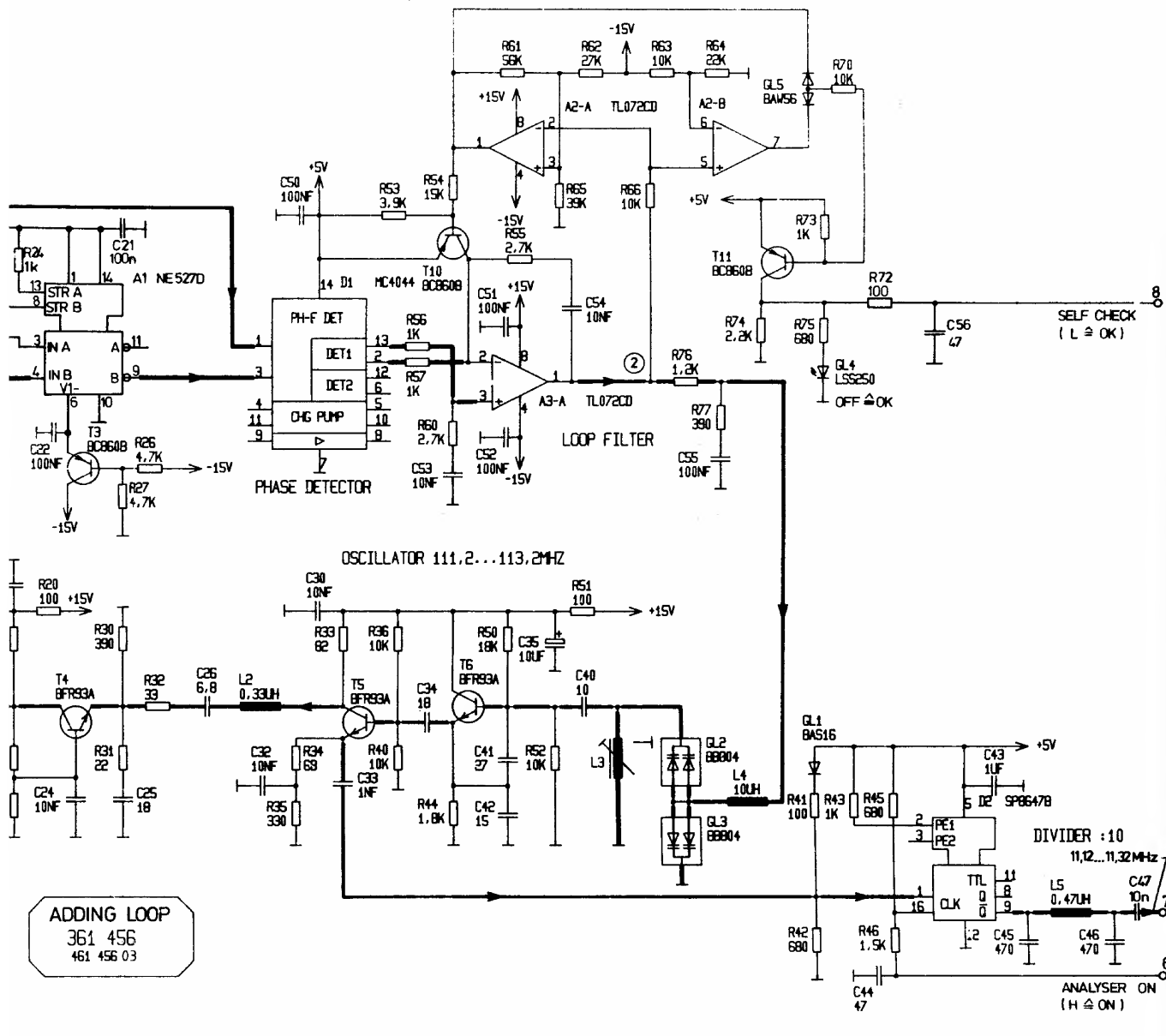

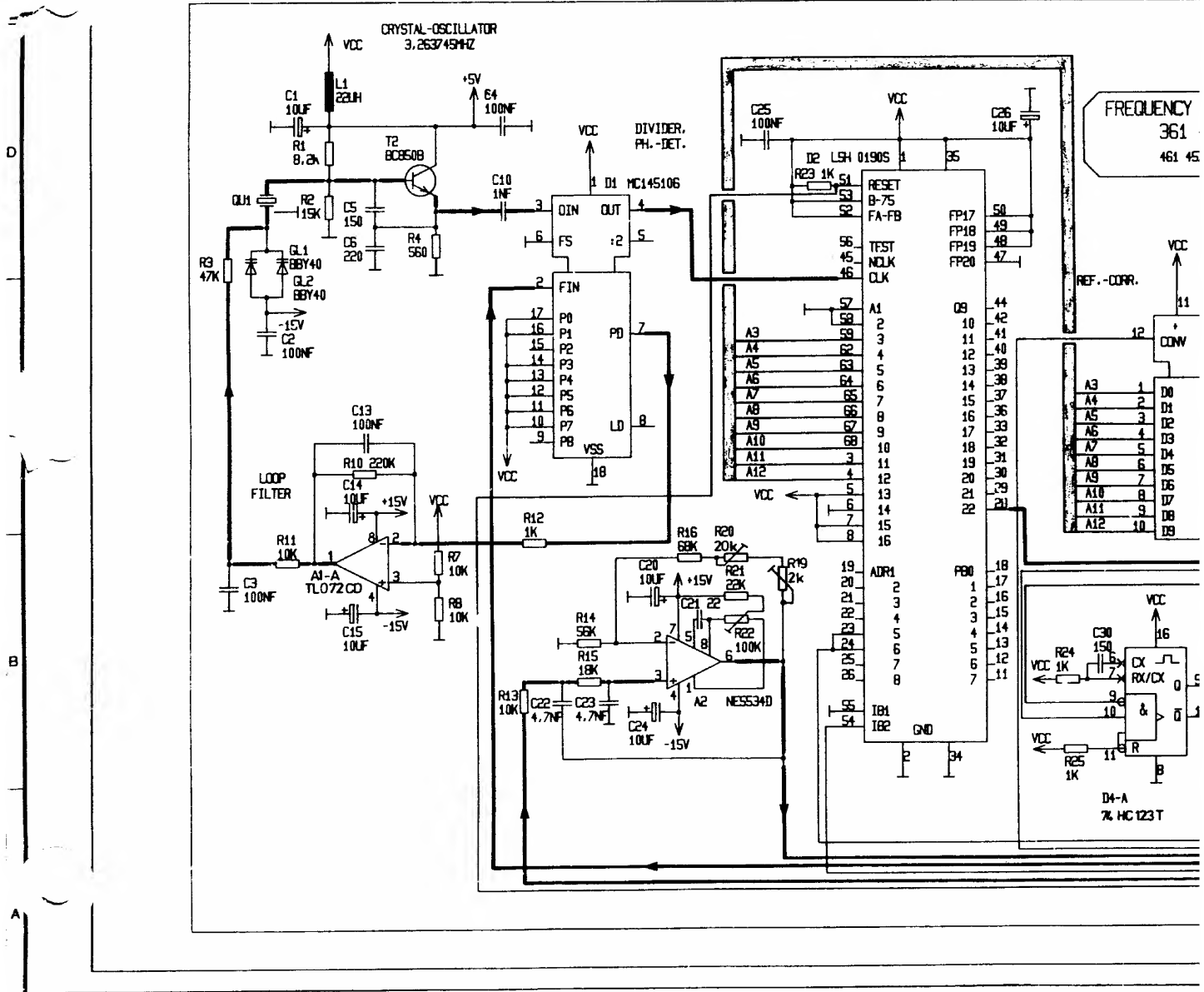
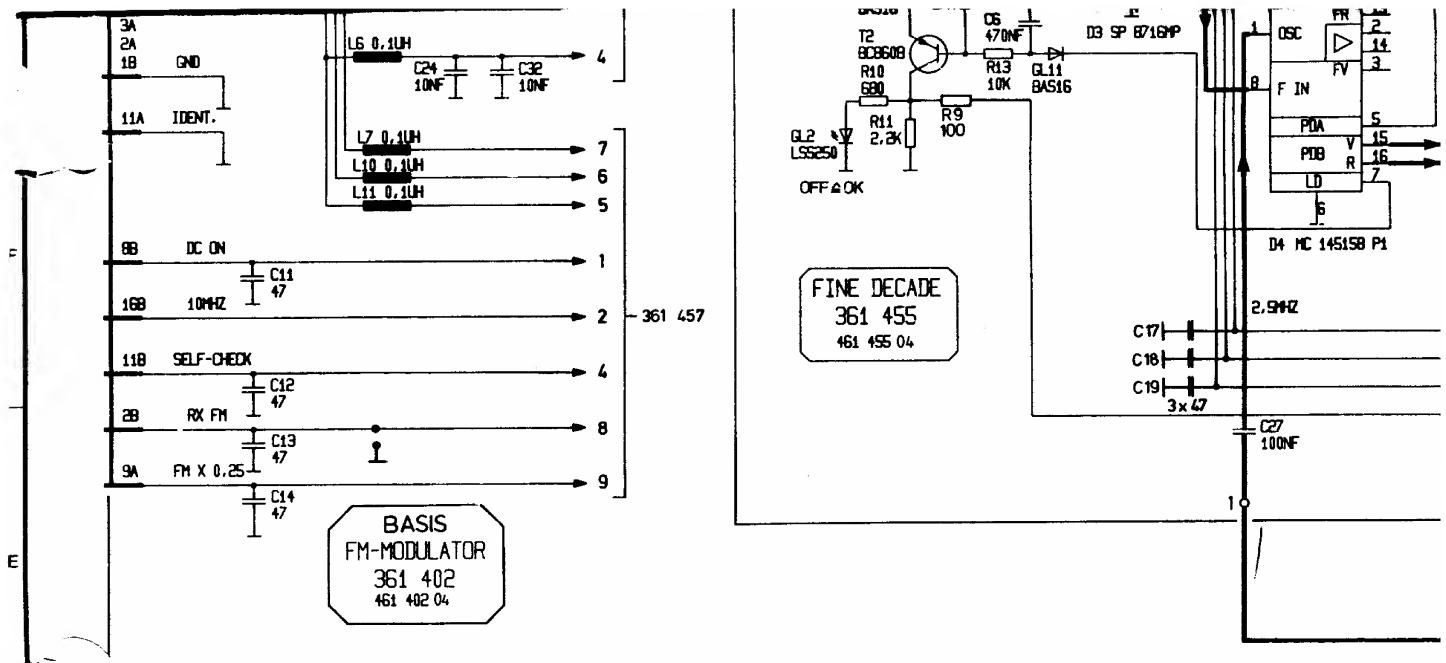

Schaltplanpositionierung ≙

13

12

11

10

9

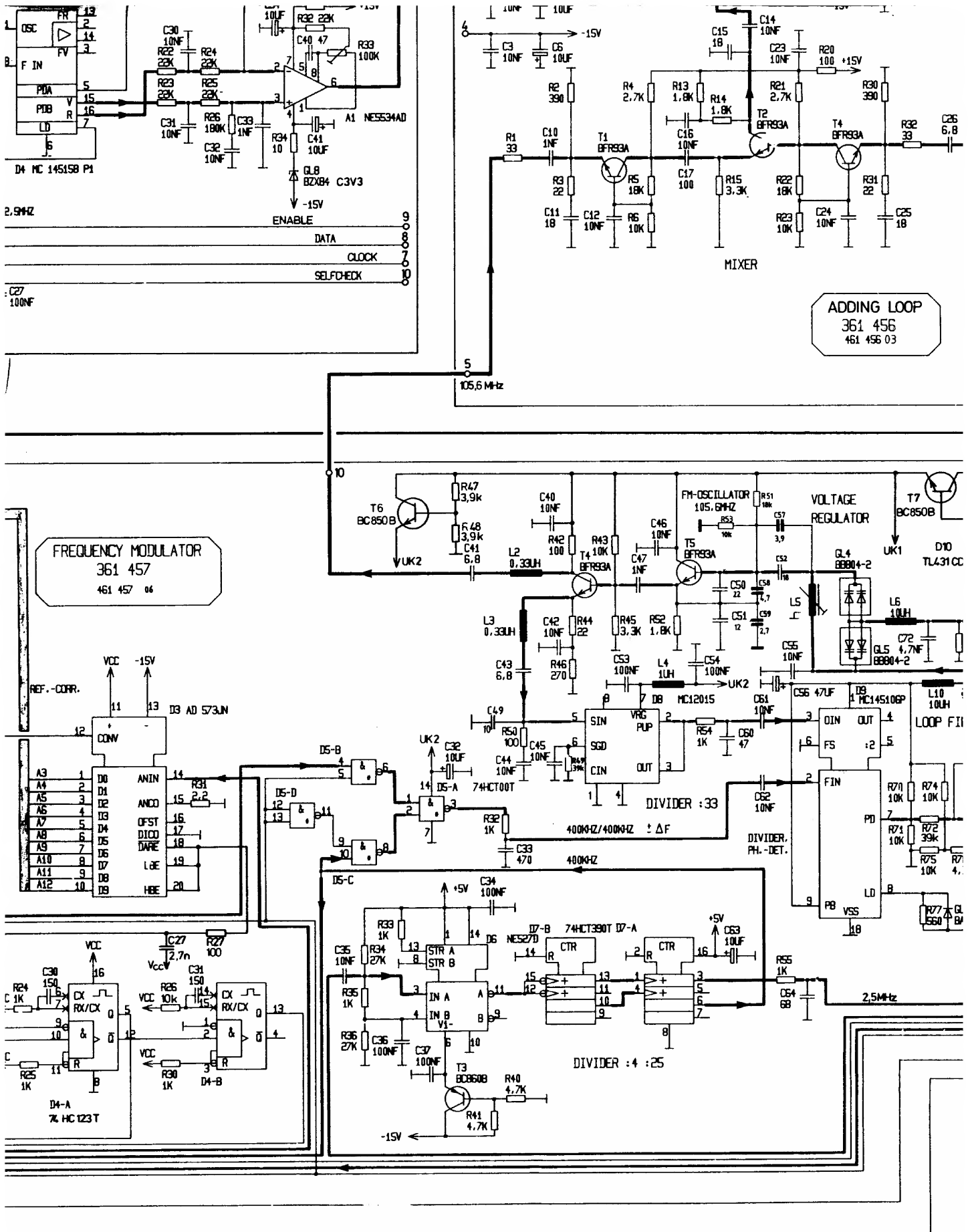

	verwendet in:		Gerät:
9	8	7	6
5			



Bauteil 835 100 16  
innerhalb 8 Std. nac

853 091

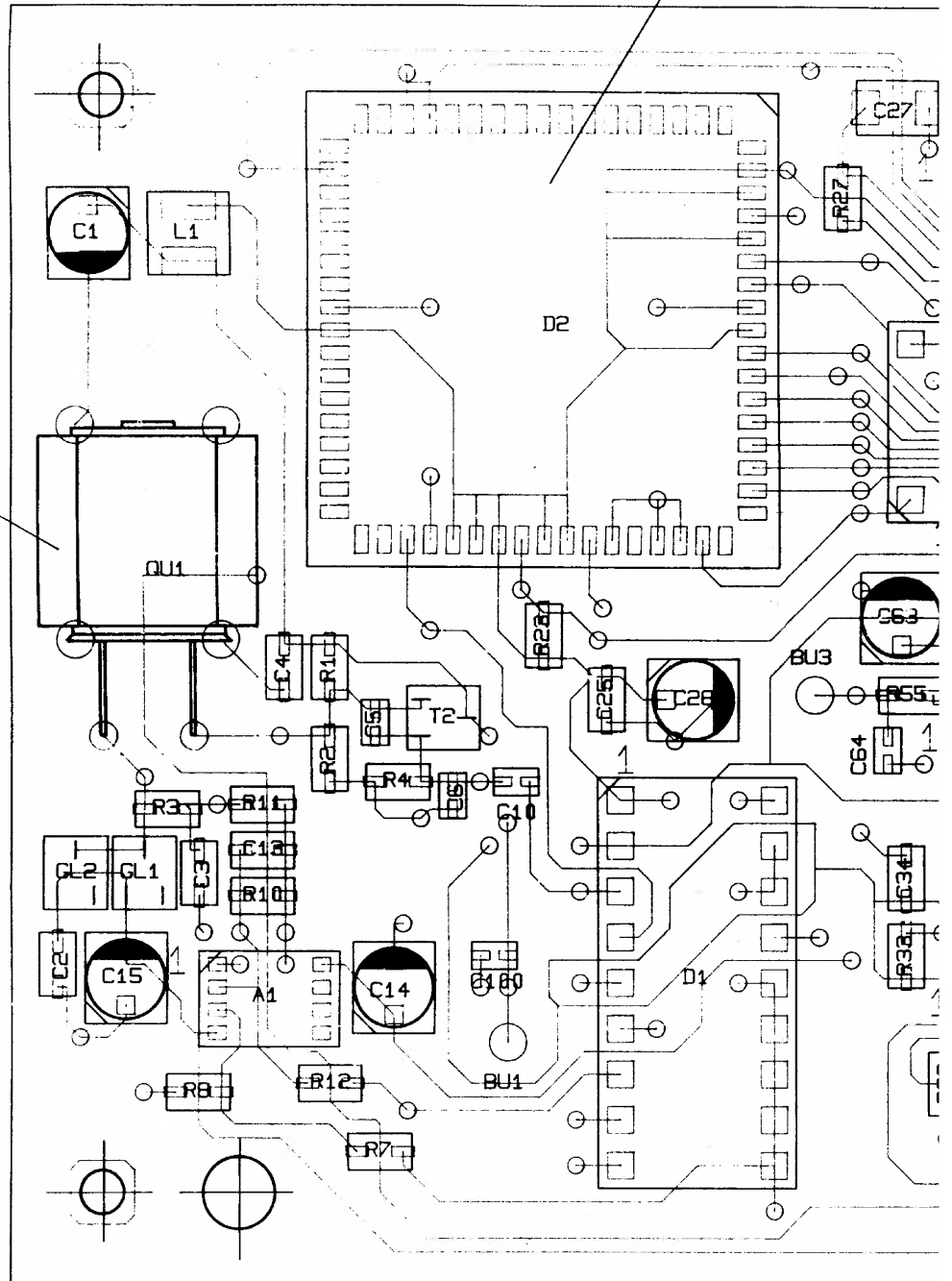



Bauteil 835 100 16 Std. bei 150°C temperr.,  
innerhalb 8 Std. nach Entnahme aus dem Ofen verarbeiten.

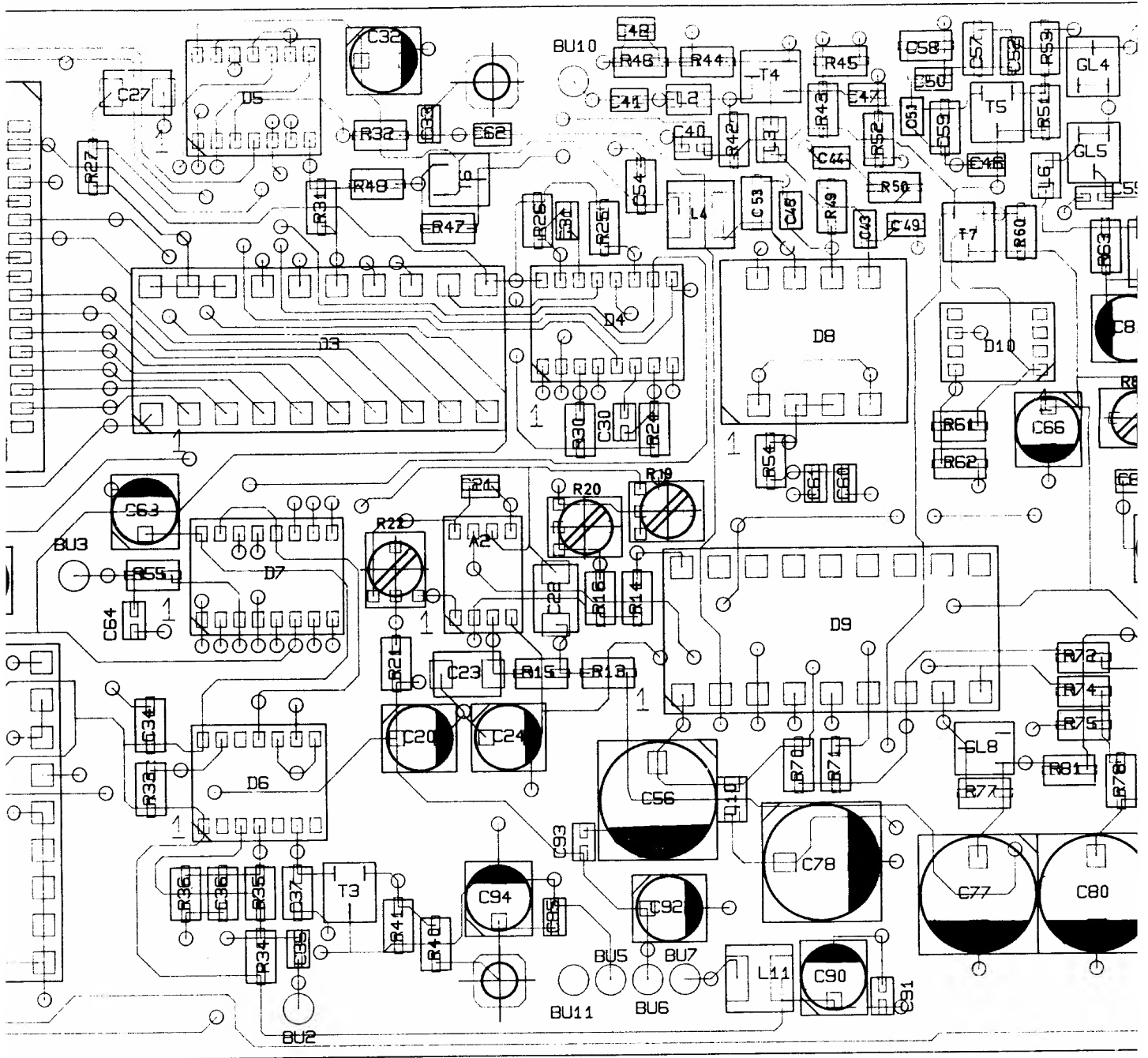

786 049 (11x)

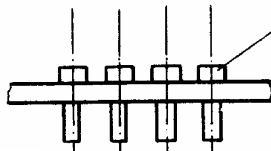

Langer Anschluß mit Isolierschlauch überzogen  
889 017 l= 5 mm

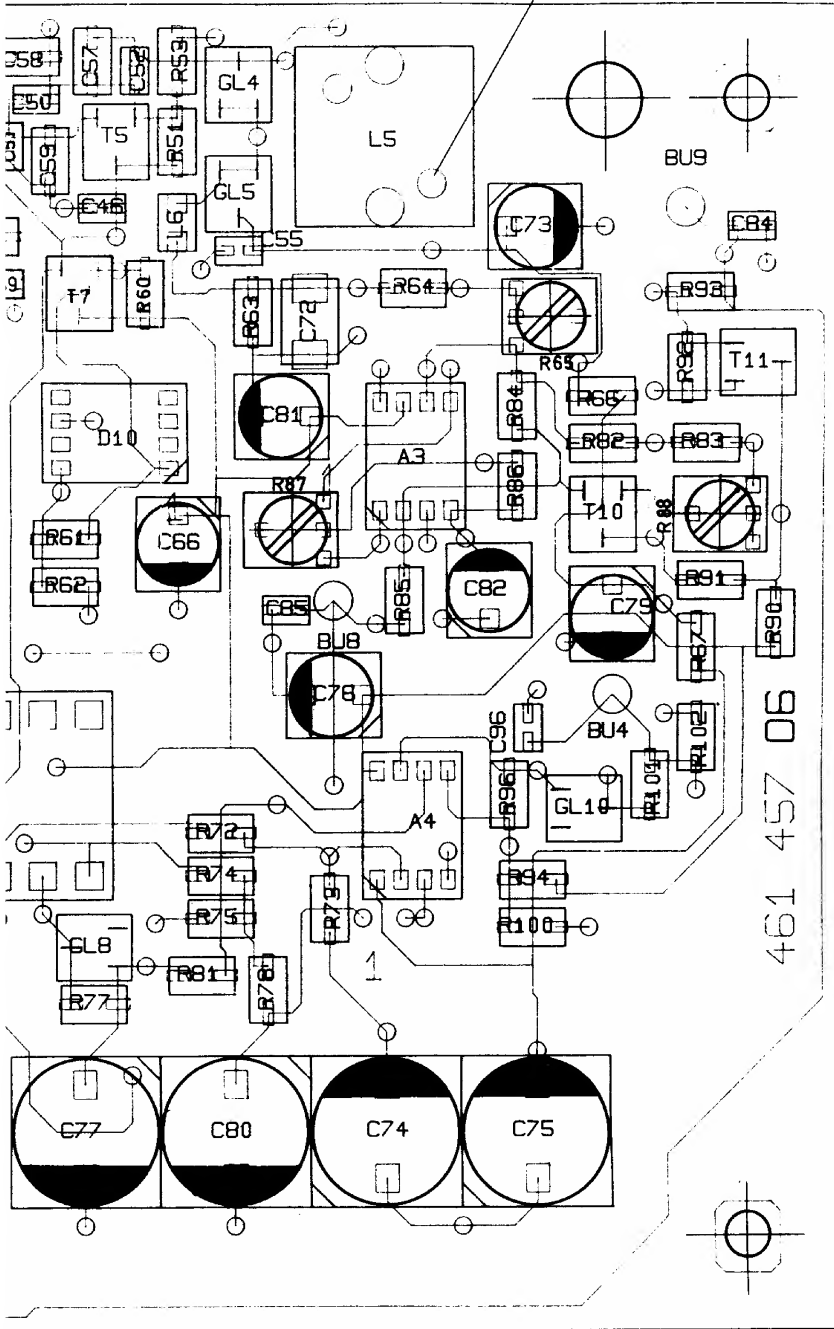



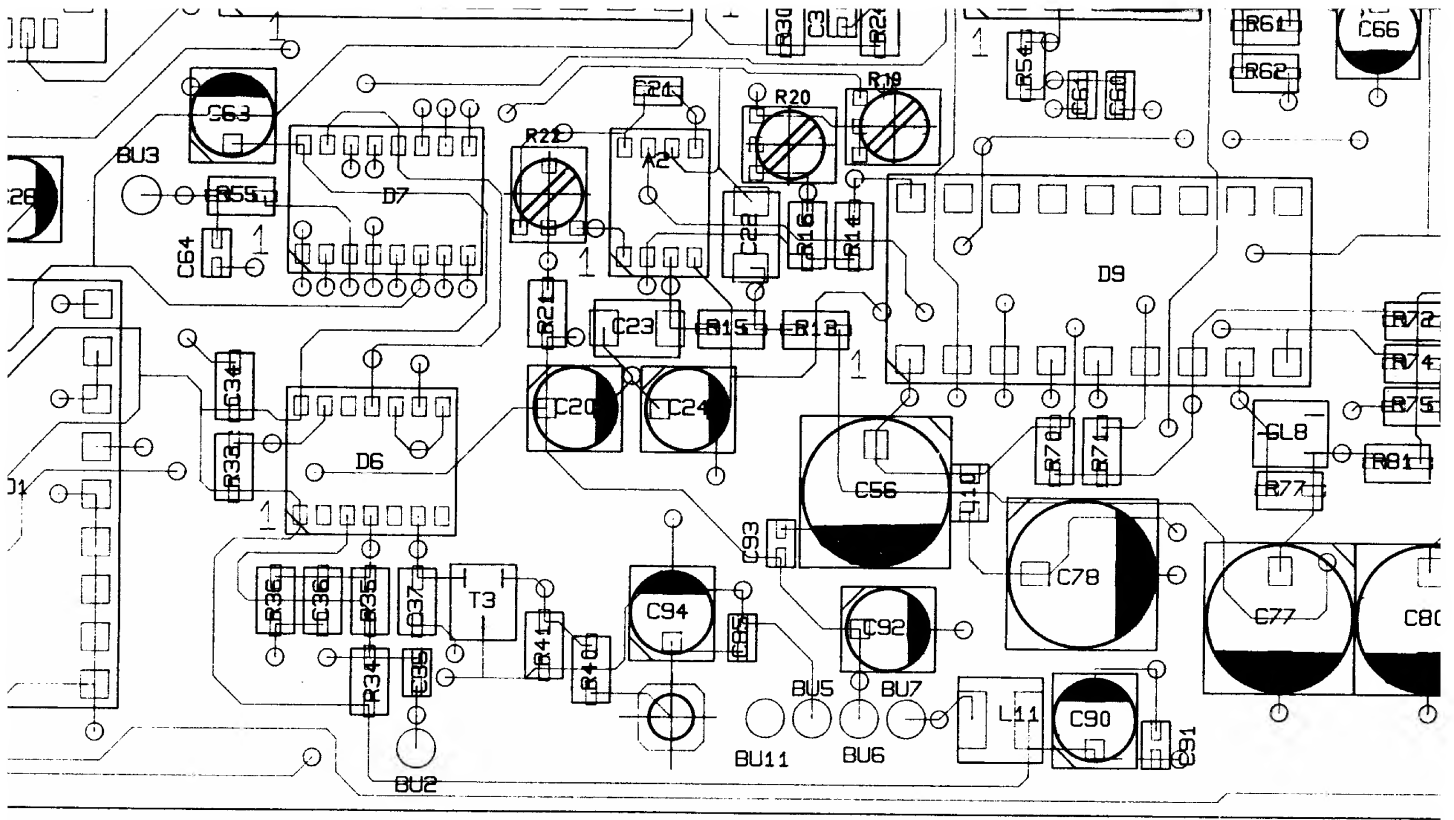

786 049 (11x)

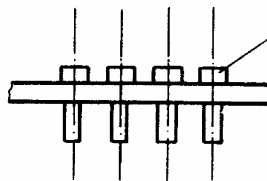

		verwendet in:			Gerät:
9	8	7	6	5	4

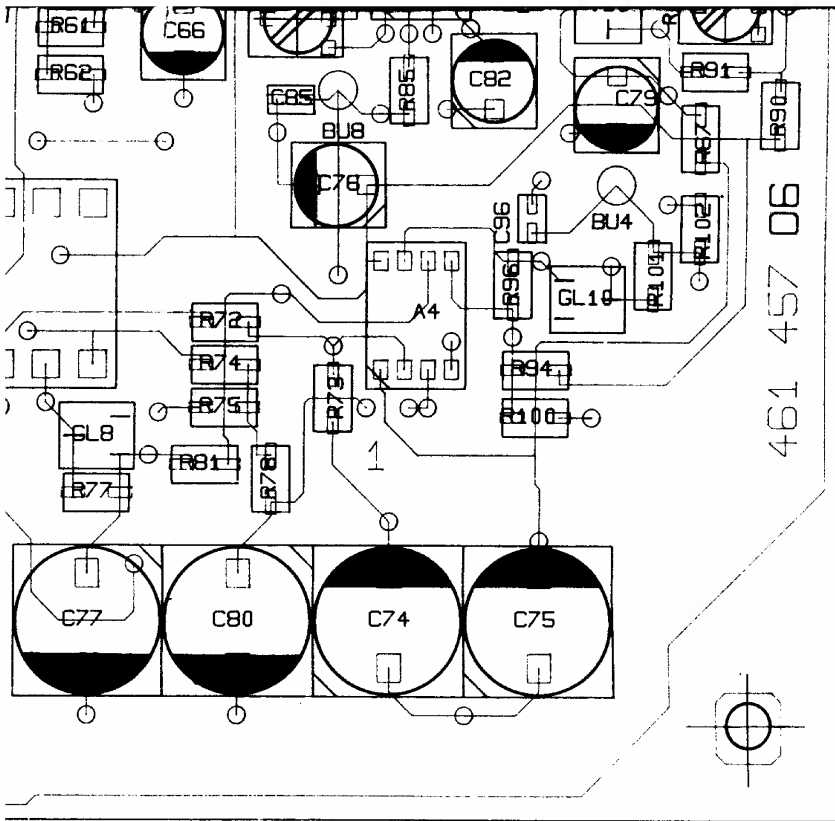

1x)

 = Kontrollmaß

10	1977.09	19.9.87	(L.V.)	Richtst.	Fremd- toleranzen	Maßstab	Schlumberger Meßgeräte GmbH Ingoledtcher Straße 67 a 8000 München 48	
09	1976.06	30.3.87	SLG	Werkstoff	±0,2	4:1		Bestückte Leiterplatte Typ: FREQUENCY DIVIDER
08	1976.02	6.0.87	ADP					
07	1966.12	28.8.67	ADP	Oberfläche	SMZ gez. 26.6	Name ADP	361 457	
11	2000.10	26.9.00	Kc	Ausgabe	best.	Gerät: 40317 217 031		

Diese Zeichnung ist unser Eigentum. Veruntreuung, unbefugte Vervielfältigung, Weitergabe an andere ist strafbar und untersagt.

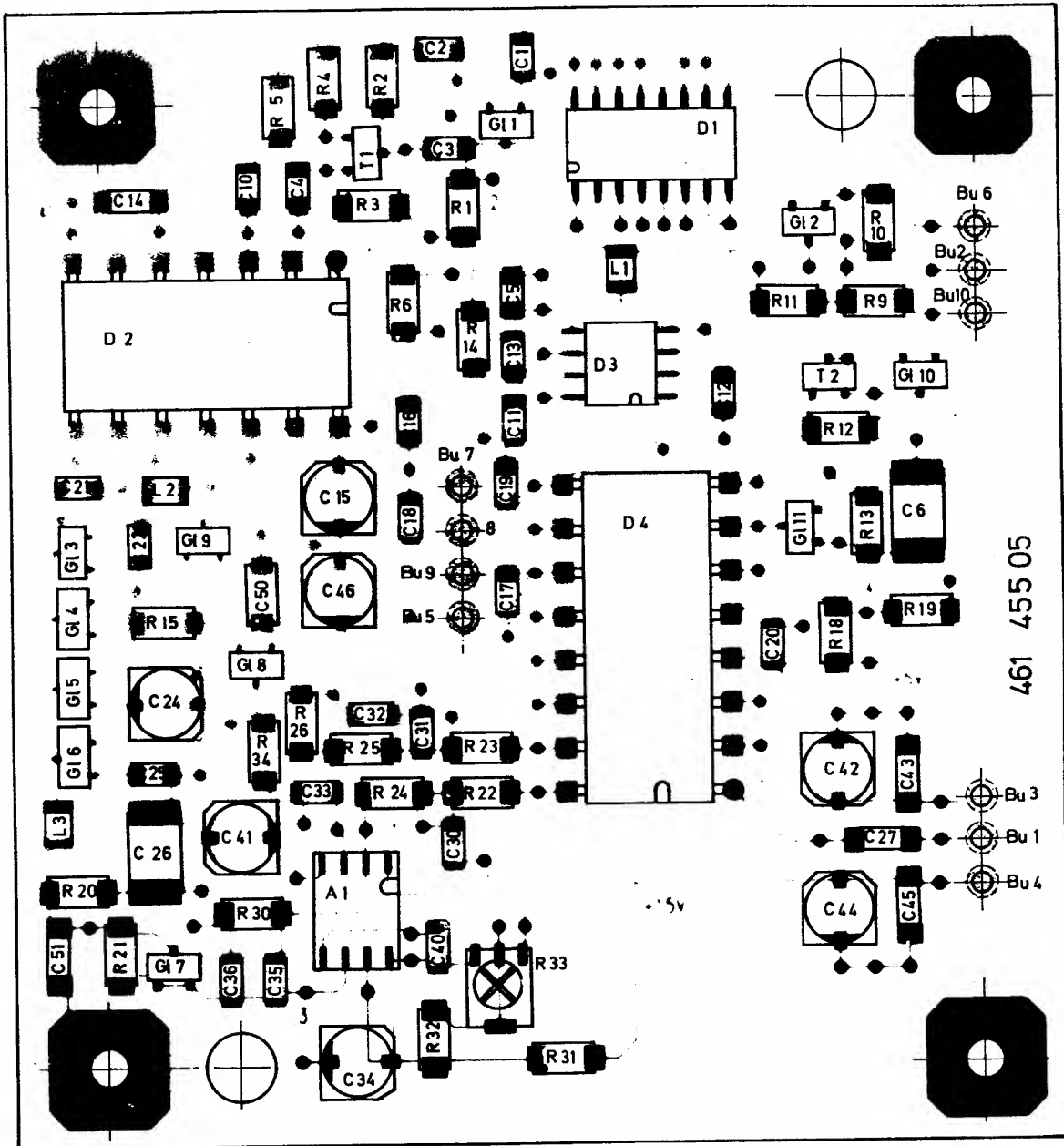

461 455 05

○ = Kontrollmaß

Ausgabe	Ändg. Memo	Datum	Name
10			
09			
08			
07			
06			
05			
04			
03			
02			
01			



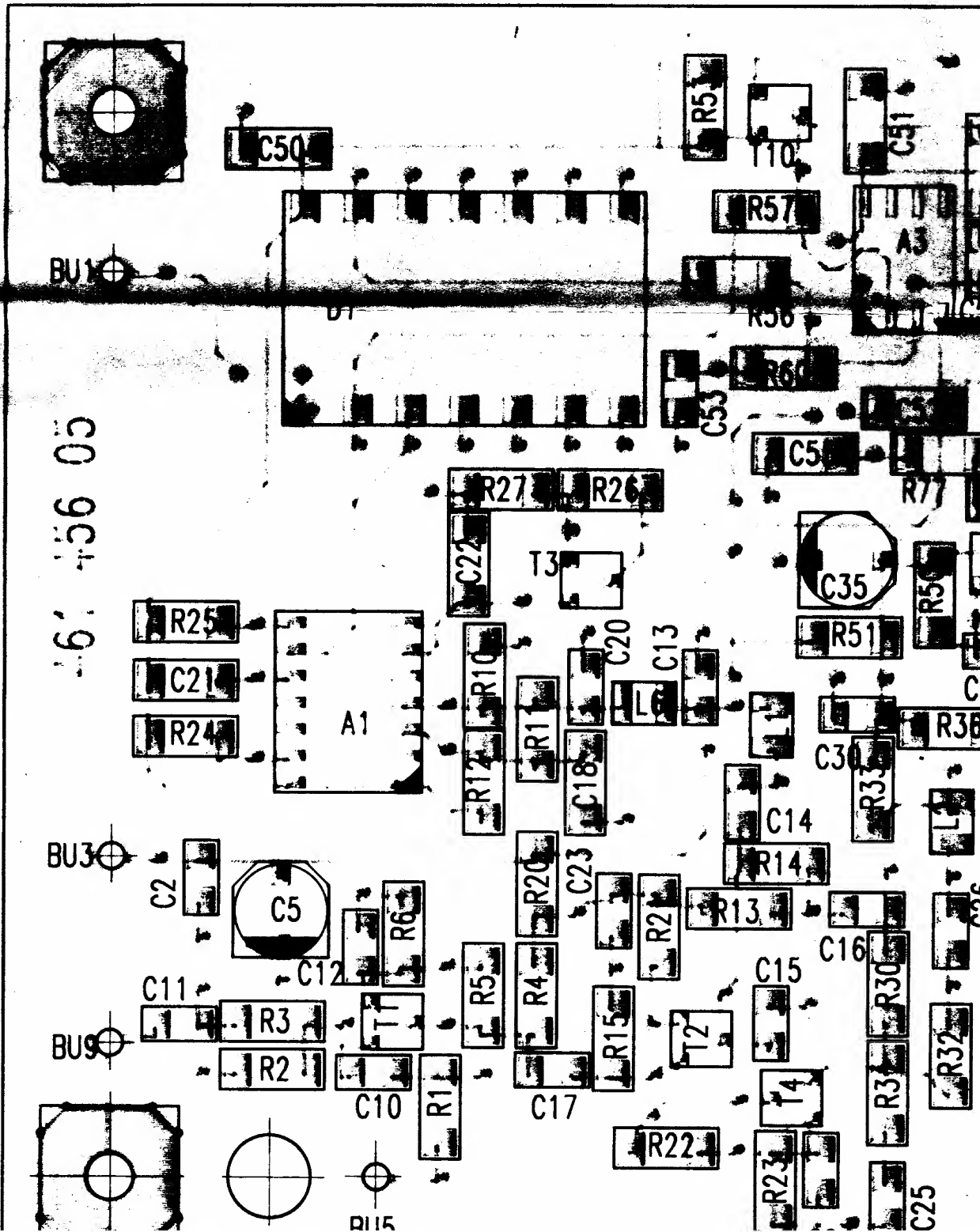



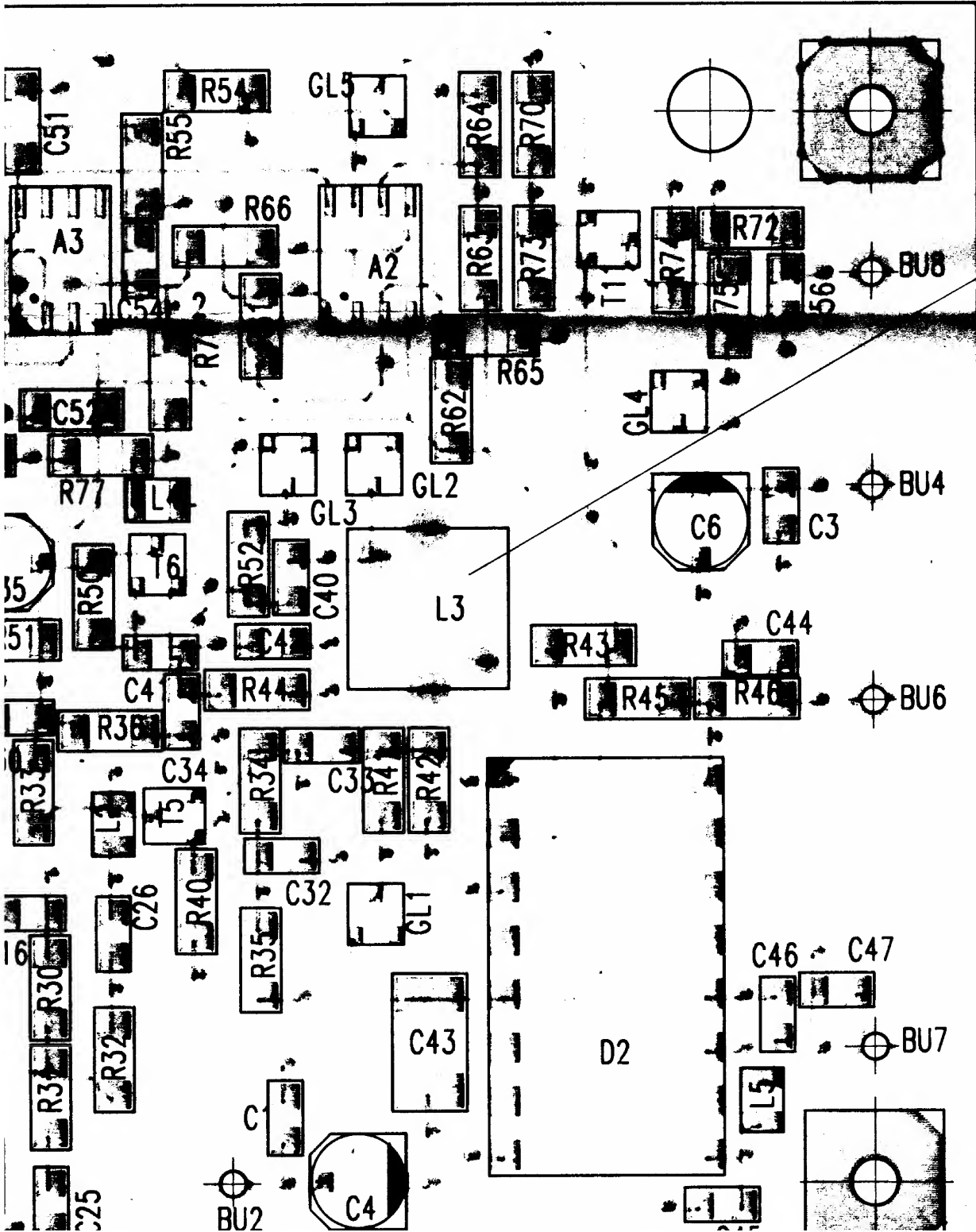

lan  
mit

3

2

1

Reflow gelötet  
Hierzu Bauteilklebmaske  
461 456 05

langer Anschluß  
mit Isolierschlauch  
889 017 überzogen  
(l=5mm)

786 049 (9x)

(L3)

max 1,5 mm

F

D

C

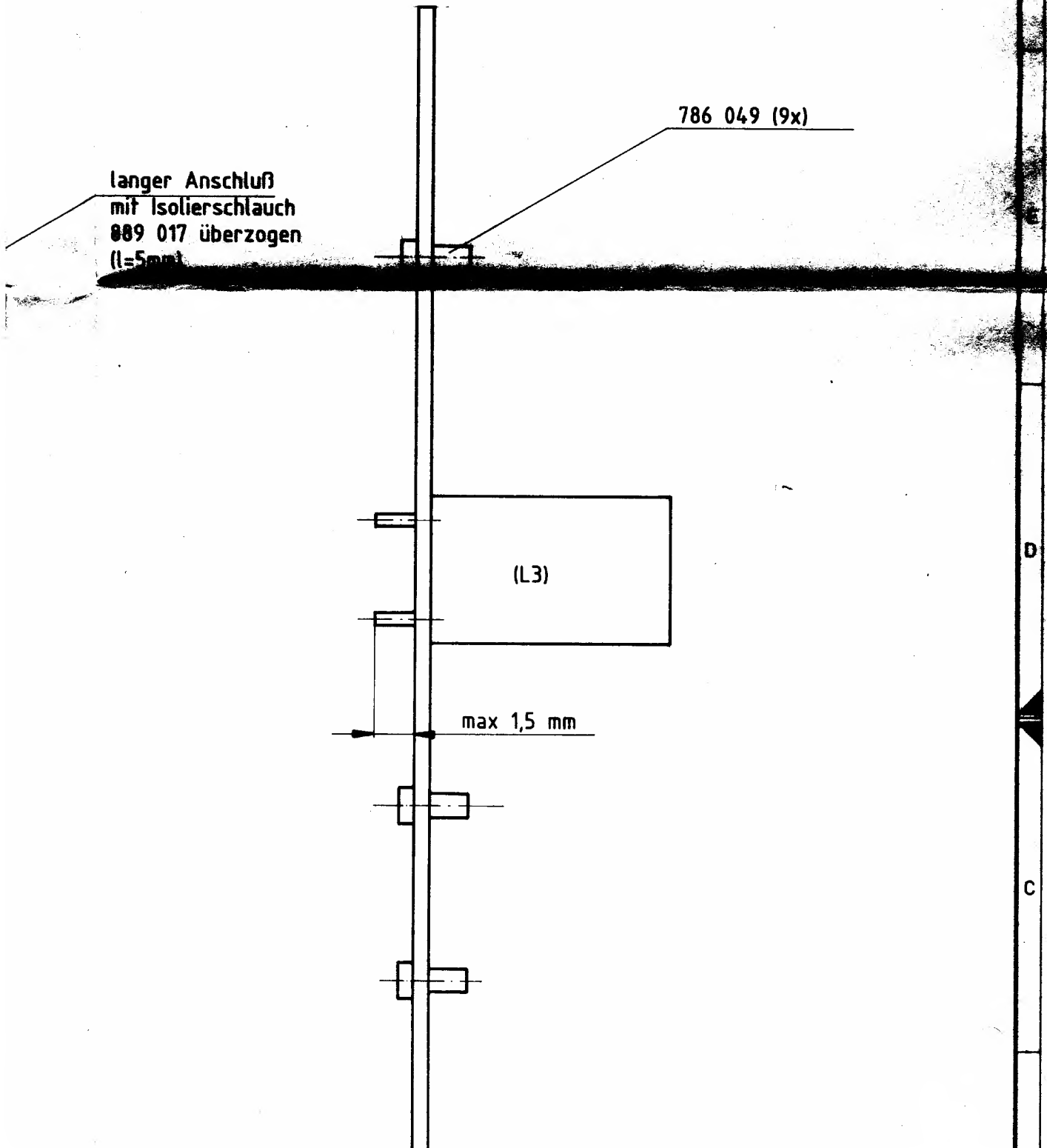

67 456 05

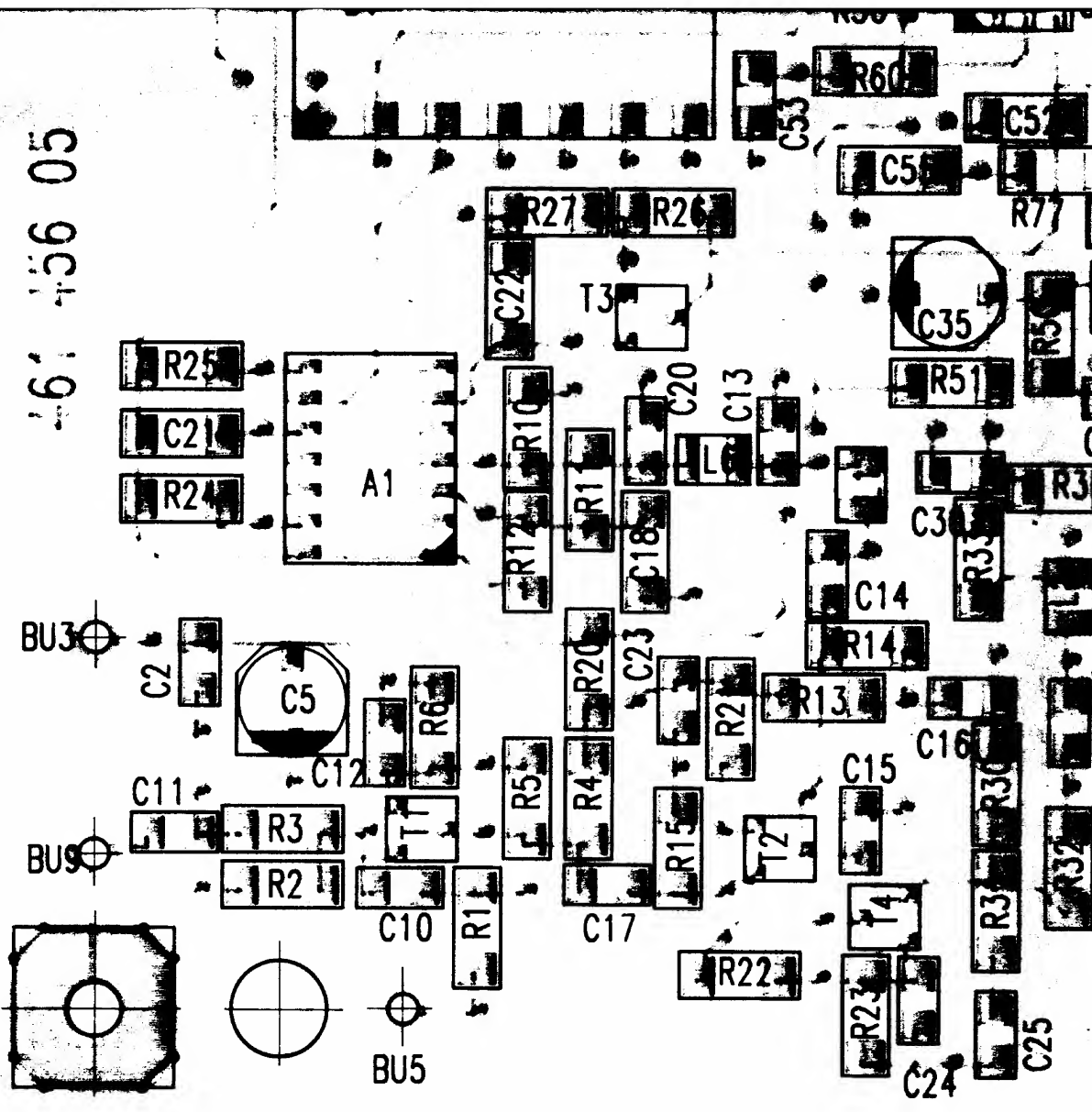

Schaltplanpositionierung  $\hat{=}$  217 031S/361 456Sa verwendet in:

8

7

6

1

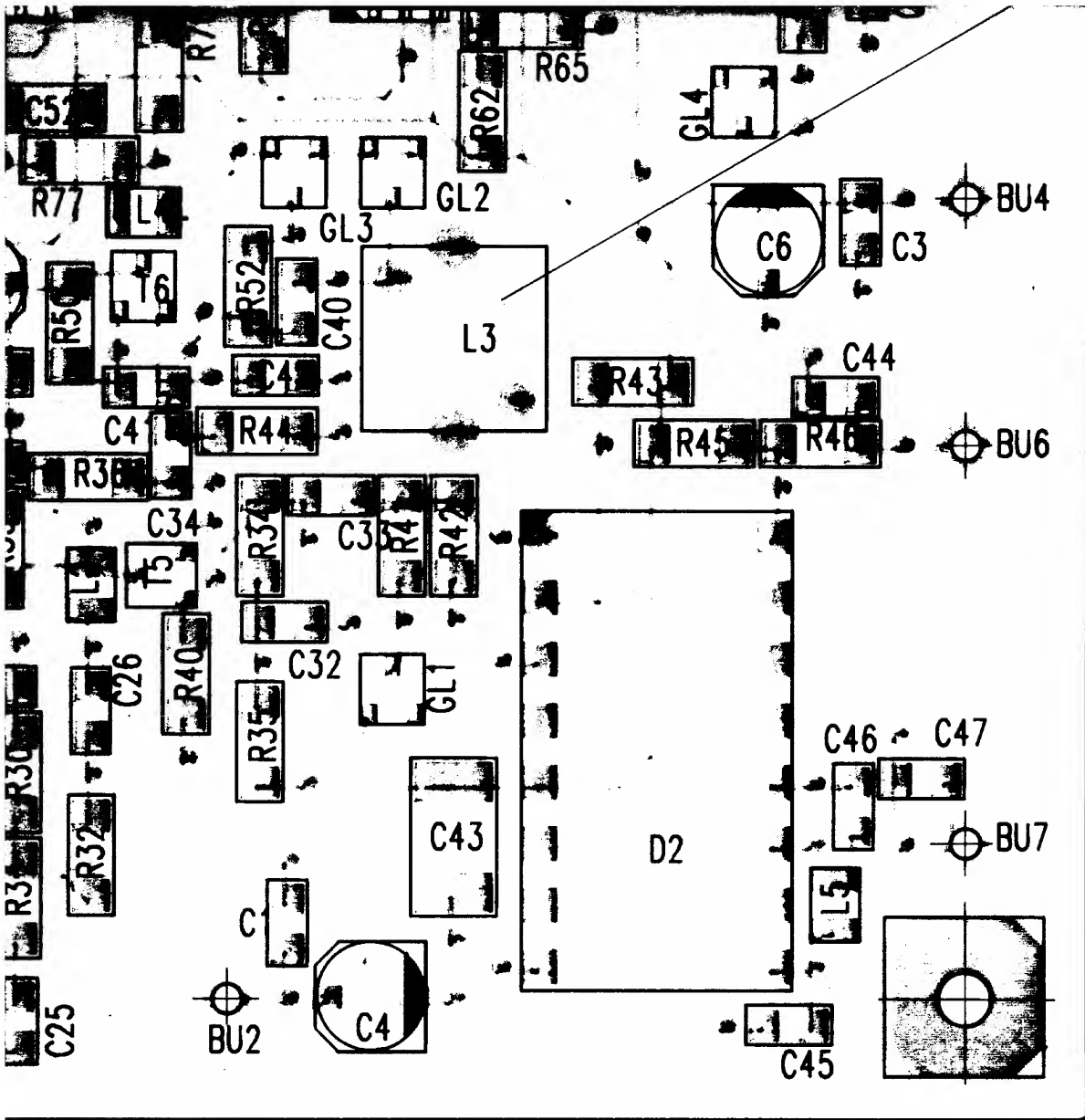

ndet in: 217 031

Gerät:

10
09
08
07
06
05
04
03
02
01

Ausgabe

Des

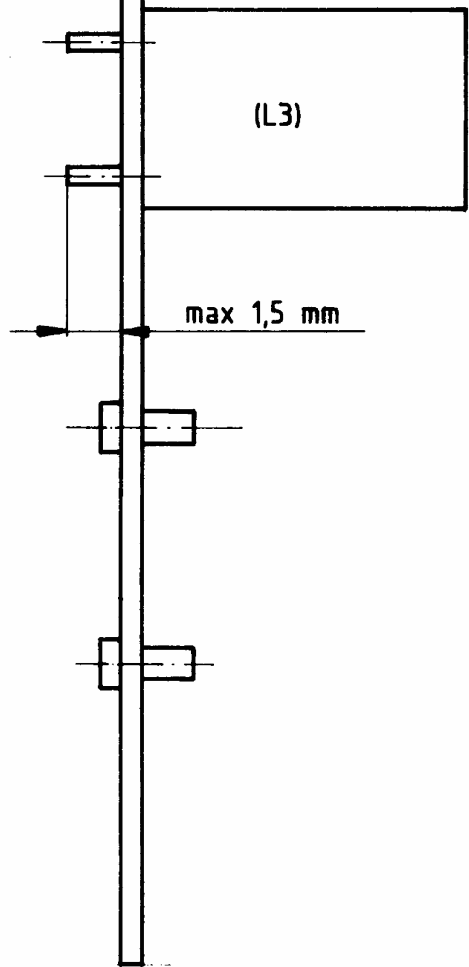

= Kontrollmaß

10				Rechtel:	Fremd- toleranzen	Meßstab	Schlumberger Meßgeräte GmbH Ingolstädter Straße 67 a 8000 München 46		
09								4:1	Bestückte Leiterplatte Typ: ADDING LOOP
08									
07									
06	8088.133	25.8.88	Staff	Werkstoff			361 456		
05									
04							Gerät: 4031/217 031		
03									
02				Oberfläche	1988	Datum	Name		
01					gez	25.8.	Staffler		
Aus- gabe	Ändg- Mittg.	Datum	Name		bearb	25.8.			
					gepr				



1	2	3	4	5	6	7	8
Pos. REF. NO.	Wert VALUE	Bezeichnung Schlumberger PART. NO.	Hersteller MANUFACT	Pos. REF. NO.	Wert VALUE	Bezeichnung Schlumberger PART. NO.	Hersteller MANUFACT
C 1	47 pF $\pm 2\%$ 63 V -	810 512	Stett				
C 2	47 pF $\pm 2\%$ 63 V -	810 512	Stett				
C 3	47 pF $\pm 2\%$ 63 V -	810 512	Stett	C 30	47 pF $\pm 2\%$ 63 V -	810 512	Stett
C 4	47 pF $\pm 2\%$ 63 V -	810 512	Stett	C 31	10 nF $\pm 10\%$ 50 V -	813 115	Stett
C 5	10 nF $\pm 10\%$ 50 V -	813 115	Stett	C 32	10 nF $\pm 10\%$ 50 V -	813 115	Stett
C 6	10 nF $\pm 10\%$ 50 V -	813 115	Stett				
C 7	10 nF $\pm 10\%$ 50 V -	813 115	Stett				
				L 1	0,1 $\mu$ H $\pm 10\%$	821 111	GOW
C 10	47 pF $\pm 2\%$ 63 V -	810 512	Stett	L 2	0,1 $\mu$ H $\pm 10\%$	821 111	GOW
C 11	47 pF $\pm 2\%$ 63 V -	810 512	Stett	L 3	0,1 $\mu$ H $\pm 10\%$	821 111	GOW
C 12	47 pF $\pm 2\%$ 63 V -	810 512	Stett	L 4	0,1 $\mu$ H $\pm 10\%$	821 111	GOW
C 13	47 pF $\pm 2\%$ 63 V -	810 512	Stett	L 5	0,1 $\mu$ H $\pm 10\%$	821 111	GOW
C 14	47 pF $\pm 2\%$ 63 V -	810 512	Stett	L 6	0,1 $\mu$ H $\pm 10\%$	821 111	GOW
C 15	100 nF $\pm 10\%$ 50 V -	813 121	Stett	L 7	0,1 $\mu$ H $\pm 10\%$	821 111	GOW
C 16	100 nF $\pm 10\%$ 50 V -	813 121	Stett				
C 17	100 nF $\pm 10\%$ 50 V -	813 121	Stett				
				L 10	0,1 $\mu$ H $\pm 10\%$	821 111	GOW
				L 11	0,1 $\mu$ H $\pm 10\%$	821 111	GOW
C 20	10 nF $\pm 10\%$ 50 V -	813 115	Stett				
C 21	10 nF $\pm 10\%$ 50 V -	813 115	Stett				
C 22	10 nF $\pm 10\%$ 50 V -	813 115	Stett	St 54		884 508	PAND
C 23	10 nF $\pm 10\%$ 50 V -	813 115	Stett				
C 24	10 nF $\pm 10\%$ 50 V -	813 115	Stett				
C 25	10 nF $\pm 10\%$ 50 V -	813 115	Stett				
C 26	10 nF $\pm 10\%$ 50 V -	813 115	Stett				
C 27	10 nF $\pm 10\%$ 50 V -	813 115	Stett				

07				Schlumberger Meßgeräte GmbH Ingolstädter Straße 67 a 8000 München 46			Schaltteilliste EL. PARTS LIST		Liste besteht LIST CONSISTS	
06										Benennung DESCRIPTION
05							Bestückte Leiterplatte Typ: Basis FM - Modulator		1	Blatt SHEETS
04							Bezeichnung Schlumberger PART NO		361 402 Sa	
03								Blatt Nr SHEET NO		
02				Tag DATE	Name NAME		1			
01				geschr	15.7.86	Münch				
	6088.18	9.9.86	29	bearb			Hierzu Schaltplan SEE CIRCUIT DIAGRAM	217 031 S		
Ausgabe ISSUE	And-Mittig Nr MODIFIC. NO	Tag DATE	Name NAME	gedr			Gerät:	4031		

1	2	3	4	5	6	7	8
Pos. REF. NO.	Wert VALUE	Bezeichnung Schlumberger PART. NO.	Hersteller MANUFACT	Pos. REF. NO.	Wert VALUE	Bezeichnung Schlumberger PART. NO.	Hersteller MANUFACT
A 1	ME 5534 AD	834 209	VAL	C 22	1 nF $\pm 10\%$ 50 V-	813 247	VAL
				C 24	10 $\mu$ F $\pm 20\%$ 16 V-	814 382	RÖD
				C 25	10 nF $\pm 10\%$ 50 V-	813 332	VAL
				C 26	470 nF $\pm 10\%$ 50 V-	813 383	VAL
				C 27	100 nF $\pm 10\%$ 50 V-	813 375	VIT
C 1	10 nF $\pm 10\%$ 50 V-	813 332	VAL				
C 2	10 nF $\pm 10\%$ 50 V-	813 332	VAL				
C 3	10 nF $\pm 10\%$ 50 V-	813 332	VAL	C 30	10 nF $\pm 10\%$ 50 V-	813 332	VAL
C 4	10 nF $\pm 10\%$ 50 V-	813 332	VAL	C 31	10 nF $\pm 10\%$ 50 V-	813 332	VAL
C 5	10 nF $\pm 10\%$ 50 V-	813 332	VAL	C 32	10 nF $\pm 10\%$ 50 V-	813 332	VAL
C 6	470 nF $\pm 10\%$ 50 V-	813 383	VAL	C 33	1 nF $\pm 10\%$ 50 V-	813 320	VAL
				C 34	10 $\mu$ F $\pm 20\%$ 16 V-	814 382	RÖD
				C 35	1 nF $\pm 10\%$ 50 V-	813 320	VAL
				C 36	10 nF $\pm 10\%$ 50 V-	813 332	VAL
C 10	10 nF $\pm 10\%$ 50 V-	813 332	VAL				
C 11	10 nF $\pm 10\%$ 50 V-	813 332	VAL				
C 12	10 nF $\pm 10\%$ 50 V-	813 332	VAL				
C 13	10 nF $\pm 10\%$ 50 V-	813 332	VAL	C 40	47 pF $\pm 5\%$ 50 V-	813 231	VAL
C 14	100 nF $\pm 10\%$ 50 V-	813 375	VAL	C 41	10 $\mu$ F $\pm 20\%$ 16 V-	814 382	RÖD
C 15	10 $\mu$ F $\pm 20\%$ 16 V-	814 382	RÖD	C 42	10 $\mu$ F $\pm 20\%$ 16 V-	814 382	RÖD
C 16	10 nF $\pm 10\%$ 50 V-	813 332	VAL	C 43	100 nF $\pm 10\%$ 50 V-	813 375	VAL
C 17	47 pF $\pm 5\%$ 50 V-	813 231	VAL	C 44	10 $\mu$ F $\pm 20\%$ 16 V-	814 382	RÖD
C 18	47 pF $\pm 5\%$ 50 V-	813 231	VAL	C 45	100 nF $\pm 10\%$ 50 V-	813 375	VAL
C 19	47 pF $\pm 5\%$ 50 V-	813 231	VAL	C 46	10 $\mu$ F $\pm 20\%$ 16 V-	814 382	RÖD
C 20	10 nF $\pm 10\%$ 50 V-	813 332	VAL				
C 21	1 nF $\pm 10\%$ 50 V-	813 247	VAL				

07				Schlumberger Meßgeräte GmbH Ingolstädter Straße 67 a 8000 München 46			Schaltteilliste EL. PARTS LIST		Liste besteht LIST CONSISTS		
06			Benennung DESCRIPTION							Bestückte Leiterplatte	
05			Typ:				FINE DECADE		Blatt SHEETS		
04											Blatt Nr. SHEET NO
03											
02				Tag DATE	Name NAME	Bezeichnung Schlumberger PART NO	361 455 Sa	1			
01	7088.125	25.8.87	Le	1986							
-	6088.18	9.9.86	Lei	geschr. 1.9.86	Dietrich	bearb. gepr.					
Ausgabe ISSUE	Änd.-Mittg. Nr. MODIFIC. NO	Tag DATE	Name NAME			Hierzu Schaltplan SEE CIRCUIT DIAGRAM	217 031 S				
							Gerät:	4031			

Diese Zeichnung ist unser Eigentum. Vervielfältigung, unbefugte Verwertung, Mitteilung an andere ist strafbar und schadenersatzpflichtig



1	2		3		4	5	6		7		8
Pos. REF. NO.	Wert VALUE		Bezeichnung Schlumberger PART. NO.		Hersteller MANUFACT	Pos. REF. NO.	Wert VALUE		Bezeichnung Schlumberger PART. NO.		Hersteller MANUFACT
						61 11	BAS 16 GEG		830 552		VAL
C 50	100 nF $\pm 10\%$ 50 V-		813 375		VAL						
C 51	47 nF $\pm 5\%$ 50 V-		813 371		VAL						
						L 1	100 nH $\pm 5\%$		821 215		STET
						L 2	120 nH $\pm 5\%$		821 216		STET
D 1	74 F 168 SC		834 470		FAI	L 3	10 $\mu$ H $\pm 10\%$		821 239		STET
D 2	MC 1648 P		834 381		NOT						
D 3	SP 8716 MP		834 447		PLES						
D 4	MC 145 158 P 1		834 408		NOT						
						R 1	3,3 k $\Omega$ $\pm 2\%$		804 743		VAL
						R 2	470 $\Omega$ $\pm 2\%$		804 733		VAL
						R 3	100 $\Omega$ $\pm 2\%$		804 725		VAL
						R 4	15 k $\Omega$ $\pm 2\%$		804 751		VAL
G1 1	BAV 99		830 491		VAL	R 5	3,9 k $\Omega$ $\pm 2\%$		804 744		VAL
G1 2	L SS 250		856 200		SIE	R 6	1 k $\Omega$ $\pm 2\%$		804 737		VAL
G1 3	BBY 40 GEG		830 619		VAL						
G1 4	BBY 40 GEG		830 619		VAL						
G1 5	BBY 40 GEG		830 619		VAL	R 9	100 $\Omega$ $\pm 2\%$		804 725		VAL
G1 6	BBY 40 GEG		830 619		VAL	R 10	680 $\Omega$ $\pm 2\%$		804 735		VAL
G1 7	BAV 99		830 491		VAL	R 11	2,2 k $\Omega$ $\pm 2\%$		804 741		VAL
G1 8	BZX 84/C 3 V 3		830 496		VAL	R 12	27 k $\Omega$ $\pm 2\%$		804 754		VAL
G1 9	BAV 99		830 491		VAL	R 13	10 k $\Omega$ $\pm 2\%$		804 749		VAL
G1 10	BAS 16 GEG		830 552		VAL	R 14	10 $\Omega$ $\pm 2\%$		804 713		VAL

07				Schlumberger Meßgeräte GmbH Ingolstädter Straße 67 a 8000 München 46			Schaltteilliste EL. PARTS LIST			Liste besteht LIST CONSISTS
06			Benennung DESCRIPTION Typ: Bestückte Leiterplatte FINE DECADE							
05							Bezeichnung Schlumberger PART. NO. 361 455 Sa			Blatt SHEETS
04			Hierzu Schaltplan SEE CIRCUIT DIAGRAM 217 031 S							
03	8088.69	25.5.88				Rödig	geschr.	1.9.86	Dietrich	Gerät: 4031
02	7088.45	2.4.87	Di	1986	Tag DATE	Name NAME				
01	6088.51	16.11.84	Lei	geschr.	1.9.86	Dietrich				
-	6088.18	9.9.86	Lei	bearb.						
Ausgabe ISSUE	Änd.-Mittig. Nr MODIFIC. NO.	Tag DATE	Name NAME	gepr.						

Diese Zeichnung ist unser Eigentum. Vervielfältigung, unbefugte Verwertung, Mitteilung an andere ist strafbar und schadenersatzpflichtig.

1	2	3	4	5	6	7	8
Pos. REF. NO.	Wert VALUE	Bezeichnung Schlumberger PART. NO.	Hersteller MANUFACT	Pos. REF. NO.	Wert VALUE	Bezeichnung Schlumberger PART. NO.	Hersteller MANUFACT
R 15	100 kΩ ± 2 %	804 761	VAL	T 1	BFR 93 A GEG	832 287	VAL
				T 2	BC 860 B GEG	832 285	VAL
R 18	10 kΩ ± 2 %	804 749	VAL				
R 19	10 kΩ ± 2 %	804 749	VAL				
R 20	2,7 kΩ ± 2 %	804 742	VAL				
R 21	3,9 kΩ ± 2 %	804 744	VAL				
R 22	22 kΩ ± 2 %	804 753	VAL				
R 23	22 kΩ ± 2 %	804 753	VAL				
R 24	22 kΩ ± 2 %	804 753	VAL				
R 25	22 kΩ ± 2 %	804 753	VAL				
R 26	180 kΩ ± 2 %	804 764	VAL				
R 30	180 kΩ ± 2 %	804 764	VAL				
R 31	10 Ω ± 2 %	804 713	VAL				
R 32	22 kΩ ± 2 %	804 753	VAL				
R 33	100 kΩ ± 25 %	807 743	BOUR				
R 34	10 Ω ± 2 %	804 713	VAL				

07						Schlumberger Meßgeräte GmbH Ingolstädter Straße 67 a 8000 München 46		Schaltteilliste EL. PARTS LIST Benennung DESCRIPTION Bestückte Leiterplatte Typ: FINE DECADE		Liste besteht LIST CONSISTS aus OF 3 Blatt SHEETS
06										
05										
04										
03										
02										
01				1986	Tag DATE	Name NAME	Bezeichnung Schlumberger PART NO	361 455 Sa	Blatt Nr. SHEET NO	3
-	6088-18	9.9.86	Lei	geschr.	1.9.86	Dietrich	Hierzu Schaltplan SEE CIRCUIT DIAGRAM	217 031 S		
Aus- gabe ISSUE	Änd.-Mittlg. Nr. MODIFIC. NO.	Tag DATE	Name NAME	bearb. gepr.		<i>Lei</i>	Gerät: 4031			

Diese Zeichnung ist unser Eigentum. Vervielfältigung, unbefugte Verwertung, Mitteilung an andere ist strafbar und schadenersatzpflichtig.

1	2		3		4	5	6		7		8
Pos. REF. NO	Wert VALUE		Bezeichnung Schlumberger PART. NO.		Hersteller MANUFACT	Pos. REF. NO.	Wert VALUE		Bezeichnung Schlumberger PART. NO.		Hersteller MANUFACT
A 1	NE 527 D		834 218		VAL	C 21	100 nF $\pm 10\%$ 50 V-		813 375		VAL
A 2	TL 072 CD		834 222		TEX	C 22	100 nF $\pm 10\%$ 50 V-		813 375		VAL
A 3	TL 072 CD		834 222		TEX	C 23	10 nF $\pm 10\%$ 50 V-		813 332		VAL
						C 24	10 nF $\pm 10\%$ 50 V-		813 332		VAL
						C 25	18 pF $\pm 5\%$ 50 V-		813 226		VAL
						C 26	6,8 pF $\pm 0,25\%$ 50 V-		813 221		VAL
C 1	10 nF $\pm 10\%$ 50 V-		813 332		VAL						
C 2	10 nF $\pm 10\%$ 50 V-		813 332		VAL						
C 3	10 nF $\pm 10\%$ 50 V-		813 332		VAL	C 30	10 nF $\pm 10\%$ 50 V-		813 332		VAL
C 4	10 $\mu$ F $\pm 20\%$ 16 V-		814 382		RÖD						
C 5	10 $\mu$ F $\pm 20\%$ 16 V-		814 382		RÖD	C 32	10 nF $\pm 10\%$ 50 V-		813 332		VAL
C 6	10 $\mu$ F $\pm 20\%$ 16 V-		814 382		RÖD	C 33	1 nF $\pm 5\%$ 50 V-		813 247		VAL
						C 34	18 pF $\pm 5\%$ 50 V-		813 226		VAL
						C 35	10 $\mu$ F $\pm 20\%$ 16 V-		814 382		RÖD
C 10	1 nF $\pm 5\%$ 50 V-		813 247		VAL						
C 11	18 pF $\pm 5\%$ 50 V-		813 226		VAL						
C 12	10 nF $\pm 10\%$ 50 V-		813 332		VAL						
C 13	22 pF $\pm 5\%$ 50 V-		813 227		VAL	C 40	10 pF $\pm 5\%$ 50 V-		813 223		VAL
C 14	10 nF $\pm 10\%$ 50 V-		813 332		VAL	C 41	27 pF $\pm 5\%$ 50 V-		813 228		VAL
C 15	18 pF $\pm 5\%$ 50 V-		813 226		VAL	C 42	15 pF $\pm 5\%$ 50 V-		813 225		VAL
C 16	10 nF $\pm 10\%$ 50 V-		813 332		VAL	C 43	1 $\mu$ F $\pm 20\%$ 50 V-		813 390		VIT
C 17	100 pF $\pm 5\%$ 50 V-		813 235		VAL	C 44	47 pF $\pm 5\%$ 50 V-		813 231		VAL
C 18	100 nF $\pm 10\%$ 50 V-		813 375		VAL	C 45	470 pF $\pm 5\%$ 50 V-		813 243		VAL
						C 46	470 pF $\pm 5\%$ 50 V-		813 243		VAL
C 20	18 pF $\pm 5\%$ 50 V-		813 226		VAL	C 47	10 nF $\pm 10\%$ 50 V-		813 332		VAL

07				Schlumberger Meßgeräte GmbH			Schaltteilliste			Liste besteht LIST CONSISTS		
06				Ingolstädter Straße 67 a			EL. PARTS LIST			aus OF 4		
05				8000 München 46			Benennung DESCRIPTION			Blatt SHEETS		
04							Bestückte Leiterplatte					
03							Typ: ADDING LOOP					
02				1986	Tag DATE	Name NAME	Bezeichnung Schlumberger PART NO		361 456 Sa		Blatt Nr SHEET NO	
01	7088.45	2.4.87	Di	geschr	2.9.86	Dietrich			217 031 S		1	
	6088.18	9.9.86	Ca	bearb			Hierzu Schaltplan SEE CIRCUIT DIAGRAM					
Aus- gabe ISSUE	Änd.-Mittg. Nr MODIFIC. NO.	Tag DATE	Name NAME	bearb gepr			Gerät:		4031			

Diese Zeichnung ist unser Eigentum. Vervielfältigung, unbefugte Verwertung, Mitteilung an andere ist strafbar und schadenersatzpflichtig

1	2	3	4	5	6	7	8
Pos. REF. NO.	Wert VALUE	Bezeichnung Schlumberger PART. NO.	Hersteller MANUFACT	Pos. REF. NO.	Wert VALUE	Bezeichnung Schlumberger PART. NO.	Hersteller MANUFACT
				L 1	6,8 $\mu$ H $\pm$ 10 %	821 237	STET
				L 2	0,33 $\mu$ H $\pm$ 5 %	821 221	STET
C 50	100 nF $\pm$ 10 % 50 V-	813 375	VAL	L 3	5,5 Windungen	821 925	NEO
C 51	100 nF $\pm$ 10 % 50 V-	813 375	VAL	L 4	10 $\mu$ H $\pm$ 10 %	821 239	STET
C 52	100 nF $\pm$ 10 % 50 V-	813 375	VAL	L 5	0,47 $\mu$ H $\pm$ 5 %	821 223	STET
C 53	10 nF $\pm$ 10 % 50 V-	813 332	VAL	L 6	6,8 $\mu$ H $\pm$ 10 %	821 237	STET
C 54	10 nF $\pm$ 10 % 50 V-	813 332	VAL				
C 55	100 nF $\pm$ 10 % 50 V-	813 375	VAL				
C 56	47 pF $\pm$ 5 % 50 V-	813 231	VAL	R 1	33 $\Omega$ $\pm$ 2 %	804 719	VAL
				R 2	390 $\Omega$ $\pm$ 2 %	804 732	VAL
				R 3	22 $\Omega$ $\pm$ 2 %	804 717	VAL
				R 4	2,7 k $\Omega$ $\pm$ 2 %	804 742	VAL
				R 5	18 k $\Omega$ $\pm$ 2 %	804 752	VAL
D 1	MC 4044	834 679	TEX	R 6	10 k $\Omega$ $\pm$ 2 %	804 749	VAL
D 2	SP 8647 B	834 401	PLES				
				R 10	27 k $\Omega$ $\pm$ 2 %	804 754	VAL
				R 11	1 k $\Omega$ $\pm$ 2 %	804 737	VAL
G1 1	BAS 16 GEG	830 552	VAL	R 12	27 k $\Omega$ $\pm$ 2 %	804 754	VAL
G1 2	BB 804-2	830 620	SIE	R 13	1,8 k $\Omega$ $\pm$ 2 %	804 740	VAL
G1 3	BB 804-2	830 620	SIE	R 14	1,8 k $\Omega$ $\pm$ 2 %	804 740	VAL
G1 4	LSS 250	856 200	SIE	R 15	3,3 k $\Omega$ $\pm$ 2 %	804 743	VAL
G1 5	BAW 56 GEG	830 550	VAL				

07				Schlumberger Meßgeräte GmbH Ingolstädter Straße 67 a 8000 München 46			Schaltteilliste EL. PARTS LIST Benennung DESCRIPTION Bestückte Leiterplatte Typ: ADDING LOOP		Liste besteht LIST CONSISTS aus OF 4 Blatt SHEETS
06									
04				1986	Tag DATE	Name NAME	Bezeichnung Schlumberger PART NO	361 456 Sa	Blatt Nr SHEET NO 2
03				02					
01	6088.56	15.11.86	Lei	01	2.9.86	Dietrich	Hierzu Schaltplan SEE CIRCUIT DIAGRAM	217 031 S	
-	6088.11	9.9.86	Lei	geschr.			Gerät:	4031	
Aus- gabe ISSUE	Änd.-Mittig Nr. MODIFIC. NO.	Tag DATE	Name NAME	bearb. gepr.					

Diese Zeichnung ist unser Eigentum. Vervielfältigung, unbefugte Verwertung, Mitteilung an andere ist strafbar und schadenersatzpflichtig.

1	2			3		4		5		6		7		8	
Pos. REF. NO.	Wert VALUE			Bezeichnung Schlumberger PART. NO.		Hersteller MANUFACT		Pos. REF. NO.	Wert VALUE			Bezeichnung Schlumberger PART. NO.		Hersteller MANUFACT	
R 20	100 Ω ± 2 %			804 725		VAL									
R 21	2,7 kΩ ± 2 %			804 742		VAL									
R 22	18 kΩ ± 2 %			804 752		VAL									
R 23	10 kΩ ± 2 %			804 749		VAL		R 50	18 kΩ ± 2 %			804 752		VAL	
R 24	1 kΩ ± 2 %			804 737		VAL		R 51	100 Ω ± 2 %			804 725		VAL	
R 25	1 kΩ ± 2 %			804 737		VAL		R 52	10 kΩ ± 2 %			804 749		VAL	
R 26	4,7 kΩ ± 2 %			804 745		VAL		R 53	3,9 kΩ ± 2 %			804 744		VAL	
R 27	4,7 kΩ ± 2 %			804 745		VAL		R 54	15 kΩ ± 2 %			804 751		VAL	
R 28								R 55	2,7 kΩ ± 2 %			804 742		VAL	
R 29								R 56	1 kΩ ± 2 %			804 737		VAL	
R 30	390 Ω ± 2 %			804 732		VAL		R 57	1 kΩ ± 2 %			804 737		VAL	
R 31	22 Ω ± 2 %			804 717		VAL									
R 32	33 Ω ± 2 %			804 719		VAL									
R 33	82 Ω ± 2 %			804 724		VAL		R 60	2,7 kΩ ± 2 %			804 742		VAL	
R 34	68 Ω ± 2 %			804 723		VAL		R 61	56 kΩ ± 2 %			804 758		VAL	
R 35	330 Ω ± 2 %			804 731		VAL		R 62	27 kΩ ± 2 %			804 754		VAL	
R 36	10 kΩ ± 2 %			804 749		VAL		R 63	10 kΩ ± 2 %			804 749		VAL	
								R 64	22 kΩ ± 2 %			804 753		VAL	
								R 65	39 kΩ ± 2 %			804 756		VAL	
								R 66	10 kΩ ± 2 %			804 749		VAL	
R 40	10 kΩ ± 2 %			804 749		VAL									
R 41	100 Ω ± 2 %			804 725		VAL									
R 42	680 Ω ± 2 %			804 735		VAL									
R 43	1 kΩ ± 2 %			804 737		VAL		R 70	10 kΩ ± 2 %			804 749		VAL	
R 44	1,8 kΩ ± 2 %			804 740		VAL									
R 45	680 Ω ± 2 %			804 735		VAL		R 72	100 Ω ± 2 %			804 725		VAL	
R 46	1,5 kΩ ± 2 %			804 739		VAL		R 73	1 kΩ ± 2 %			804 737		VAL	
07				Schlumberger Meßgeräte GmbH Ingolstädter Straße 67 a 8000 München 46				Schaltteilliste EL. PARTS LIST Benennung DESCRIPTION Bestückte Leiterplatte Typ: ADDING LOOP					Liste besteht LIST CONSISTS aus OF 4 Blatt SHEETS		
06															
05															
04															
03															
02				1986		Tag DATE		Name NAME		361 456 Sa			Blatt Nr. SHEET NO 3		
01	7088.45	2.4.87	Di	geschr	2.9.86	Dietrich		Bezeichnung Schlumberger PART NO		217 031 S					
	6088.18	9.9.86	Re	bearb				Hierzu Schaltplan SEE CIRCUIT DIAGRAM							
Ausgabe ISSUE	Nr. MODIFIC. NO	Tag DATE	Name NAME	gepr				Gerät:		4031					

Diese Zeichnung ist unser Eigentum. Vervielfältigung, unbefugte Verwertung, Mitteilung an andere ist strafbar und schadenersatzpflichtig



1	2		3		4		5		6		7		8	
Pos. REF. NO.	Wert VALUE		Bezeichnung Schlumberger PART NO.		Hersteller MANUFACT		Pos. REF. NO.	Wert VALUE		Bezeichnung Schlumberger PART NO.		Hersteller MANUFACT		
A 1	TL 072 CD		834 222		TEX		C 21	22 pF ± 5 % 50 V-		813 227		VAL		
A 2	NE 5534 AD		834 209		VAL		C 22	4,7 nF ± 5 % 50 V-		813 255		VAL		
A 3	TL 071 CD		834 227		TEX		C 23	4,7 nF ± 5 % 50 V-		813 255		VAL		
A 4	TL 072 CD		834 222		TEX		C 24	10 µF ± 20 % 16 V-		814 382		RÖD		
							C 25	100 nF ± 10 % 50 V-		813 375		VAL		
							C 26	10 µF ± 20 % 16 V-		814 382		RÖD		
							C 27	2,7 nF ± 5 % 50 V-		813 252		VAL		
C 1	10 µF ± 20 % 16 V-		814 382		RÖD									
C 2	100 nF ± 10 % 50 V-		813 375		VAL									
C 3	100 nF ± 10 % 50 V-		813 375		VAL		C 30	150 pF ± 5 % 50 V-		813 237		VAL		
C 4	100 nF ± 10 % 50 V-		813 375		VAL		C 31	150 pF ± 5 % 50 V-		813 237		VAL		
C 5	150 pF ± 5 % 50 V-		813 237		VAL		C 32	10 µF ± 20 % 16 V-		814 382		RÖD		
C 6	220 pF ± 5 % 50 V-		813 239		VAL		C 33	470 pF ± 5 % 50 V-		813 243		VAL		
							C 34	100 nF ± 10 % 50 V-		813 375		VAL		
							C 35	10 nF ± 10 % 50 V-		813 332		VAL		
							C 36	100 nF ± 10 % 50 V-		813 375		VAL		
C 10	1 nF ± 10 % 50 V-		813 320		VAL		C 37	100 nF ± 10 % 50 V-		813 375		VAL		
C 13	100 nF ± 10 % 50 V-		813 375		VAL		C 40	10 nF ± 10 % 50 V-		813 332		VAL		
C 14	10 µF ± 20 % 16 V-		814 382		RÖD		C 41	6,8 pF ± 0,25 pF 50 V-		813 221		VAL		
C 15	10 µF ± 20 % 16 V-		814 382		RÖD		C 42	10 nF ± 10 % 50 V-		813 332		VAL		
							C 43	6,8 pF ± 0,25 pF 50 V-		813 221		VAL		
							C 44	10 nF ± 10 % 50 V-		813 332		VAL		
							C 45	10 nF ± 10 % 50 V-		813 332		VAL		
							C 46	10 nF ± 10 % 50 V-		813 332		VAL		
C 20	10 µF ± 20 % 16 V-		814 382		RÖD		C 47	1 nF ± 10 % 50 V-		813 320		VAL		

07				Schlumberger Meßgeräte GmbH Ingoistädter Straße 67a 8000 München 46				Schaltteilliste EL. PARTS LIST Bestückte Leiterplatte Typ: Frequency Modulator				Liste bestehen: LIST CONSISTS	
06			Aus OF									5	
05								Blatt SHEETS		1			
04								Blatt Nr. SHEET NO		1			
03													
02	7088,66	27.5.87	Mo.	1986	Tag DATE	Name NAME	Bezeichnung Schlumberger PART. NO.		361 457 Sa				
01	7088,44	1.4.87	Di	geschw.	10.9.86	Dietrich	Hierzu Schaltplan SEE CIRCUIT DIAGRAM		217 031 S				
---	6088,18	10.9.86	Di	bearb.		<i>LD</i>	Gerät:		4031				
Ausgabe ISSUE	Änd.-Mittg. Nr. MODIFIC. NO.	Tag DATE	Name NAME	depr.									

Diese Zeichnung ist unser Eigentum. Vervielfältigung, unbefugte Verwertung, Mitteilung an andere ist strafbar und schadenersatzpflichtig.

1	2	3	4	5	6	7	8
Pos. REF. NO	Wert VALUE	Bezeichnung Schlumberger PART NO.	Hersteller MANUFACT	Pos. REF. NO	Wert VALUE	Bezeichnung Schlumberger PART NO.	Hersteller MANUFACT
				C 75	100 µF ± 20 % 16 V-	814 394	RÖD
C 49	10 pF ± 5 % 50 V-	813 223	VAL	C 76	10 µF ± 20 % 16 V-	814 382	RÖD
C 50	22 pF ± 5 % 50 V-	813 227	VAL	C 77	22 pF ± 20 % 16 V-	814 376	RÖD
C 51	12 pF ± 5 % 50 V-	813 224	VAL	C 78	22 µF ± 20 % 16 V-	814 376	RÖD
C 52	18 pF ± 5 % 50 V-	813 226	VAL	C 79	10 µF ± 20 % 16 V-	814 382	RÖD
C 53	100 nF ± 10 % 50 V-	813 375	VAL	C 80	47 pF ± 20 % 16 V-	814 386	RÖD
C 54	100 nF ± 10 % 50 V-	813 375	VAL	C 81	10 µF ± 20 % 16 V-	814 382	RÖD
C 55	10 nF ± 10 % 50 V-	813 332	VAL	C 82	10 µF ± 20 % 16 V-	814 382	RÖD
C 56	47 µF ± 20 % 16 V-	814 386	RÖD				
C 57	3,9 pF ± 0,025 pF 63 V-	810 701	STET	C 84	47 pF ± 5 % 50 V-	813 231	VAL
C 58	4,7 pF ± 0,025 pF 63 V-	810 702	STET	C 85	47 pF ± 5 % 50 V-	813 231	VAL
C 59	2,7 pF ± 0,025 pF 63 V-	810 700	STET				
C 60	47 pF ± 5 % 50 V-	813 231	VAL				
C 61	10 nF ± 10 % 50 V-	813 332	VAL				
C 62	10 nF ± 10 % 50 V-	813 332	VAL				
C 63	10 µF ± 20 % 16 V-	814 382	RÖD	C 90	10 µF ± 20 % 16 V-	814 382	RÖD
C 64	68 pF ± 5 % 50 V-	813 233	VAL	C 91	10 nF ± 10 % 50 V-	813 332	VAL
				C 92	10 µF ± 20 % 16 V-	814 382	RÖD
C 66	10 µF ± 20 % 16 V-	814 382	RÖD	C 93	10 nF ± 10 % 50 V-	813 332	VAL
				C 94	10 µF ± 20 % 16 V-	814 382	RÖD
				C 95	10 nF ± 10 % 50 V-	813 332	VAL
				C 96	47 pF ± 5 % 50 V-	813 231	VAL
C 72	4,7 nF ± 5 % 50 V-	813 255	VAL				
C 73	10 µF ± 20 % 16 V-	814 382	RÖD	C 100	47 pF ± 5 % 50 V-	813 231	VAL
C 74	100 µF ± 20 % 6,3 V-	814 394	RÖD				

07				Schlumberger Meßgeräte GmbH Ingolstädter Straße 67 a 8000 München 46			Schaltteilliste EL. PARTS LIST Bestückte Leiterplatte Typ: Frequency Modulator		Liste besteht LIST CONSISTS
06									Benennung DESCRIPTION
05								Blatt SHEETS	
04									
03	8088.41	11.3.88	Mo.						
02	7088.66	27.5.87	Mo.	1986	Tag DATE	Name NAME	Bezeichnung Schlumberger PART. NO.	361 457 Sa	Blatt Nr SHEET NO
01	7088.44	1.4.87	Di	beschr.	18.9.86	Dietrich	Hierzu Schaltplan SEE CIRCUIT DIAGRAM	217 031 S	2
00	6088.18	18.9.86	Di	gepr.			Gerät:	4031	
Ausgabe ISSUE	Änd.-Nr. MODIFIC. NO.	Tag DATE	Name NAME	gepr.					

Diese Zeichnung ist unser Eigentum. Vervielfältigung, unbefugte Verwertung, Mitteilung an andere ist strafbar und schadenersatzpflichtig.



1	2		3		4		5		6		7		8	
Pos. REF. NO	Wert VALUE		Bezeichnung Schlumberger PART. NO.		Hersteller MANUFACT		Pos. REF. NO.	Wert VALUE		Bezeichnung Schlumberger PART. NO.		Hersteller MANUFACT		
D 1	MC 145 106 P		834 448		MOT		L 1	22 $\mu$ H $\pm$ 10 %		821 318		SIE		
D 2	L 5 H 0190 S		835 100		LSI		L 2	0,33 $\mu$ H $\pm$ 5 %		821 221		STET		
D 3	AD 573 JN		834 132		ANAL		L 3	0,33 $\mu$ H $\pm$ 5 %		821 221		STET		
D 4	74 HC 123 T		834 483		VAL		L 4	1 $\mu$ H $\pm$ 15 %		821 310		SIE		
D 5	74 HCT 00T		834 430		VAL		L 5	5,5 Wdg.		821 925		NEO		
D 6	NE 527 D		834 218		VAL		L 6	10 $\mu$ H $\pm$ 10 %		821 239		STET		
D 7	PC 74 HCT 390 T		834 438		VAL									
D 8	MC 120 15 P		834 475		MOT									
D 9	MC 145 106 P		834 448		MOT									
D 10	TL 431 CD		834 247		MOT		L 10	10 $\mu$ H $\pm$ 10 %		821 239		STET		
							L 11	1 $\mu$ H $\pm$ 15 %		821 310		SIE		
G1 1	BBY 40 GEG		830 619		VAL		Qu 1	3,263745 MHz		853 063		TELEQ		
G1 2	BBY 40 GEG		830 619		VAL									
							R 1	8,2 k $\Omega$ $\pm$ 2 %		804 748		VAL		
G1 4	BB 804-2		830 620		SIE		R 2	15 k $\Omega$ $\pm$ 2 %		804 751		VAL		
G1 5	BB 804-2		830 620		SIE		R 3	47 k $\Omega$ $\pm$ 2 %		804 757		VAL		
							R 4	560 $\Omega$ $\pm$ 2 %		804 734		VAL		
G1 8	BAS 16 GEG		830 552		VAL									
							R 7	10 k $\Omega$ $\pm$ 2 %		804 749		VAL		
G1 10	LSS 250		856 200		SIE		R 8	10 k $\Omega$ $\pm$ 2 %		804 749		VAL		
							R 10	220 k $\Omega$ $\pm$ 2 %		804 765		VAL		
							R 11	10 k $\Omega$ $\pm$ 2 %		804 749		VAL		
							R 12	1 k $\Omega$ $\pm$ 2 %		804 737		VAL		
07							<b>Schaltteilliste</b> EL. PARTS LIST Beschreibung DESCRIPTION <b>Bestückte Leiterplatte</b> Typ: <b>Frequency Modulator</b>					Liste besteht LIST CONSISTS		
08												aus OF <b>5</b>		
05							Bezeichnung Schlumberger PART. NO. <b>361 457 Sa</b>					Blatt SHEETS		
04												Blatt Nr SHEET NO		
03							Bezeichnung Schlumberger PART. NO. <b>217 031 S</b>					Blatt Nr SHEET NO		
02												Blatt Nr SHEET NO <b>3</b>		
01							Hierzu Schaltplan SEE CIRCUIT DIAGRAM <b>4031</b>							
00														
Ausgabe ISSUE	Änd.-Mittg. Nr MODIFIC. NO	Tag DATE	Name NAME	gezeichnet bearb. gepr.	Tag DATE	Name NAME								

Diese Zeichnung ist unser Eigentum. Vervielfältigung, unbefugte Verwertung, Mitteilung an andere ist strafbar und schadenersatzpflichtig.

1	2		3		4		5		6		7		8	
Pos. REF. NO	Wert VALUE		Bezeichnung Schlumberger PART. NO.		Hersteller MANUFACT		Pos. REF. NO	Wert VALUE		Bezeichnung Schlumberger PART NO		Hersteller MANUFACT		
R 13	10 kΩ ± 2 %		804 749		VAL		R 40	4,7 kΩ ± 2 %		804 745		VAL		
R 14	56 kΩ ± 2 %		804 758		VAL		R 41	4,7 kΩ ± 2 %		804 745		VAL		
R 15	18 kΩ ± 2 %		804 752		VAL		R 42	100 Ω ± 2 %		804 725		VAL		
R 16	68 kΩ ± 2 %		804 759		VAL		R 43	10 kΩ ± 2 %		804 749		VAL		
							R 44	22 Ω ± 2 %		804 717		VAL		
							R 45	3,3 kΩ ± 2 %		804 743		VAL		
R 19	2 kΩ ± 25 %		807 738		BOUR		R 46	270 Ω ± 2 %		804 730		VAL		
R 20	20 kΩ ± 25 %		807 741		BOUR		R 47	3,9 kΩ ± 2 %		804 744		VAL		
R 21	22 kΩ ± 2 %		804 753		VAL		R 48	3,9 kΩ ± 2 %		804 710		VAL		
R 22	100 kΩ ± 25 %		807 743		BOUR		R 49	39 kΩ ± 2 %		804 756		VAL		
R 23	1 kΩ ± 2 %		804 737		VAL		R 50	100 Ω ± 2 %		804 725		VAL		
R 24	1 kΩ ± 2 %		804 737		VAL		R 51	18 kΩ ± 2 %		804 752		VAL		
R 25	1 kΩ ± 2 %		804 737		VAL		R 52	1,8 kΩ ± 2 %		804 740		VAL		
R 26	10 kΩ ± 2 %		804 749		VAL		R 53	10 kΩ ± 2 %		804 749		VAL		
R 27	100 Ω ± 2 %		804 725		VAL		R 54	1 kΩ ± 2 %		804 737		VAL		
							R 55	1 kΩ ± 2 %		804 737		VAL		
R 30	1 kΩ ± 2 %		804 737		VAL									
R 31	2,2 Ω ± 2 %		804 705		VAL									
R 32	1 kΩ ± 2 %		804 737		VAL									
R 33	1 kΩ ± 2 %		804 737		VAL		R 60	330 Ω ± 2 %		804 731		VAL		
R 34	27 kΩ ± 2 %		804 754		VAL		R 61	15 kΩ ± 2 %		804 751		VAL		
R 35	1 kΩ ± 2 %		804 737		VAL		R 62	3,9 kΩ ± 2 %		804 744		VAL		
R 36	27 kΩ ± 2 %		804 754		VAL		R 63	270 Ω ± 2 %		804 730		VAL		
							R 64	1,5 kΩ ± 2 %		804 739		VAL		
							R 65	1 kΩ ± 2 %		807 737		BOUR		
							R 66	470 Ω ± 2 %		804 733		VAL		

07				Schlumberger Meßgeräte GmbH			Schaltteilliste EL. PARTS LIST				Liste besteht LIST CONSISTS	
06	8088.41	11.3.88	Mo.	Ingolstädter Straße 67 a 8000 München 46							Benennung DESCRIPTION	
04	8088.21	10.2.88	Mo.								Blatt SHEETS	
09	7088.91	16.7.87	Di									
02	7088.56	30.4.87	Di									
01	7088.44	1.4.87	Di	1986	Tag DATE	Name NAME	Bezeichnung Schlumberger PART. NO.		361 457 Sa		Blatt Nr SHEET NO	
---	6088.18	10.9.86	Di	gesch.	10.9.86	Dietrich			217 031 S			
Aus- gabe ISSUE	Änd.-Mitgl. Nr MODIFIC. NO.	Tag DATE	Name NAME	bearb. gepr.		<i>[Signature]</i>	Hierzu Schaltplan SEE CIRCUIT DIAGRAM		217 031 S		4	
							Gerät:		4031			

Diese Zeichnung ist unser Eigentum. Vervielfältigung, unbefugte Verwertung, Mitteilung an andere ist strafbar und schadenersatzpflichtig.

1	2	3	4	5	6	7	8
Pos. REF. NO.	Wert VALUE	Bezeichnung Schlumberger PART NO.	Hersteller MANUFACT	Pos. REF. NO.	Wert VALUE	Bezeichnung Schlumberger PART NO.	Hersteller MANUFACT
R 67	2,7 kΩ ± 2 %	804 742	VAL	R 94	10 kΩ ± 2 %	804 749	VAL
				R 96	470 kΩ ± 2 %	804 769	VAL
R 70	10 kΩ ± 2 %	804 749	VAL				
R 71	10 kΩ ± 2 %	804 749	VAL				
R 72	39 kΩ ± 2 %	804 756	VAL				
R 73	3,9 kΩ ± 2 %	804 744	VAL	R 100	22 kΩ ± 2 %	804 799	VAL
R 74	10 kΩ ± 2 %	804 749	VAL	R 101	2,2 kΩ ± 2 %	804 741	VAL
R 75	10 kΩ ± 2 %	804 749	VAL	R 102	1 kΩ ± 2 %	804 737	VAL
R 77	560 Ω ± 2 %	804 734	VAL				
R 78	4,7 kΩ ± 2 %	804 745	VAL				
				T 2	BC 850 B	832 284	VAL
				T 3	BC 860 B	832 285	VAL
R 81	1 kΩ ± 2 %	804 737	VAL	T 4	BFR 93 A	832 287	VAL
R 82	4,7 kΩ ± 2 %	804 745	VAL	T 5	BFR 93 A	832 287	VAL
R 83	5,6 kΩ ± 2 %	804 746	VAL	T 6	BC 850 B	832 284	VAL
R 84	33 kΩ ± 2 %	804 755	VAL	T 7	BC 850 B	832 284	VAL
R 85	33 kΩ ± 2 %	804 755	VAL				
R 86	22 kΩ ± 2 %	804 753	VAL				
R 87	100 kΩ ± 25 %	807 743	BOUR	T 10	SST 175	832 288	SILI
R 88	1 kΩ ± 25 %	807 737	BOUR	T 11	BC 850 B	832 284	VAL
R 90	10 kΩ ± 2 %	804 749	VAL				
R 91	100 kΩ ± 2 %	804 761	VAL				
R 92	10 kΩ ± 2 %	804 749	VAL				
R 93	10 kΩ ± 2 %	804 749	VAL				

07				Schlumberger Meßgeräte GmbH Ingoistädter Straße 87 a 8000 München 46				Schaltteilliste EL. PARTS LIST		Liste besteht LIST CONSISTS.
06										Benennung DESCRIPTION
05									Blatt SHEETS	
04										
03	7088.114	25.8.87	ADT							
02	7088.66	27.5.87	No.	1986	Tag DATE	Name NAME	Bezeichnung Schlumberger PART NO		Blatt Nr. SHEET NO	
01	7088.44	1.4.87	Di	geschr.	10.9.86	Dietrich	361 457 Sa		5	
	6088.18	10.9.86	Di	beerb.			217 031 S			
Ausgabe ISSUE	Änd.-Messg. Nr. MODIFIC. NO.	Tag DATE	Name NAME	gepr.			Hierzu Schaltplan SEE CIRCUIT DIAGRAM			
							Gerät: 4031			

Diese Zeichnung ist unser Eigentum. Vervielfältigung, unbefugte Verwertung, Mitteilung an andere ist strafbar und schadenersatzpflichtig.

The electronic attenuator consists of the individual attenuators B2/20 dB, B3/20 dB, B4/30 dB, B5/30 dB with the associated lifting magnets and the electronic drive plus a switch selector.

The coils are on +5 V on one terminal.

The switching transistors take the other terminal of the relay coil to ground (holding state).

For energizing the second terminal of the coil is not switched to ground but to the plate of the electrolytic capacitor charged to -15 V.

The current pulse is the result of  $V_0$ ,  $R_{coil}$ ,  $R_{CETswitch}$  and  $R_{Vcharge}$ . Latch and PIA form the digital interface.

**Driving:**

The data lines 10, 11, 12, 13 switch the four attenuator magnets to hold ( $\hat{=}$  High) or release ( $\hat{=}$  Low).

Data line 14 actuates the switch selector.

If magnets attract from the idle state, data line 9 is also to be switched High for 20 ms (= starter, Clock  $\hat{=}$  control line 8)

- 6088.24

Ref.No. 226 031 F Type 4031	Sub Attenuator Unit	Date <i>22.8.86</i>
		Sheet 1/1

D

C

B

A

To MOTHER-BOARD  
361 136 S

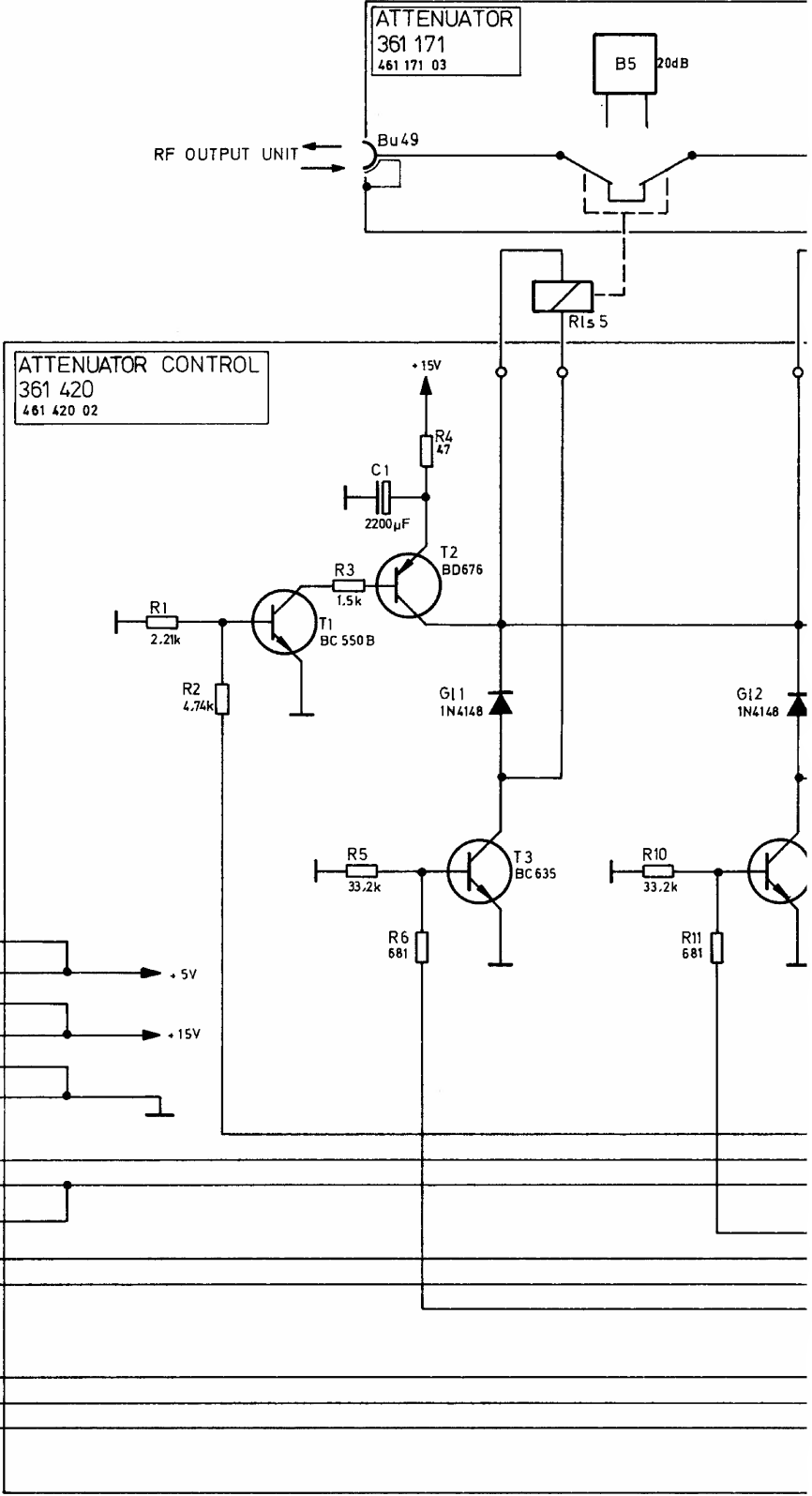
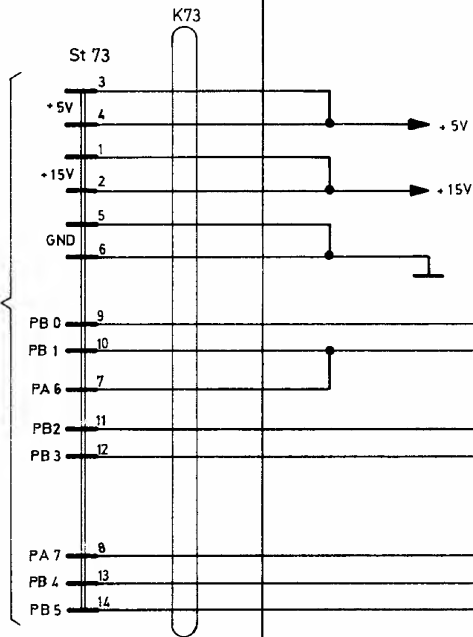

sw BLACK	bl BLUE				norm.		
br BROWN	vi VIOLET				gepr.		<i>ka</i>
rt RED	gr GREY				bearb.	25.7.	<i>sz.</i>
rs ROSE	ws WHITE						
ge YELLOW	tr TRANSPARENT						
gn GREEN							
		- 6088 31	15.10.96	Staff			
Ausg.	A-Mittlg.	Datum	Name		Datum	Name	
ISS.	MODIF.	DATE	NAME		DATE	NAME	

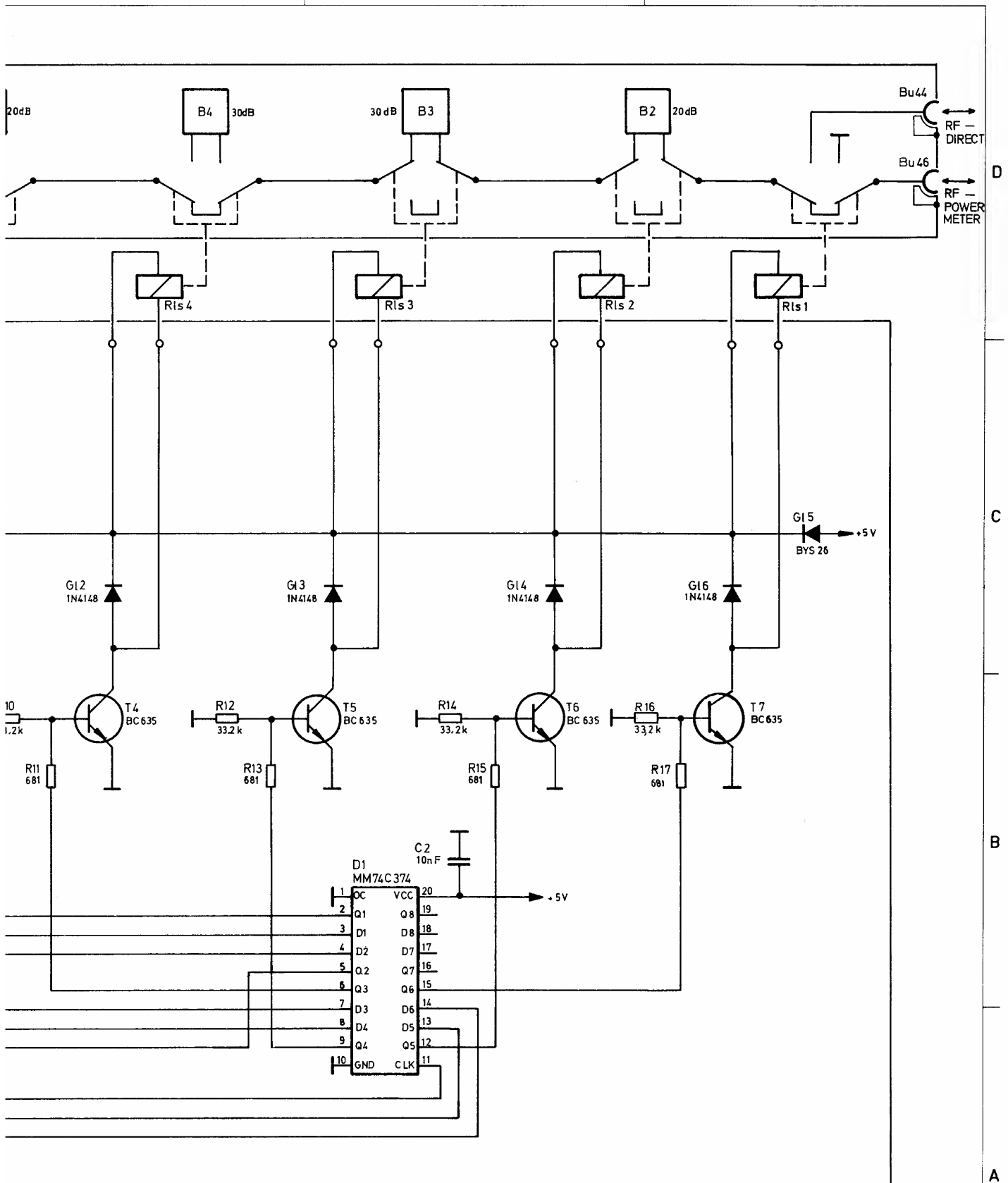

m.		 Schlumberger Meßgeräte GmbH Ingolstädter Straße 67 a 8000 München 46	<h1>RF-ATTENUATOR</h1>	226 031S
irb.	25.7.7.			Gerät: 4031
	Datum	Name		
	DATE	NAME		

re ist strafbar und schadenersatzpflichtig.

1. Leiterplatte gereinigt
2. Dämpfungschips mit Leitkleber 761 016 auf Leiterplatte geklebt(hierzu 099 068V) und unter leichtem Druck 1 Stunde bei 120°C ausgehärtet
3. Ultraschall gereinigt
4. Staubfrei verpackt

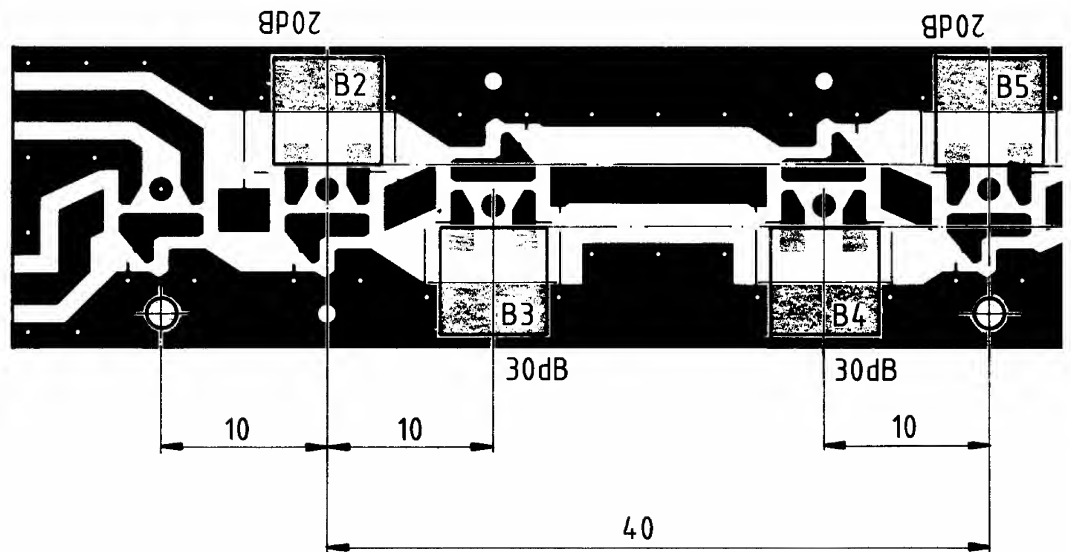

 = Kon

10				Richtteil
09				
08				
07				Werkstoff
06				
05				
04				
03				Oberfläche
02	8088.30	24.1.88	Reind.	
01	6088.31	15.10.86	Steff	
Ausgabe	Andg. Mittlg.	Datum	Name	

verw. in: 226 031

Gerät : 4031

Druckung ≅ 226 031S/361 171Sa

51 016 auf  
068V) und  
bei 120°C ausgehärtet

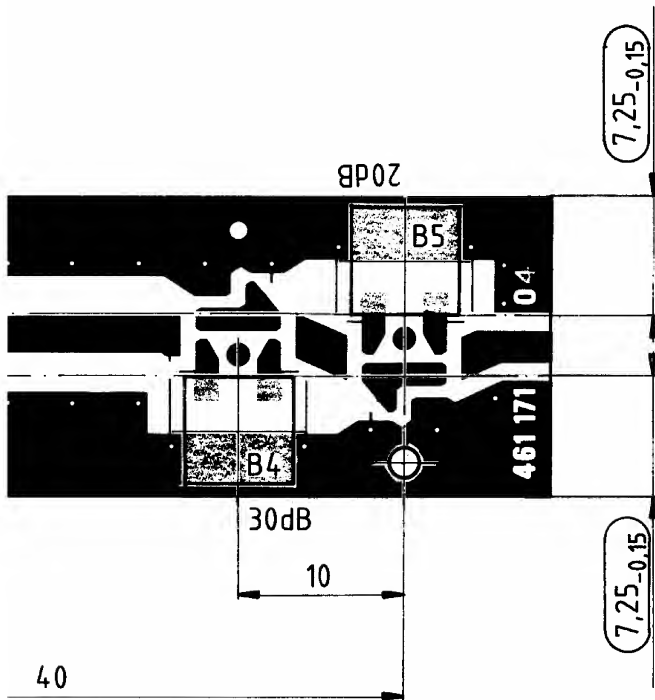

= Kontrollmaß

10				Rohteil	Freimaß Toleranzen	Maßstab:	Schlumberger Meßgeräte GmbH Ingolstädter Straße 67 a 8000 München 46
09							
08				Oberfläche	1986	Datum	Name
07							
06				Ausgabe	Andg.	Mitgl.	Datum
05							
04				03	6088.31	15.10.86	Staff
03							

Diese Zeichnung ist unser Eigentum. Vervielfältigung, unbefugte Verwertung, Mitteilung an andere ist strafbar und schadenersatzpflichtig.



428 268(4x)

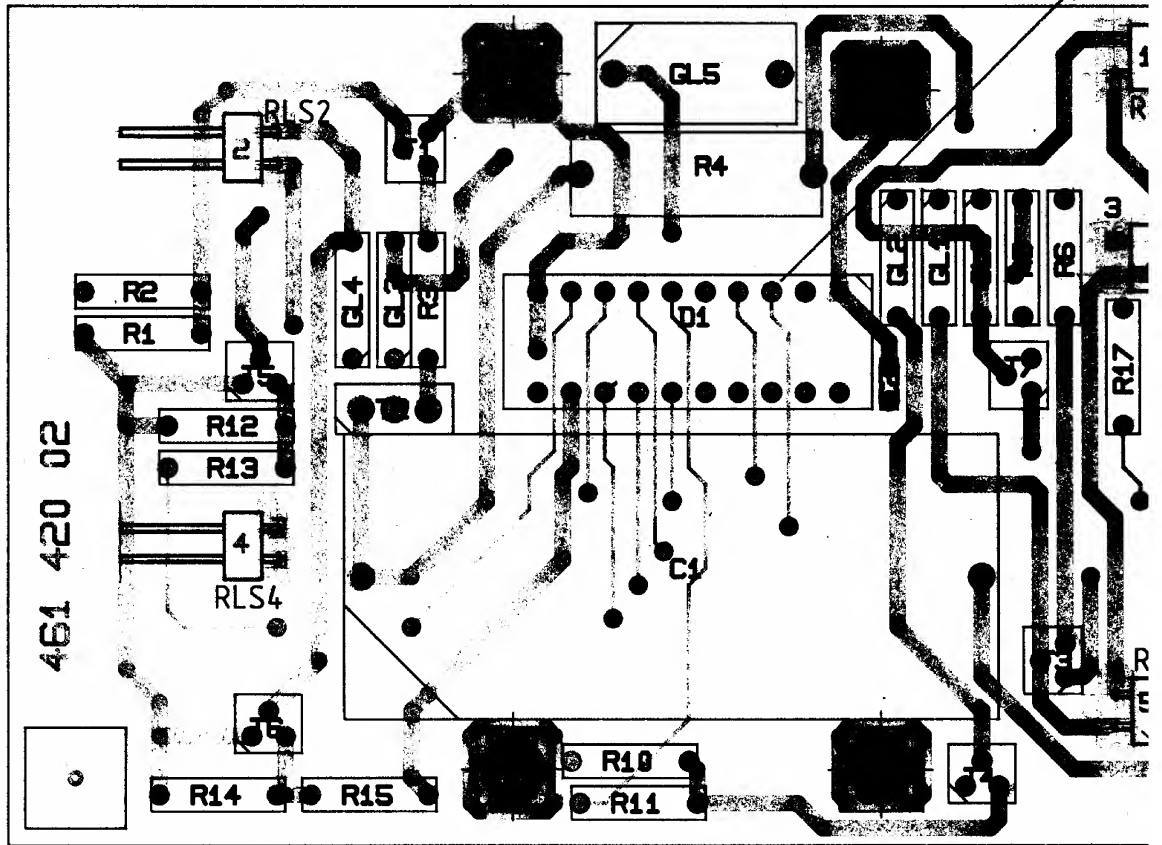

10				R
09				
08				
07				
06				W
05				
04				
03				
02				Q
01	6088.31	15.10.86	Styl	
Ausgabe	Ändg-Mittig	Datum	Name	

verw. in: 226 031

Gerät : 4031

tionierung  $\cong$  226 031S/361 420Sa

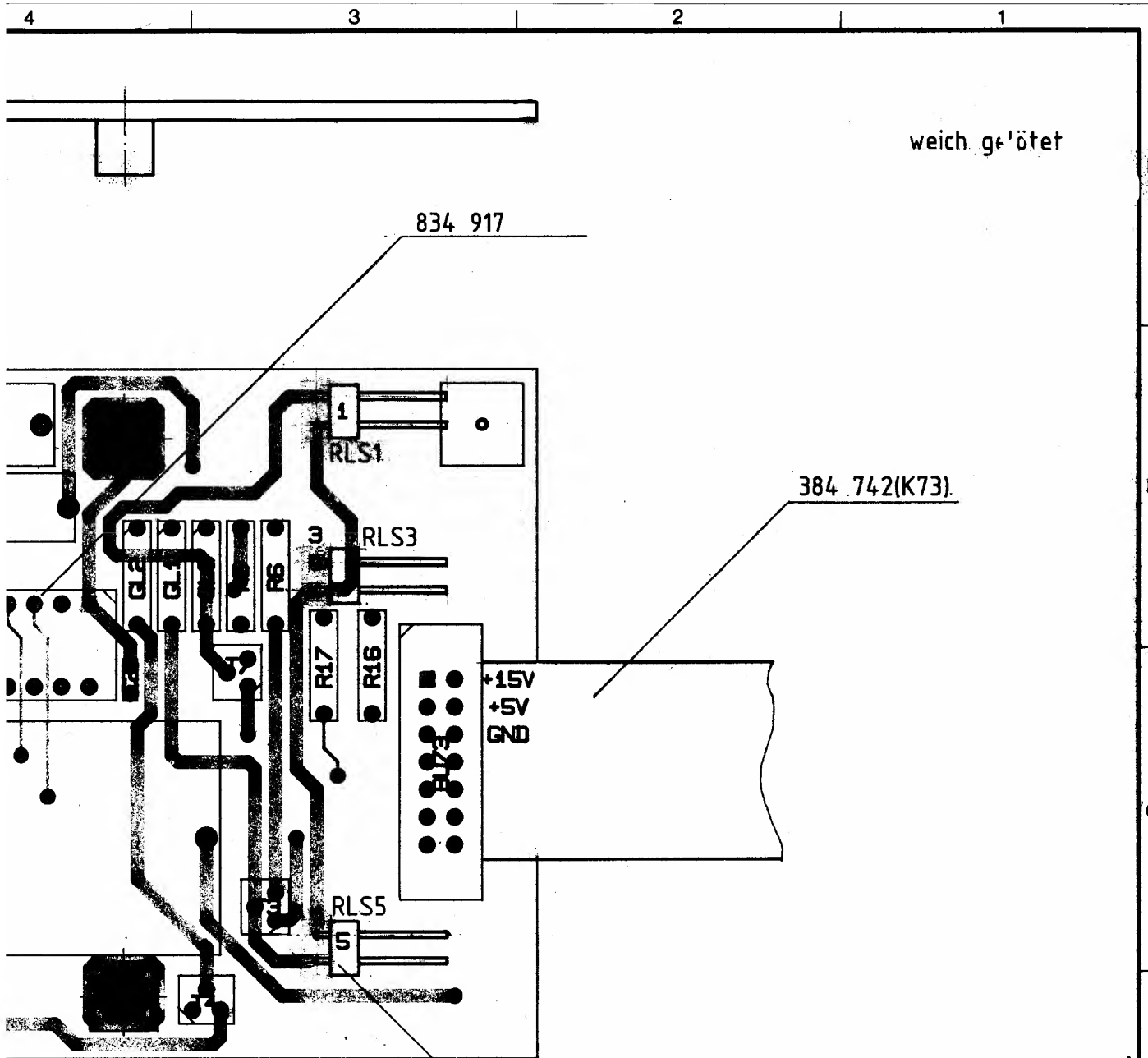

weich gelötet

834 917

384 742(K73)

884 739(5x)

○ = Kontrollmaß

10				Rohteil:	Freimaßtoleranzen:	Maßstab:	Schlumberger Meßgeräte GmbH Ingolstädter Straße 67 a 8000 München 46
09						2:1	
08				Werkstoff:			Bestückte Leiterplatte Typ: ATTENUATOR CONTROL
07							
06							361 420
05							
04							361 420
03							
02				Oberfläche:	1984	Datum	Name
01	6088.31	15.10.84	Steffl		gez.	15.10.	Steffler
Ausgabe	Ändg.-Mittig	Datum	Name		bearb.		
					gepr.		

1	2	3	4	5	6	7	8	
Pos. REF NO	Wert VALUE	Bezeichnung Schlumberger PART. NO.	Hersteller MANUFACT	Pos. REF. NO.	Wert VALUE	Bezeichnung Schlumberger PART. NO.	Hersteller MANUFACT	
1	Bestückte Leiterplatte	361 171						
	hierzu	361 171 Sa						
1	Bestückte Leiterplatte	361 420						
	hierzu	361 420 Sa						
Bu 44	22 SMA - 50 - 0 - 3	886 295	SUHN					
Bu 46	22 SMA - 50 - 0 - 3	886 295	SUHN					
Bu 49	22 MCX - 50 - 0 - 2	886 185	SUHN					
R1s 1								
R1s 2								
R1s 3		Hubmagnet	300 650	SCHL				
R1s 4								
R1s 5								

07				Schlumberger Meßgeräte GmbH Ingolstädter Straße 67 a 8000 München 46			Schaltteilliste EL. PARTS LIST		Liste besteht LIST CONSISTS aus OF 1 Blatt SHEETS		
06			Benennung DESCRIPTION							RF -ATTENUATOR	
05							Bezeichnung Schlumberger PART. NO.		226 031 Sa		Blatt Nr. SHEET NO. 1
04							Hierzu Schaltplan SEE CIRCUIT DIAGRAM		226 031 S		
03				Tag DATE		Name NAME					
02				1986							
01	6088.31	16.10.86	Staff	1986							
-	6088.10	20.8.86	Ke	geschr.	23.4.86	Coenen					
Ausgabe ISSUE	And.-Mittig Nr. MODIFIC. NO	Tag DATE	Name NAME	bearb. gepr.		<i>Ke</i>	Gerät: 4031				

Diese Zeichnung ist unser Eigentum. Vervielfältigung, unbefugte Verwertung, Mitteilung an andere ist strafbar und schadenersatzpflichtig.



1	2	3	4	5	6	7	8
Pos. REF. NO	Wert VALUE	Bezeichnung Schlumberger PART NO.	Hersteller MANUFACT	Pos. REF. NO	Wert VALUE	Bezeichnung Schlumberger PART NO	Hersteller MANUFACT
				R 3	1,50 kΩ ± 1 %	802 039	RÖD
				R 4	47 Ω ± 10 %	805 123	DRAL
				R 5	33,2 kΩ ± 1 %	802 055	RÖD
Bu 73	in K 73			R 6	681 Ω ± 1 %	802 035	RÖD
C 1	2200 µF +50% -10% 25V-	814 166	SIE				
C 2	10 nF ±10% 50V-	813 115	STET	R 10	33,2 kΩ ± 1 %	802 055	RÖD
				R 11	681 Ω ± 1 %	802 035	RÖD
				R 12	33,2 kΩ ± 1 %	802 055	RÖD
				R 13	681 Ω ± 1 %	802 035	RÖD
D 1	MM 74 C 374	834 330	NAT	R 14	33,2 kΩ ± 1 %	802 055	RÖD
				R 15	681 Ω ± 1 %	802 035	RÖD
				R 16	33,2 kΩ ± 1 %	802 055	RÖD
G1 1	1 N 4148	830 240	ITT	R 17	681 Ω ± 1 %	802 035	RÖD
G1 2	1 N 4148	830 240	ITT				
G1 3	1 N 4148	830 240	ITT	T 1	BC 550 B	832 127	SIE
G1 4	1 N 4148	830 240	ITT	T 2	BD 676	832 309	SIE
G1 5	BYS 26	830 027	ITT	T 3	BC 635	832 129	SIE
G1 6	1 N 4148	830 240	ITT	T 4	BC 635	832 129	SIE
				T 5	BC 635	832 129	SIE
K 73	Kabelbaum CABLE HARNESS	384 742	SCHL	T 6	BC 635	832 129	SIE
				T 7	BC 635	832 129	SIE
R 1	2,21 kΩ ± 1 %	802 041	RÖD				
R2	4,75 kΩ ± 1 %	802 045	RÖD				

07				Schlumberger Meßgeräte GmbH Ingolstädter Straße 67 a 8000 München 46			Schaltteilliste EL. PARTS LIST		Liste besteht LIST CONSISTS aus OF 1 Blatt SHEETS Blatt Nr SHEET NO 1		
06			Benennung DESCRIPTION							Bestückte Leiterplatte Typ : ATTENUATOR CONTROL	
05			1986				Tag DATE	Name NAME		Bezeichnung Schlumberger PART NO	361 420 Sa
04			geschr				22.4.86	Coenen		Hierzu Schaltplan SEE CIRCUIT DIAGRAM	226 031 S
03				bearb.		Gerät:	4031				
02											
01	6088.31	15.10.86	Staff								
	6088.10	20.8.86	Ca								
Aus- gabe ISSUE	Änd.-Mitgl. Nr MODIFIC NO.	Tag DATE	Name NAME	gbr.							

Diese Zeichnung ist unser Eigentum. Vervielfältigung, unbefugte Verwertung, Mitteilung an andere ist strafbar und schadenersatzpflichtig.